

950MD (Mill-Duty)



Linear Displacement  
Transducers

## Installation Manual

ALL STAINLESS STEEL HOUSING PROTECTS LINEAR  
DISPLACEMENT TRANSDUCERS FROM HEAT AND  
ENVIRONMENTAL DANGERS

**OPTIONS:**

STROKES FROM 1" TO 240"  
AIR COOLING PORTS  
VORTEX AIR COOLING  
WATER COOLED HEADS  
2 CONNECTION POINTS

OFFERS LATERAL AND HORIZONTAL MOVEMENT  
TO COMPENSATE FOR MACHINE SLOP



**Protection & Mounting Simplicity for  
Linear Displacement Transducers**

# 950MD Mill-Duty Housing

## Series 950MD Housing

The series 950 Mill-Duty Housing (950MD) was designed for applications where mounting a stand-alone rod style linear displacement transducer (LDT) is prohibitive.

Potential physical damage, environmental conditions or mounting limitations are all elements that are involved in specifying a linear position feedback system that will perform flawlessly for many years to come. The 950MD housing has been designed to eliminate all of the above problems by protecting the LDT from physical and environmental damage such as temperature, corrosives, shock & vibration, or dust and debris. Additionally, the 950MD offers a simple two point mounting scheme that can compensate for lateral and/or horizontal movement of the machine while in operation. Mounting bolts are provided for both the trunnion mount and rod ends in either standard steel or optional Stainless Steel when specified.

The 950MD housing is also perfect for retrofitting existing cylinders with an LDT providing a continuous position feedback signal. The 950MD allows for a convenient way to mount the 950MD and internal LDT parallel to the cylinder. This eliminates the need to tear down and gun drill the cylinder to accommodate an LDT simply for providing position feedback that had not previously been available.

The housing may also be of benefit in this same configuration when you have an existing cylinder in operation that does not allow for an easy removal of the LDT. Old machines and even some existing machines or newly designed machines did not take into consideration the need for continuous position feedback. Certain machines may require that the entire cylinder be removed in order to replace the LDT.

The actuator contains a 1/2" spherical rod end with approximately 1" of adjustment (length). This spherical rod end allows mechanical movement in a horizontal and/or vertical motion to compensate for any mechanical slop or misalignment between the housing and machine. A rear trunnion mount is provided for mounting either directly in front of the head assembly or on the rear of the head. An optional 3/4" spherical rod end can be supplied on the rear of the unit (see drawing for details).

The back cap is supplied with threaded and plugged holes that allow for field installation of the 3/4" diameter trunnion mount bracket to the back cap. The trunnion mount bracket is positioned at the point where the head and barrel connect. A simple exchange of hardware is all that is necessary to move the trunnion mount bracket to the back cap and plug the no longer required bracket mounting holes. When ordering the 3/4" rear rod end



option, the trunnion mount bracket is not supplied since it would not be required.

The actuator rod is supported by two bearings within the guide tube. The front piston bearing contains a wiper assembly to keep contaminants from entering the guide tube. The rear, or movable, bearing assembly is manufactured from Rulon<sup>®</sup>. This high-temperature polymer material provides low wear and smooth operation.

The transducer magnet is mounted within the rear bearing assembly. The magnet is a 1" O.D. cylinder magnet (SD0410300). The magnet is positioned 2" from the end of the transducer hex when the actuator is fully retracted and 5" from the end of the transducer guide tube when the actuator is fully extended.

The 950MD is designed to incorporate an LDT which has a minimum 2" Null Zone and 5" Dead Band. The 951 LDT has a minimum 1.5" Null Zone and 2.25" Dead Band standard. When specifying a 951 LDT to be used in a Mill-Duty Housing, you must specify a 2" Null Zone and 5" Dead Band minimum to ensure mechanical and electrical compatibility.

# 950MD Mill-Duty Housing

Due to the fact that the standard Mill-Duty Housing has a mechanical stroke identical to the LDT active stroke, no physical over-stroke exists. If it is possible that the machine being coupled to can extend/retract beyond the stroke supplied, damage to the Mill-Duty Housing and possibly to the machine might occur. To compensate for this we call out fully retracted/fully extended over-stroke dimensions for the Mill-Duty Housing. These values are essentially the additional stroke length added to the Mill-Duty Housing. The reason they are called out separately is to alert the user that when entering these areas, they are out of the LDT active stroke area. If an extended over-stroke is specified, the LDT must be ordered with a Dead Band of  $5" + X$  (extended stroke value). If a retracted over-stroke is specified, the LDT must be specified with a Null value of  $2" + Y$  (retract over-stroke value).

The Mill-Duty Housing offers either a conduit entrance for hard wiring directly to the LDT within the head or an external connector and mate. The connector attaches to the LDT inside of the housing via a small pigtail connector within the head.

## Detailed Product Description and Materials of Construction

The 950MD consists of a 304 Stainless Steel body, barrel, piston, head and trunnion mount bracket.

The standard 1/2" diameter rod end with mounting bolt, the 3/4" diameter trunnion mounting bolt, and some of the optional MS connectors on the head are the only items that are not Stainless Steel on the standard assembly. This is also true of the optional 3/4" diameter front and rear rod ends with their mounting bolts. These rod ends and all mounting bolts can be ordered in Stainless Steel as an option. The 12mm Euro connector options C3 and C4 come standard in Stainless Steel. Consult the factory for further details.

The 950MD head assembly is removable to allow installation of a rod style LDT that will screw into the standard 3/4" - 16 x 1.00 mounting thread. An optional Metric thread of M18 X 1.5 can also be supplied upon request. The head contains a 1/2" NPT conduit port for wiring to the LDT or optionally an MS connector can be installed for the external wiring. Use of the MS connector will require that the LDT also have a connector on it in lieu of a potted cable.



This will allow for a quick connect at the LDT head internally and on the 950MD head externally. The 950MD head is sealed with O-rings and also contains two threaded air purge openings that are plugged but available for use to air cool the LDT head with filtered and regulated air. By removing the plugs and installing the proper size air fittings, you can cool the head electronics for high temperature applications. An optional Vortex air cooler may also be specified for the head and/or barrel or an optional water jacket for the LDT can be supplied. See the 950MD dimension drawings for further details.

## Consult Factory if installing 950IS into 950MD Housing

# 950MD

## Mill-Duty Housing

---

### Applications

The 950MD was originally designed for use in steel mill applications but has proven to be reliable in many applications where ruggedness, environmental protection and ease of mounting are required. Some of these applications include:

**Steel Mills** - Tundish car (Tundish height), turret height (Caster), hydraulic coil cars, torch cutoff machine (torch head monitoring), furnace tilt, electrode positioning, side guide positioning, ladle slide gate positioning, louver or roof position, etc.

**Foundries, Forging and Casting** – Linear transducers with 950MD housings have been used on sand mold compactors, furnace or oven doors and material transfer systems.

**Injection Molding and Die Casting** – Proven effective in monitoring/controlling the position of the clamp and/or shot cylinder. The two point connection of the 950MD housing allows for a simple retrofit by replacing limit switches with an LDT for position feedback over the entire range movement. Linear potentiometers can also be replaced, thus eliminating their problems with drift, temperature, and short life span.

**Hydraulic Servo Applications** - Ideal for installing parallel to hydraulic cylinders including new applications and retrofits. The major advantage to using the 950MD housing versus gun drilling the cylinder for an LDT is that the cylinder fluid flow is not compromised. If an LDT fails within a cylinder it cannot be removed without having to deal with the hydraulic fluid lines, pressure etc. Some cylinders may be difficult to remove once installed, thus inhibiting the removal of the LDT. The 950MD housing is typically mounted parallel to the cylinder, the same as a slave cylinder would be, so removal is greatly simplified under these conditions.

**Lock and Dam Sites** - Miter gate and Tainter valve position feedback systems have both benefited from the 950MD and LDT combination.

**Gate Position Feedback** - For hydro-electric plants, water control structures, water and wastewater treatment and managing, wicket gate position feedback for Turbine speed control.

### Optional Items

The standard Mill-Duty Housing includes the complete housing assembly with provisions to accept an LDT and all bolts, nuts and mounting hardware required for a complete installation. There are also several optional items available.

**Vortex Air Cooler** - The standard 950MD is equipped with air purge ports. In many cases, running clean shop air through the head is sufficient to cool the electronics. For severe temperature applications a Vortex Air Cooler may be desired. A Vortex Air Cooler accepts standard shop air (80 - 100 PSIG). The air is ejected through a generator in a Vortex spin chamber where the air stream revolves in a tube at up to 1,000,000 RPM. In simplest terms the inner stream gives off energy in the form of heat to the outer stream and the inner stream exits the opposite end as hot air. The Vortex Cooler is capable of generating air flows as cold as -40° F.

**Protective Boots** - To give added protection to the actuator rod, protective boots are available. These boots attach between the end of the Mill-Duty guide tube and the end of the actuator rod assembly. The boots are offered in neoprene coated nylon for most standard applications. They offer -60° F to 250° F operating range with resistance to water and oil. Also, silicone coated fiberglass offers high temperature resistance from -100° F to 550° F; Teflon-coated fiberglass offers -100° F to 500° F operating range with a high degree of corrosion resistance and optional stainless steel boots for rugged applications.

**Water-Cooled Head Assemblies** - In applications where extreme temperatures are present and air cooling is not appropriate, water-cooled head assemblies are available. Cooling jackets within the head assembly allow water to flow around the electronics.

**Front and Rear Mount Spherical Rod Ends** - In applications where two spherical rod ends are required, rear mount spherical rod ends are available. The 3/4" rear rod end attaches to a threaded bolt extending from the rear of the head. The 3/4" front rod end is threaded into the piston rod. An optional stainless steel version is available. Mounting bolts are supplied with both versions.

**Delrin Liner** - Used in longer horizontal applications, typically 60" or longer to prevent wear on the LDT's guide tube as the 950MD housing is stroked. The Delrin liner is installed inside of the 950MD barrel and prevents sag of the LDT's guide tube.

# 950MD Mill-Duty Housing

## PART NUMBERING

**950MD** — **12A** — **0B** — **0C** — **X** — **X**

**Active Stroke in Inches**  
Determine the "active" stroke to be measured followed by "A"

**Fully Retracted Over-Stroke in Inches**  
Insert length of retracted over-stroke in inches followed by "B". If no retract over-stroke is required, simply insert "0B"

**Fully Extended Over-Stroke in Inches**  
Insert length of extended over-stroke in inches followed by "C". If no extended over-stroke is required, simply insert "0C"

Connector	
X	Standard 1/2 inch NPT conduit fitting (It is suggested to order a quick disconnect connector on the LDT)
C	MS Style Connector and Mate on Side of Housing (for 950 LDT)
C2	Environmental MS connector and mate on side of housing (specify the Gemco LDT to be used within the body of the order; if the housing is being used with a competitive probe, please contact a Customer Service Representative at 800.635.0289.
C3	5 Pin, 12mm, Euro Connector on Side of Housing (for 952A or 953A w/connector option S only)
C4	6 Pin, 12mm, Euro Connector on Side of Housing (for 953D and 953SSI w/connector option S only)
C5A	10 Pin STD - to 953A 5 Pin Euro
C5D	10 Pin STD - to 953D 6 Pin Euro
NC	No Head Cover on the 950MD Housing
W	Special Head cover for LDT using water cooled jacket. Allows entry and exit of water lines. NOTE: This option does not support connector options. This option relies on the LDT connector option for field wiring.
CGA	Cord Grip Stainless Steel for Cable dia. .19" - .25"
CGB	Cord Grip Stainless Steel for Cable dia. .25" - .31"
CGC	Cord Grip Stainless Steel for Cable dia. .31" - .38"
CGP	Cord Grip PVDF for Cable dia. .1" - .3"

Connector	
X	None
V	Vortex air cooler
B1	Protective boot – neoprene coated nylon (-60°F to +250°F)
B2	Protective boot – silicone coated fiberglass (-100°F to +550°F)
B3	Protective boot – Teflon coated fiberglass (-100°F to 500 °F)
R	Rear mount spherical rod end 3/4"
F	Front mount spherical rod end 3/4"
RS	Stainless steel rear mount spherical rod end 3/4" with 304 stainless steel mounting bolt
FS	Stainless steel front mount spherical rod end 3/4" with 304 stainless steel mounting bolt
L	Delrin liner for extended life cycle on longer horizontal applications (used to protect the LDT rod assembly)
SB	304 stainless steel boot
A	Barrel Air Purge

NOTE: Consult Factory for Custom Configurations.

- Note 1: Guide tube support brackets are supplied as standard for strokes of 72" or greater.  
 Note 2: Special high temperature, abrasion resistant and oil resistant cables are available. Consult your Customer Service Representative.

950MD Compatibility Guide	
940	Yes
950IS	Consult Factory
951	Yes (Must be ordered w/2" Null Zone & 5" Dead Band)
952	Yes (Must be ordered w/2" Null Zone & 5" Dead Band)
953	Yes (Must be ordered w/2" Null Zone & 5" Dead Band)
955	See 956 Section
7330	Consult Factory

951, 952 and 953 LDT Cable Assemblies	
Item	Part Number
Cable Assembly with Mate for Option "C2" Connector Style, 6 Feet	SD0439700L6
5 Pin, Straight, Stainless Steel Cable Assembly with Mate for Option "C3" Connector Style, 6 Feet	949013L6
6 Pin, Straight, Stainless Steel Cable Assembly with Mate for Option "C4" Connector Style, 6 Feet	949031L6

Accessories	
Item	Part Number
Vortex Cooler	04578009
Muffler for Cooler	04578010
Piston & Magnet Subassembly	SD0452400
Replacement 1/2" Spherical Rod End	04570140
Guide Tube Support Bracket (See note 1)	C0903400
Replacement (Male Connector) for Option "C2" Connector	04521407
Female Mating Connector for Option "C2" Connector	04521372
Replacement (Male Connector) for Option "C3" Connector	04521568

950 LDT Cable Assemblies	
Item	Part Number
Cable Assembly with Mate for Option "C" Connector Style, 6 Feet, (For 950-CP)	SD0436700L6
Cable Assembly with Mate for Option "C" Connector Style, 6 Feet, (For 950A/950TP)	SD0436000L6

# 950MD Mill-Duty Housing

## Standard 950MD

**NOTES: UNLESS OTHERWISE SPECIFIED**

1. DIMENSIONS IN BRACKETS [mm] ARE IN MILLIMETERS.
2. FOR LDT OUTPUT SIGNAL CHARACTERISTICS IN THE OVER-STRIKE ZONES, SEE APPROPRIATE CATALOG SECTION.

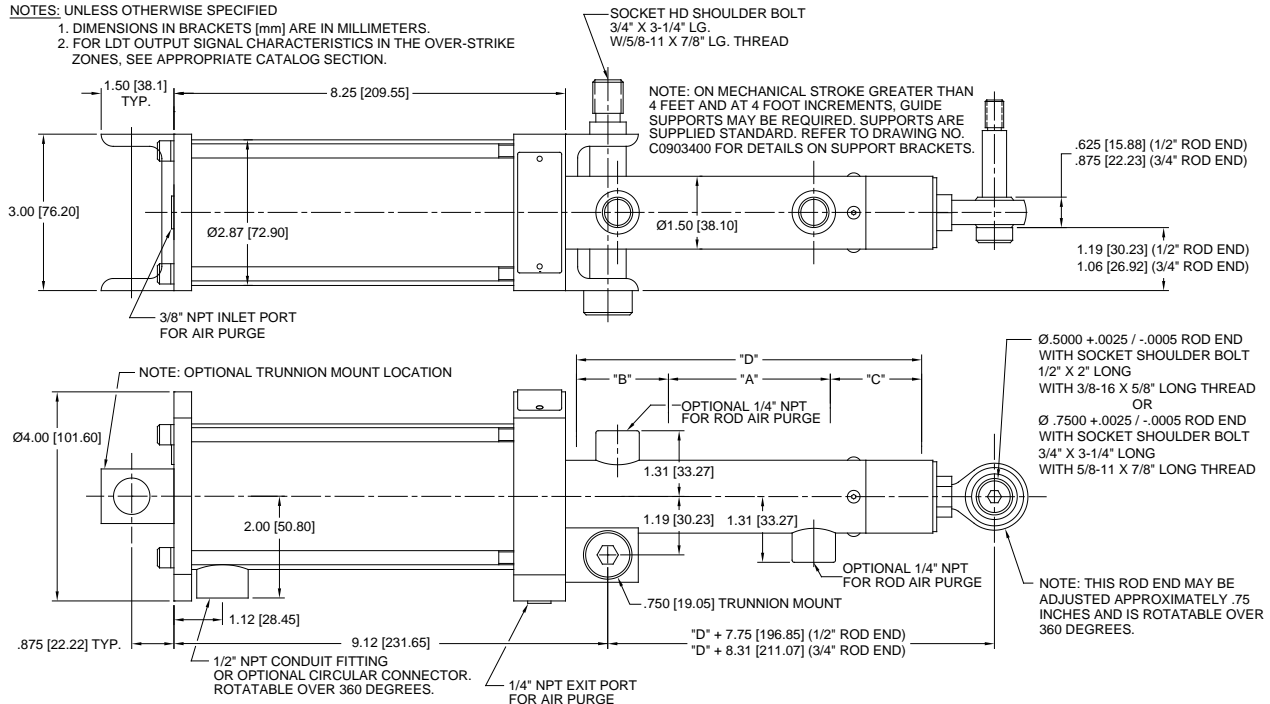

- "A" - ELECTRICAL STROKE = \_\_\_ IN.
- "B" - RETRACTED OVER-STROKE = \_\_\_ IN.  
STANDARD = 0 IN.
- "C" - EXTENDED OVER-STROKE = \_\_\_ IN.  
STANDARD = 0 IN.
- "D" - TOTAL MECHANICAL STROKE = \_\_\_ IN.  
SUMMATION OF A, B, & C.

## Mill-Duty with Rear Mount Spherical Rod End

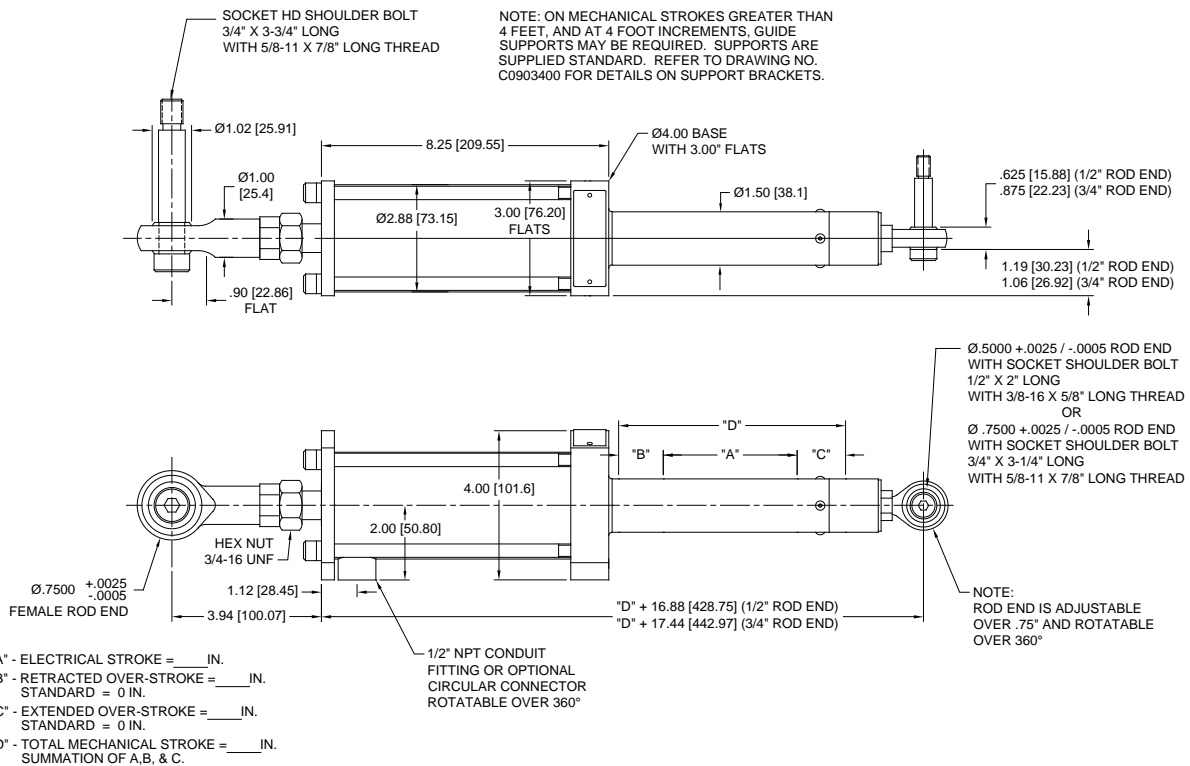

- "A" - ELECTRICAL STROKE = \_\_\_ IN.
- "B" - RETRACTED OVER-STROKE = \_\_\_ IN.  
STANDARD = 0 IN.
- "C" - EXTENDED OVER-STROKE = \_\_\_ IN.  
STANDARD = 0 IN.
- "D" - TOTAL MECHANICAL STROKE = \_\_\_ IN.  
SUMMATION OF A, B, & C.

# 950MD Mill-Duty Housing

## Quik-Stik Mill-Duty Housing

### MOUNTING CONSIDERATIONS FOR HYDRAULIC CYLINDERS

The following information is intended to aid the user in mounting the Series 950MD to a hydraulic cylinder. The details shown here are only guidelines; because so many possible applications and configurations exist, it is up to the design engineer to determine the exact mounting. Refer to drawing on page 7 for use with references below.

**A) Hydraulic Cylinder Mounting Block** - In many instances it is not feasible to drill and tap the end cap on cylinders. It is recommended that a tap block be welded to the cylinder end cap. The block should be as parallel to the front mounting surface as possible.

**B) Trunnion Mount Socket Head Shoulder Screw** - A 3/4" x 3-1/4" shoulder bolt is supplied for trunnion mounting. The shoulder extends approximately 1/4" from the trunnion mount. This extension allows for rotational movement of the trunnion over the shoulder bolt. If a longer distance between the trunnion mount and the interface device is required, a longer shoulder bolt should be used. A pipe with an I.D. slightly larger than the shoulder bolt O.D should be placed over the shoulder bolt between the trunnion mount and the interface device. Leave approximately 1/4" play between the trunnion mount and interface device to accommodate rotational movement.

**C) Barrel Support Bracket** - Each Mill-Duty housing with a stroke of 6 feet or greater is supplied with barrel support brackets (every 6' Increment). The support brackets operate to keep the barrel from sagging under its own weight. The bracket is configured to support the barrel without greatly restricting side-to-side and up/down movement. The barrel support bracket(s) should be mounted so that the barrel support hole is centered over the barrel. Mounting configurations that put a force load on the tube may affect the operation and longevity of the unit.

**D) Front Spherical Rod End** - A 1/2" x 2" shoulder bolt is provided to interface with the spherical rod end. The rear trunnion allows for some up/down movement of the Mill-Duty housing while the spherical rod end allows both up/down and side-to-side movement to accommodate for misalignment. The shoulder bolt attaches to the movable portion of the machine that the cylinder is driving. A pipe with an I.D. clearance for a 1/2" shoulder bolt should be placed between the spherical rod end and the interface surface, allowing 1/4" clearance for proper movement.

**E) Rear Mount Trunnion (Spherical Rod End)** – In cases where the trunnion is to be mounted on the rear of the Mill-Duty housing, most notably with clevis mount cylinders, the following points should be noted; **1)** A clevis pin modification needs to be made to allow the rear shoulder bolt to mount to it. This can be as simple as drilling/tapping larger pins or welding a nut to the end of a pin. **2)** For best results the trunnion shoulder bolt should be directly centered with the clevis pin. **3)** With a rear mount trunnion the Mill-Duty housing sits farther forward on the cylinder, thus potentially putting the active stroke of the Mill-Duty housing too far forward. Care should be taken when mounting to prevent this situation. An optional rear mount 3/4" spherical rod end is also available. See drawing for mounting considerations.

**F) Active Stroke/Mechanical Stroke** - The Mill-Duty housing has typically been supplied with a mechanical stroke that is the same as the electrical active stroke of the linear displacement transducer. It is possible to get an additional retract and/or extend over-stroke to accommodate cylinder over-stroke conditions. When mounting the Mill-Duty housing, make sure that there is sufficient clearance when the cylinder is fully retracted and sufficient stroke length on the Mill-Duty housing when the cylinder is fully extended. Otherwise, damage to the Mill-Duty housing and/or the machine could occur.

**G) A 1/2" Conduit Fitting** is supplied for wiring of the linear displacement transducer. If the Mill-Duty housing will be moving in/out or side-to-side during operation, hard conduit is not recommended. A short length of flexible conduit (approximately 2 feet) connected to a junction box is normally the best method of connection.

# 950MD Mill-Duty Housing

## CONCEPTUAL MOUNTING OF 950MD TO HYDRAULIC CYLINDERS

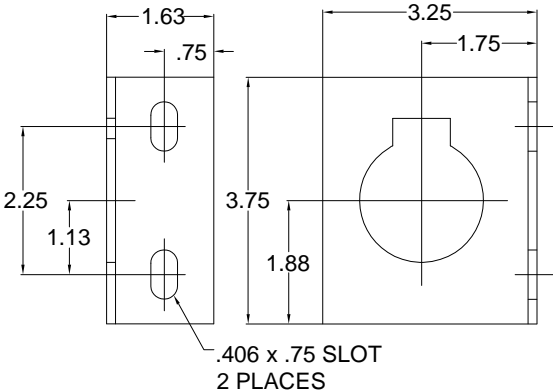
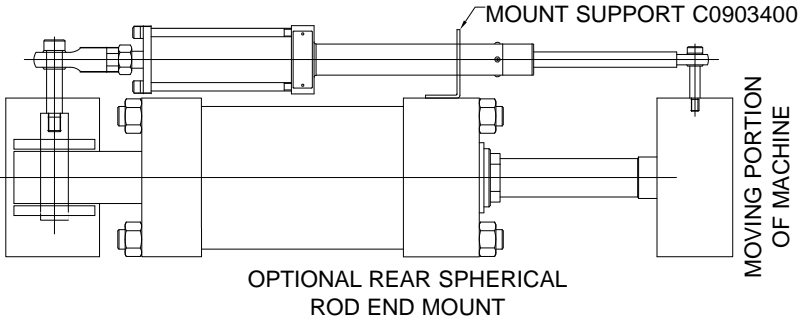
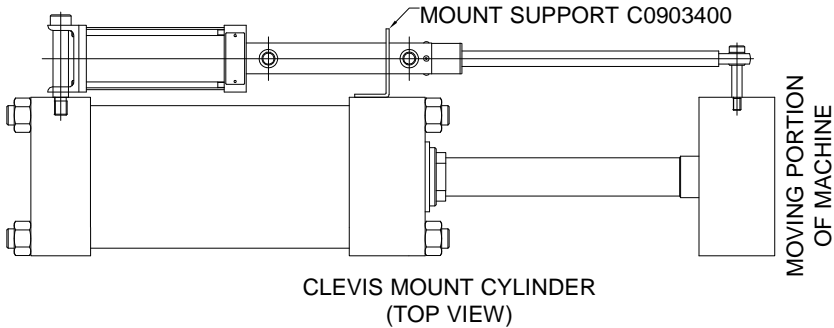
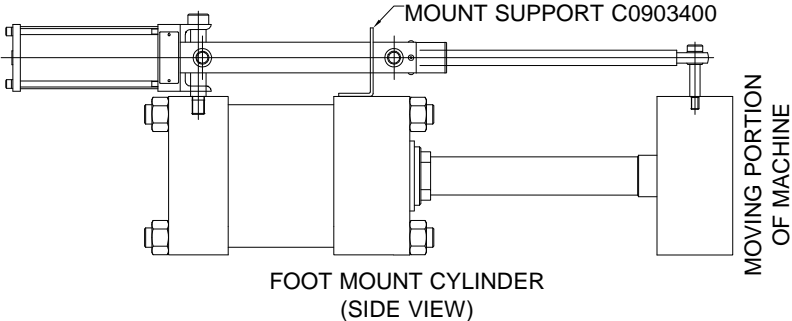

OPTIONAL MOUNTING SUPPORT  
PART NUMBER C0903400





# 950MD Mill-Duty Housing



## AMETEK APT Products



- GEMCO**
- LINEAR DISPLACEMENT TRANSDUCERS
- PLC INTERFACE PRODUCTS
- ROTARY POSITION PRODUCTS
- PROGRAMMABLE LIMIT SWITCHES
- EXTREME DUTY CABLE REEL PRODUCTS
- ROTARY LIMIT SWITCHES
- RESOLVERS
- MILL DUTY ENCLOSURES
- ULTRA HIGH SPEED PLS
- SAFETY PRODUCTS

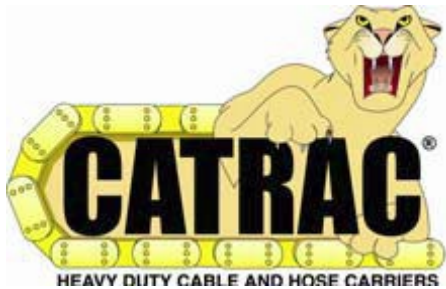

**Copyright 2013 by AMETEK AUTOMATION & PROCESS TECHNOLOGIES. All Rights Reserved. Made in the USA.**



1080 N. Crooks Road, Clawson, MI 48017  
 Phone: 248.435.0700 Toll Free: 800.635.0289  
 Fax: 248.435.8120 [www.AMETEKAPT.com](http://www.AMETEKAPT.com)

950MD.M4R  
1/15.Z352