



Ordering Guide For Linear Displacement Transducers



**ABSOLUTE PROCESS CONTROL
KNOW WHERE YOU ARE... REGARDLESS**

Gemco Magnetostrictive Technology Made Easy

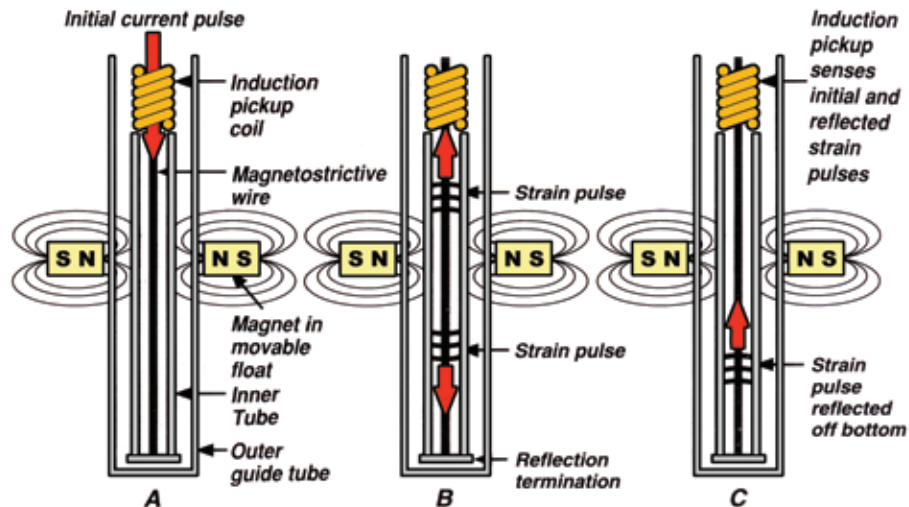

In a Gemco position sensor, a current pulse is sent down a magnetostrictive wire in a specially designed waveguide (Figure A). The interaction of this current pulse with the magnetic field created by the movable magnet assembly produces a torsional strain pulse on the wire, which travels at sonic speed along the wire (Figure B). The strain pulse traveling up the wire is sensed by a small induction pickup coil in the head assembly of the LDT. The position of the movable magnet is determined with high precision by measuring the time between the launching of the current pulse and the arrival of the torsional strain pulse. The result is highly accurate non-contact position sensing with absolutely no wear on the sensing element.

Hysteresis

The difference in indicated position when the same point is reached from two different directions.

Repeatability

The deviation in indicated position when a point along a stroke length is approached repeatedly from the same direction.

Magnetostriction

A magnetic field produces a small change in the physical dimensions of ferromagnetic materials on the order of several parts per million in carbon steel and, conversely, a physical deformation or strain (or stress which causes strain) produces a change of magnetization in the material.

Non-Linearity

The degree that the indicated position of the magnet at points along the stroke varies from the actual physical position. Non-linearity of an LDT is expressed in absolute error or as a percentage of the active stroke length.















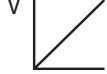







Resolution

Resolution is the smallest incremental change in position along the stroke length of the sensor that can be detected and indicated in an output. When using LDTs with analog output (i.e., voltage or current outputs), resolution is limited by the amount of power supply-induced output ripple and the sensitivity and/or design capabilities of the receiver electronics. Digital system resolution is defined by a specific value.

Recirculation

A method used to improve the resolution of a system using digital LDTs. The on time of the pulse width output is multiplied by a specific factor. This multiplication provides more counting time for the counter in the customer's electronics, thus improving the resolution.

Principles Of Operation

Series		Voltage	Current	Digital	Quadrature	Protocol
	950IS					
	950MD	Housing Only. This housing accepts all rod style LDTs.				
	952			D 	Q 	
	953			D 		Clock (+) Data (+) SSI 
	955			D 	Q 	
	956	Housing Only. This housing accepts all Series 955 BRIK style LDTs.				
	7230			D 		Modbus
	7330					

950IS

950MD

952

953

955









956

7230

7330

Misc.

Applications

Series	Harsh Environment "Mill-Duty"	Food and Beverage	Competitive Drop In Replacements	Hazardous Locations	Field Programmable	Multiple Magnet Capabilities
 950IS				✓		
 950MD	✓					
 952	✓				✓	952A Differential
	✓	✓			✓	952A Differential
	✓		✓		✓	Consult Factory
	✓				✓	Consult Factory
 953	✓	✓			✓	
	✓		✓		✓	
	✓				Consult Factory	✓
 955e		✓			✓	
					N/A	✓
			✓		✓	955A Differential
					✓	✓
 956		✓			Sensor Dependant	
 7230				✓		
 7330		✓		✓	✓	
		✓		✓	✓	

Principles Of Operation

Analog Version

The analog units are an industry standard and are available with voltage or current outputs. The output format, voltage or current, is hardware specified. The 952, 953 and 955 model LDTs have programmable voltage and current outputs.

The output's count direction, zero and span are all programmable. The 952, 953 and 955A and S units are programmable without any accessories or adaptors.

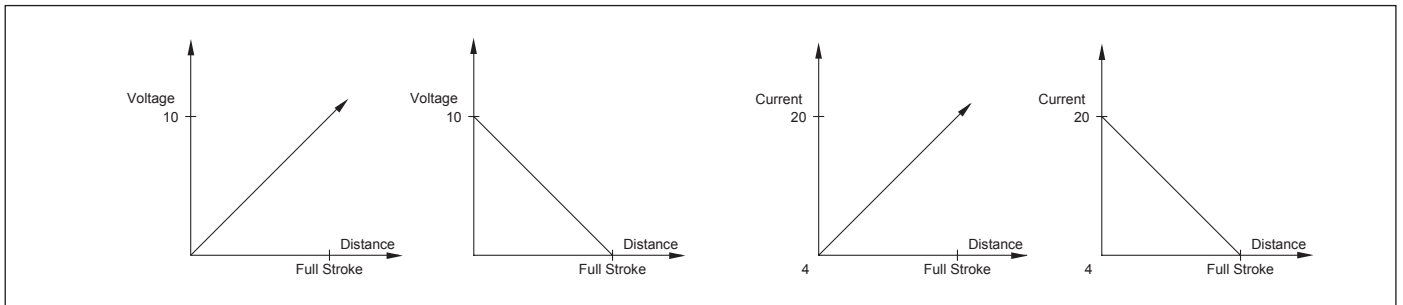

Control Pulse

The control pulse signal interface is a differential RS422 output. The maximum cable length for the differential digital LDT is 1,500 feet. To initiate a start pulse, an external device is used. This start pulse

should be 1.0 microsecond in duration. The time between the leading edge of the start pulse to the leading edge of the stop pulse is the proportional distance from the magnet to the hex head.

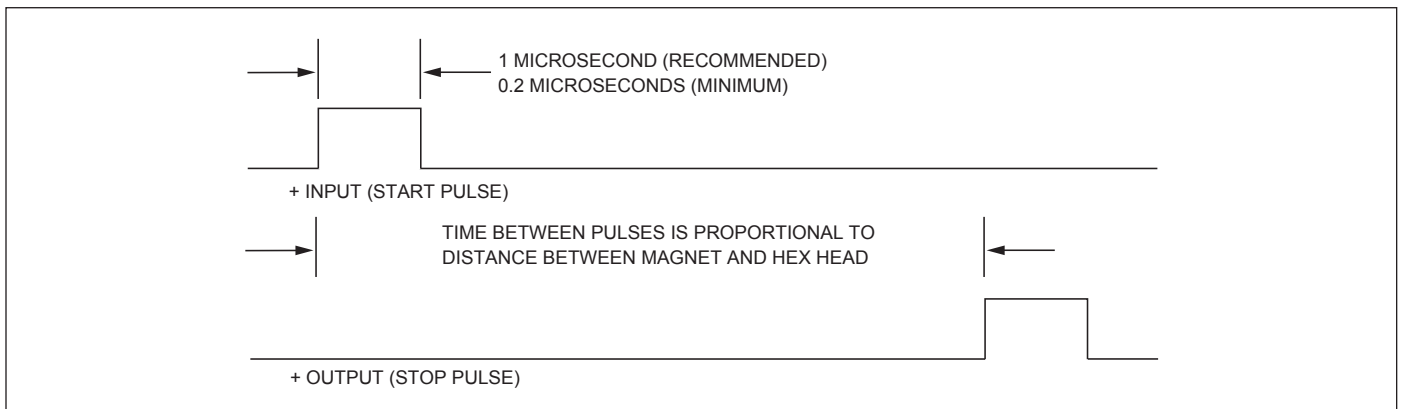

Output Types

Variable Pulse (PWM)

The variable pulse signal interface is a pulse width modulated signal (RS422). The maximum cable length for the differential LDT is 1,500 feet. The LDT can also be configured for external or internal interrogation. External interrogating is when an external device connected to the LDT generates a start pulse. This start pulse should be a minimum of 1.0 microsecond in duration. Within 50 nanoseconds after the leading edge of the start pulse has been received, the LDT will generate an output pulse. The duration of the output pulse is proportional to the distance from the magnet to the hex head. The order of these two pulses is illustrated below. The LDT can also generate internal interrogations. This LDT will continually output pulse width modulated signals. As with an LDT using an external interrogation, the duration of this output pulse is proportional to the distance from the magnet to the hex head.

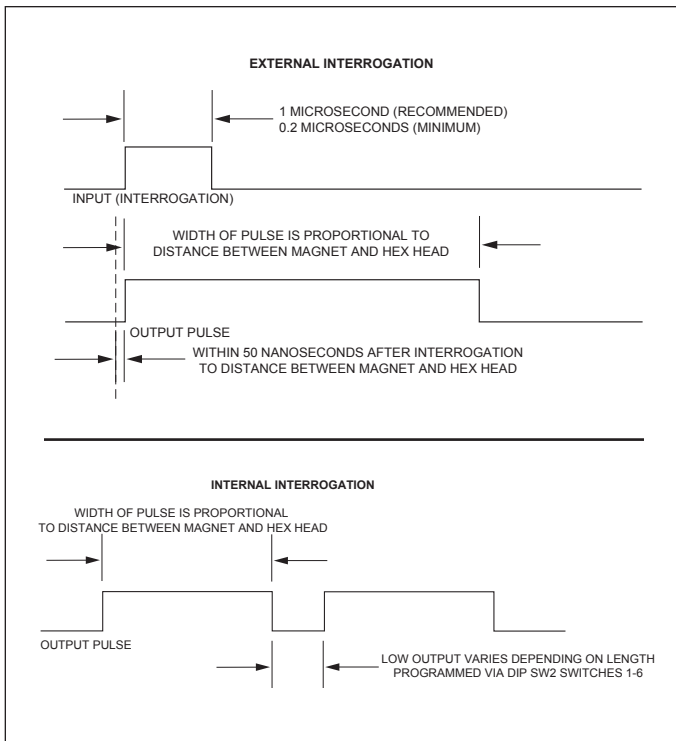

RS422 Start/Stop with Interrogation Start Sequence

The start/stop uses a 1 microsecond (minimum) external interrogation input to start a cycle. Based on the interrogation input, a pair of one microsecond return pulses are received and the time differential between the signals is proportional to the distance from the sensor head (hex) and magnet.

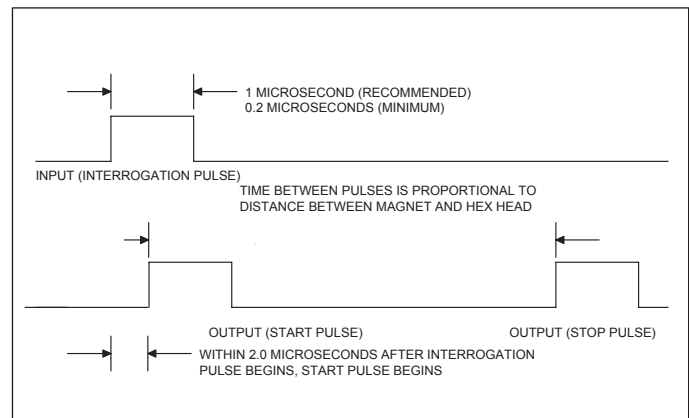

TTL Level Start/Stop Version

The TTL Level start/stop pulse system looks at a one microsecond TTL pulse (minimum) start pulse from an external source. The unit will then generate a TTL level stop pulse. The time span between the start/stop pulses is proportional to the distance from the sensor head (hex) to the magnet.

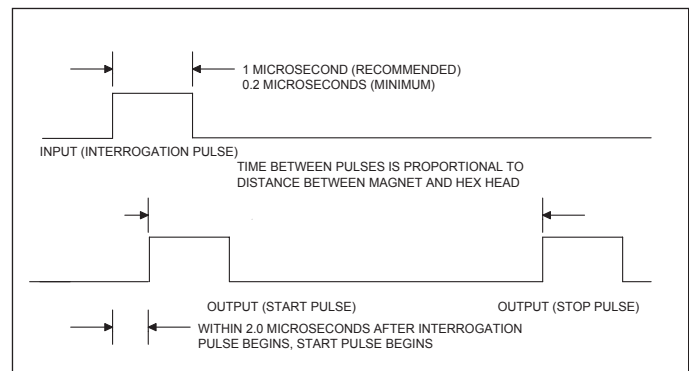

Output Types

Quadrature Output

A new method of interfacing magnetostrictive transducers offers an interface as common as analog with the speed and accuracy of a digital pulsed type signaling. The Gemco quadrature LDTs provide quadrature output directly from the transducer to the controller. The output from the transducer can be wired directly to any incremental encoder input or counter card, without the need for a special converter module or PLC interface card designed specifically for use with pulsed output magnetostrictive transducers. The quadrature output has the “A”, “B” and “Z” outputs. These outputs are “differential” (also known as balanced), which means that the connection for each output consists of two signal wires. These are typically described as the “plus” and “minus” signals. For example, the “A” channel consists of “A+” and “A-”. The same applies to the “B” and “Z” channels. For these (differential) outputs, the signal is measured with the reference to the other signal (i.e. the difference or differential). For example, if the “A+” single voltage is greater than the “A-” signal, channel “A” is a logic “0”. Again, this applies to the “B” and “Z” channels as well. Differential type signals are much less prone to interference caused by electrical noise or ground loops more often found in single ended signal connections. Line drivers are also available for driving single ended inputs that are not TTL compatible.

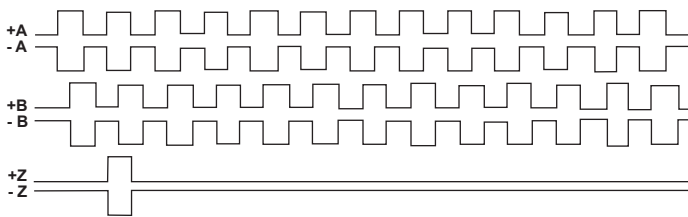

SSI (Synchronous Serial Interface)

Displacement value is encoded into a 24, 25 or 26 Bit format and transmitted at high speeds. Synchronization in a closed loop system is made easy. A clock pulse train from a controller is used to gate out sensor data: one bit of position data is transmitted to the controller per one clock pulse received by the sensor. The absolute position data is continually updated by the sensor and converted by the shift register into serial information. The sensors fulfill all requirements to the SSI standard for absolute encoders.

SSI Logic Diagram

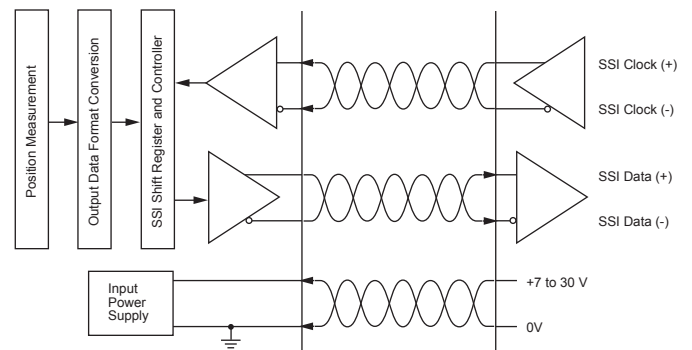

SSI Sensor Input

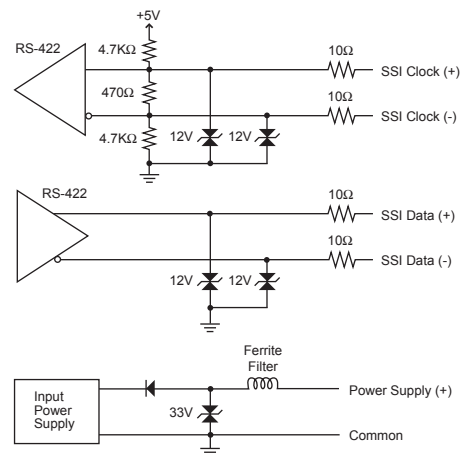

SSI Timing Diagram

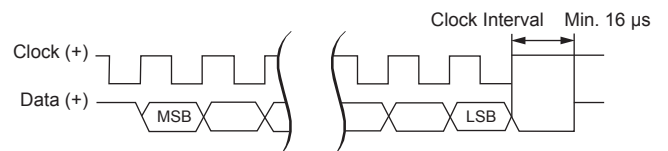



	952 BlueOx	952QD BlueOx Quadrature	953 VMAX	955LC BRIK	955 eBRIK	955S Smart BRIK
Supply Voltage	15-26 VDC	15-26 VDC	7-30 VDC	24 VDC	24 VDC	10-30 VDC
Analog Outputs						
4-20mA	Yes	No	Yes	Yes	Yes	Yes
0-10 VDC	Yes	No	Yes	Yes	Yes	Yes
Digital Outputs						
Stop/Start	Yes	No	Yes	No	No	No
Control Pulse	Yes	No	Yes	No	No	No
Pulse Width Modulated	Yes	No	Yes	No	No	No
Velocity	No	No	No	No	No	No
DeviceNet	Consult Factory	Consult Factory	Consult Factory	Consult Factory	Consult Factory	Consult Factory
SSI (Synchronous Serial Interface)	No	No	Yes	No	No	No
Modbus	No	No	No	No	No	No
Performance						
Position Accuracy (of full stroke)	0.05%	0.05%	0.01%	0.1%	0.03%	0.1%
Repeatability (of full stroke)	0.006%	0.001%	0.00006"	0.01%	0.001%	0.01%
Resolution	Internal Resolution 0.001"	0.001"	Analog - 0.00006" Digital - Controller Dependent SSI - Up to 1 Micron	Internal Resolution 0.014"	16-Bit	Internal Resolution 0.014"
Mechanical Considerations						
Lengths - 0.1" Increments	2-168"	2-168"	1-300"	6-180"	1-72"	4-180"
Null Zone	2"	2"	2" STD (1.5 optional)	3" STD (1.5 optional)	2.75"	3"
Dead Band	2.5"	2.5"	2.5" STD (2.25 optional)	1.5" STD (2.25 optional)	2.75"	1.5"
In Cylinder Mounting	Yes	Yes	Yes	On Cylinder Mounting	On Cylinder Mounting	On Cylinder Mounting
Enclosure Rating (IP)	IP67	IP67	IP68	IP67	IP67	IP67, IP68 Optional
Optional Mill Duty Housing	Yes	Yes	Yes	No	No	No
Options & Features						
Hand-Held Programmer	Yes	No	Yes	No	Yes	Yes
Ability to Program via PC	No	No	Consult Factory	No	No	No
Competitive Style Connector	Yes	No	Yes	No	No	No
High Shock & Vibration	Excellent	Excellent	Excellent	Good	Good	Good
Multiple Magnets	Yes	No	Yes	No	No	No
Universal Mounting Kit	Yes	Yes	Yes	Yes	Yes	Yes
Metric Threads & Dimensions	Yes	Yes	Yes	N/A	Yes	Yes
All Stainless Steel (Head & Potted Connector)	Yes	Yes	Yes	No	No	No
High Temp Cables	Yes	Yes	Yes	Yes	No	No
Applications						
Measurement	Yes	Yes	Yes	No	Yes	No
Heavy Industry, Lumber, Metal Stamping, etc.	Yes	Yes	Yes	Consult Factory	Consult Factory	Consult Factory
Positioning, Replacing Prox or Limit Switches	Yes	Yes	Yes	Yes	Yes	Yes
Cost	Mid-Range	Mid-Range	Mid-Range	Low	Low	Low



955A BRIK	955D BRIK	955DQ BRIK Quadrature	956 BLOK Housing Option	7230 Digital Stik	7330 Pro-Stik II
13.5-30 VDC	13.5-30 VDC	13.5-30 VDC	*	10-30 VDC	13.5-30 VDC
Yes	No	No	Yes	Optional	Yes
Yes	No	No	Yes	No	No
No	Yes	No	Yes	No	No
No	Yes	No	Yes	No	No
No	Controller Dependent	No	Controller Dependent	No	No
Consult Factory	Consult Factory	Consult Factory	Consult Factory	No	No
No	No	No	No	No	No
No	No	No	No	Yes	No
0.05%	0.05%	0.05%	*	0.01%	0.1%
0.006%	0.006%	0.006%	*	0.0001"	0.1%
Internal Resolution 0.001"	Controller Dependent	0.001"	*	0.0001"	Internal Resolution 0.014"
5-180"	5-180"	5-180"	4-36"	14-288"	8-288"
3"	3"	3"	*	9.25"	8"
2"	2"	2"	*	2.75"	2"
On Cylinder Mounting	On Cylinder Mounting	On Cylinder Mounting	*	No	No
IP67, IP68 Optional	IP67, IP68 Optional	IP67, IP68 Optional	*	IP66	IP68,3A Optional
No	No	No	No	No	No
Yes	Consult Factory	Consult Factory	*	No	No
Consult Factory	Consult Factory	Consult Factory	*	Yes	No
No	No	No	*	No	No
Good	Good	Good	*	Good	Good
No	Yes	No	*	Yes	No
Yes	Yes	Yes	*	No	No
Yes	Yes	Yes	*	No	N/A
No	No	No	*	No, Probe Only	Yes
No	No	No	*	Consult Factory	Consult Factory
Yes	Yes	Yes	Yes	Yes	Yes
Consult Factory	Consult Factory	Consult Factory	Yes	No	No
Yes	Yes	Yes	Yes	Yes	Yes
Mid-Range	Mid-Range	Low	Mid-Range	Mid-Range	Mid-Range

*The 956 BLOK is a housing option for the 955 BRIK. Refer to the 955 BRIK with the chosen output for complete sensor specifications.

The Gemco 950IS Inherently Safe LDT

The 950IS can be used in hazardous environments when connected to an approved safety barrier. The LDT is UL & CSA listed for Class I, Group C & D, Class II, Groups E, F, & G and Class III hazardous locations, when properly installed.

950IS

The term 'Inherently Safe' is used to describe electronic equipment that has the ability to be mounted directly in explosive atmospheres without chance of an explosion. The term 'Inherently Safe' pertains to a device's inability to produce an electrical spark of enough significance to cause ignition.

How does an Inherently Safe LDT work? A Gemco Transmitter (950-1446) is located in a "safe" or "non-explosive" area which accepts the system's supply voltage (115 VAC, 230 VAC, or 24 VDC) and generates the LDTs positional output signal in voltage or current. The transmitter also generates and accepts the LDT signals. These signals are driven through an approved inherently safe barrier assuring the safety of the system. Custom 950 Mill Duty enclosures are available for this LDT.

**Consult Factory if installing
950IS into 950MD Housing**

The 950IS is designed to work with Gemco style magnets. If installing in a hydraulic cylinder a Gemco style magnet must be used.



Specifications	
Input Voltage/ Current Draw	24 VDC @ 85mA max. 115 VAC 50/60 Hz @ 6 VA 230 VAC 50/60 Hz @ 6 VA
Output	0 to 10 VDC or 10 to 0 VDC 4 to 20mA or 20 to 4mA
Linearity	.01"
Repeatability	+/- 0.01% of Full Stroke
Operating Temperature	
Head Electronics	-10° to 180° F (-23° to 82° C)
Guide Tube	-40° to 185° F (-40° to 85° C)
Operating Pressure	3000 psi Operational, 8000 psi Spike
Span Length	1" to 300"
Null Zone	2"
Dead Band	5"
Connectors	2 Pin 12mm
Enclosure	IP65
Specifications are subject to change without notice.	

The Gemco 950IS Intrinsically Safe LDT

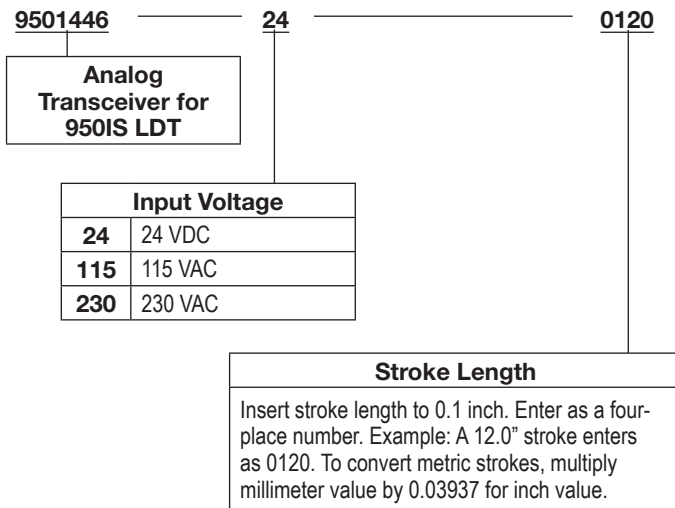
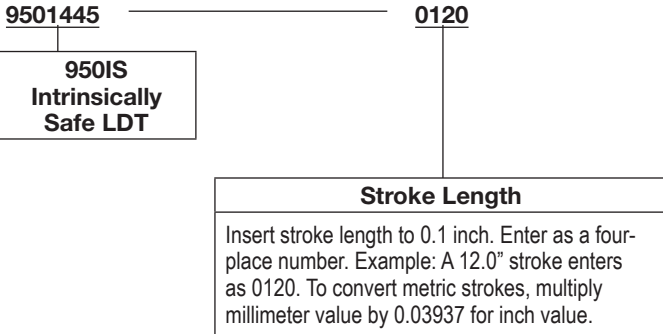

NOTE 1: A complete system consists of an LDT, a Gemco Magnet, a Transceiver and IS Barrier. IS Barrier and Panel Mount Bracket are ordered separately. IS Barrier P/N 04517039. Panel Mount Bracket for Barrier P/N 04517214.

NOTE 2: This 950IS model transducer must use a Gemco style magnet. See pages 60-62 for magnet options.

NOTE 3: All Intrinsically Safe LDTs include a 6 ft. cable with a straight connector, P/N 04521210. Consult the factory for longer lengths and right angle versions.

NOTE 4: Specify magnet style desired as separate line item. Model number SD0400800 is standard.

NOTE 5: The 950IS is NOT compatible with competitive style magnets. The 950IS MUST use Gemco style magnets.

950IS

9501445 Configuration

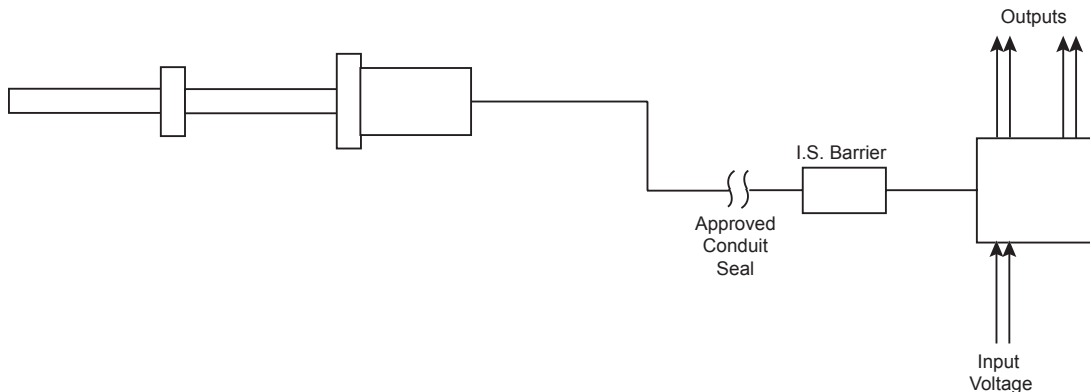

The Gemco 950IS Intrinsically Safe LDT Dimensions & Wiring Diagram

120 VOLT 60 HZ APPLICATION

240 VOLT 60 HZ APPLICATION (Optional)

950IS

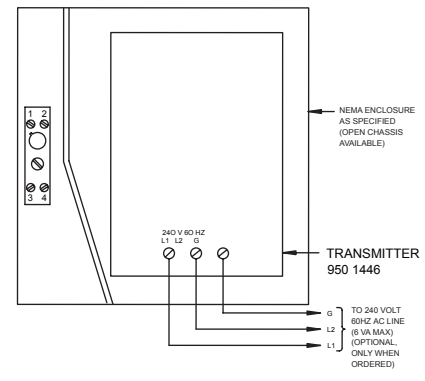
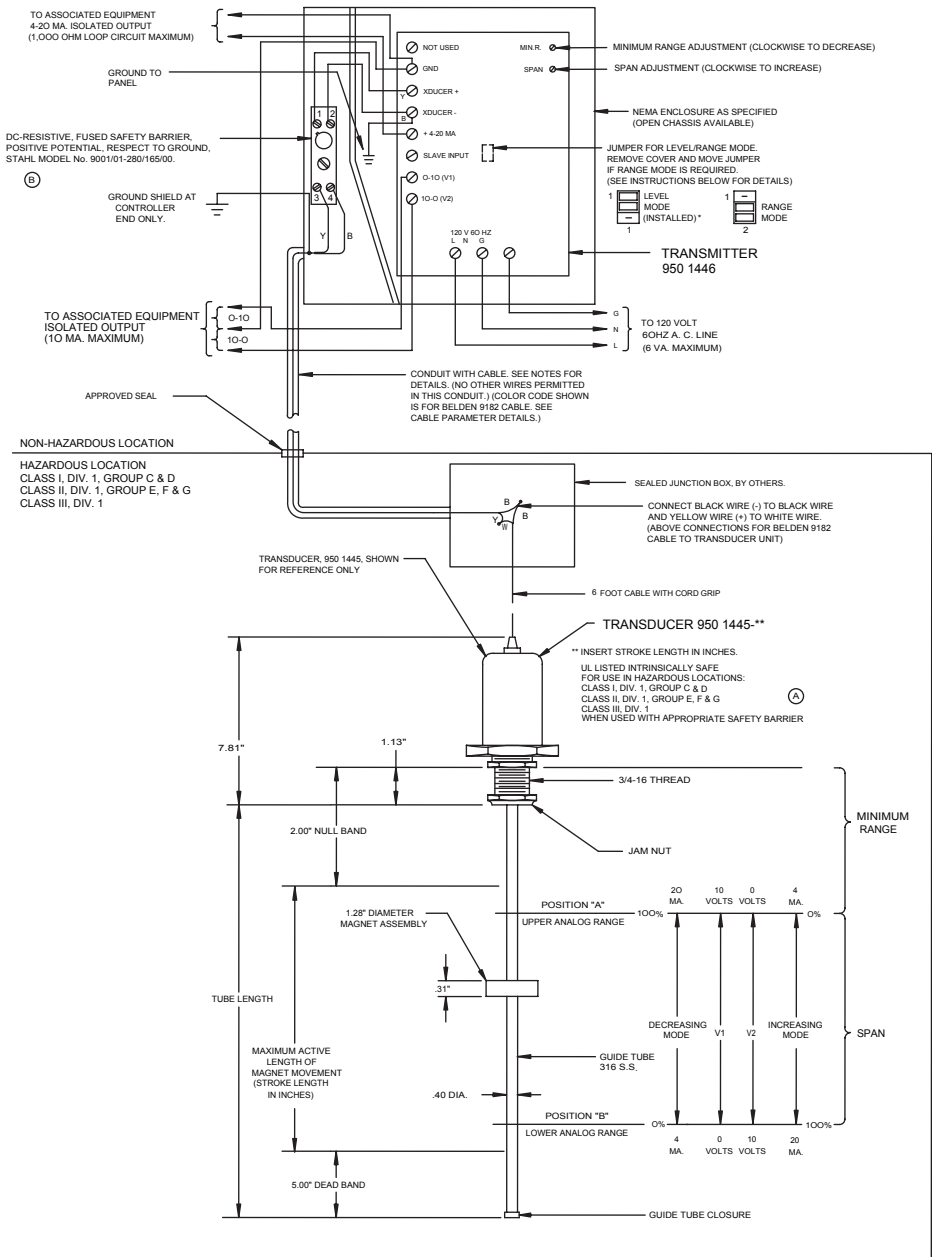

NOTES

- CABLE PARAMETERS**
- USE CONDUIT WITH CABLE INSIDE.
 - NO OTHER WIRES TO BE IN CONDUIT.
 - UP TO 1000 FEET- #22 AWG OR GREATER, TWISTED SHIELDED CABLE, CAPACITY LESS THAN 60 PICO FARAD PER FOOT, INDUCTANCE LESS THAN 2 MICROHENRIES PER FOOT.
 - UP TO 2500 FEET- TWIN AXIAL BELDEN 9182 OR EQUAL. (8.8 PICO FARADS PER FOOT).

CALIBRATION INSTRUCTIONS

- POSITION THE MAGNET AT THE UPPER LIMIT OF THE ANALOG SPAN REQUIRED (POSITION A). WHILE READING OUTPUT V1 (i.e. 0-10 TO GROUND), ADJUST THE "MIN.R." ADJUSTMENT SCREW TO READ 10.00 VOLTS.
- CHANGE POSITION OF THE MAGNET TO THE LOWER LIMIT OF THE ANALOG SPAN (POSITION B). WHILE STILL READING V1, TURN THE "SPAN" ADJUSTMENT SCREW TO READ 0.00 VOLTS.
- IF THE 4 TO 20mA OUTPUT IS REQUIRED, DETERMINE WHICH MODE OF OPERATION IS REQUIRED AND SELECT THE REQUIRED POSITION OF THE MODE JUMPER. LEVEL MODE - CURRENT INCREASES ON RISING LEVEL. RANGE MODE - CURRENT INCREASES ON FALLING LEVEL. THE 0 TO 10 OR 10 TO 0 VOLT OUTPUTS ARE ALWAYS PRESENT.
- THE 950 TRANSMITTER IS NORMALLY SHIPPED WITH THE JUMPER IN LEVEL MODE. THE COVER MUST BE REMOVED BY FIRST REMOVING 4 STAND-OFF SCREWS AND COVER BEFORE CHANGING THE MODE JUMPER.*

*LEVEL MODE - JUMPER ACROSS THE UPPER TWO PINS - POSITION 1.
RANGE MODE - JUMPER ACROSS THE LOWER TWO PINS - POSITION 2.

24 VDC (AT TERMINAL "NOT USED") WILL NOT SUPPORT ANY ADDITIONAL LOADS.

GENERAL INFORMATION

PRIOR TO INSTALLATION, POWER UP THE SYSTEM TO VERIFY OPERATION AND TO FAMILIARIZE YOURSELF WITH THE UNIT.

SEE DRAWING E0198300-B WHEN UL APPROVAL IS REQUIRED ON TRANSDUCER UNIT.

THE TRANSDUCER SHOULD BE HANDLED WITH CARE DURING STORAGE AND INSTALLATION.

Series 950MD Mill-Duty Housing

The series 950 Mill-Duty Housing (950MD) was designed for applications where mounting a stand-alone rod style linear displacement transducer (LDT) is prohibitive. Potential physical damage, environmental conditions or mounting limitations are all elements that are involved in specifying a linear position feedback system that will perform flawlessly for many years to come. The 950MD housing has been designed to eliminate all of the above problems by protecting the LDT from physical and environmental damage such as temperature, corrosives, shock & vibration, or dust and debris. Additionally, the 950MD offers a simple two point mounting scheme that can compensate for lateral and/or horizontal movement of the machine while in operation. Mounting bolts are provided for both the trunnion mount and rod ends in either standard steel or optional Stainless Steel when specified.

The 950MD housing is also perfect for retrofitting existing cylinders with an LDT providing a continuous position feedback signal. The 950MD allows for a convenient way to mount the 950MD and internal LDT parallel to the cylinder. This eliminates the need to tear down and gun drill the cylinder to accommodate an LDT simply for providing position feedback that had not previously been available.

The housing may also be of benefit in this same configuration when you have an existing cylinder in operation that does not allow for an easy removal of the LDT. Old machines and even some existing machines or newly designed machines did not take into consideration the need for continuous position feedback. Certain machines may require that the entire cylinder be removed in order to replace the LDT.

The actuator contains a 1/2" spherical rod end with approximately 1" of adjustment (length). This spherical rod end allows mechanical movement in a horizontal and/or vertical motion to compensate for any mechanical slop or misalignment between the housing and machine. A rear trunnion mount is provided for mounting either directly in front of the head assembly or on the rear of the head. An optional 3/4" spherical rod end can be supplied on the rear of the unit (see drawing for details). The back cap is supplied with threaded and plugged holes that allow for field installation of the 3/4"



950MD

diameter trunnion mount bracket to the back cap. The trunnion mount bracket is positioned at the point where the head and barrel connect. A simple exchange of hardware is all that is necessary to move the trunnion mount bracket to the back cap and plug the no longer required bracket mounting holes. When ordering the 3/4" rear rod end option, the trunnion mount bracket is not supplied since it would not be required.

The actuator rod is supported by two bearings within the guide tube. The front piston bearing contains a wiper assembly to keep contaminants from entering the guide tube. The rear, or movable, bearing assembly is manufactured from Rulon®. This high-temperature polymer material provides low wear and smooth operation.

The transducer magnet is mounted within the rear bearing assembly. The magnet is a 1" O.D. cylinder magnet (SD0410300). The magnet is positioned 2" from the end of the transducer hex when the actuator is fully retracted and 5" from the end of the transducer guide tube when the actuator is fully extended.

The 950MD is designed to incorporate an LDT which has a minimum 2" Null Zone and 5" Dead Band.

950MD Mill-Duty Housing

Due to the fact that the standard Mill-Duty Housing has a mechanical stroke identical to the LDT active stroke, no physical over-stroke exists. If it is possible that the machine being coupled to can extend/retract beyond the stroke supplied, damage to the Mill-Duty Housing and possibly to the machine might occur. To compensate for this we call out fully retracted/fully extended over-stroke dimensions for the Mill-Duty Housing. These values are essentially the additional stroke length added to the Mill-Duty Housing. The reason they are called out separately is to alert the user that when entering these areas, they are out of the LDT active stroke area. If an extended over-stroke is specified, the LDT must be ordered with a Dead Band of 5" + X (extended stroke value). If a retracted over-stroke is specified, the LDT must be specified with a Null value of 2" + Y (retract over-stroke value).

The Mill-Duty Housing offers either a conduit entrance for hard wiring directly to the LDT within the head or an external connector and mate. The connector attaches to the LDT inside of the housing via a small pigtail connector within the head.

Detailed Product Description and Materials of Construction

The 950MD consists of a 304 Stainless Steel body, barrel, piston, head and trunnion mount bracket.

The standard 1/2" diameter rod end with mounting bolt, the 3/4" diameter trunnion mounting bolt, and some of the optional MS connectors on the head are the only items that are not Stainless Steel on the standard assembly. This is also true of the optional 3/4" diameter front and rear rod ends with their mounting bolts. These rod ends and all mounting bolts can be ordered in Stainless Steel as an option. The 12mm Euro connector options C3 and C4 come standard in Stainless Steel. Consult the factory for further details.

The 950MD head assembly is removable to allow installation of a rod style LDT that will screw into the standard 3/4" - 16 x 1.00 mounting thread. An optional Metric thread of M18 X 1.5 can also be supplied upon request. The head contains a 1/2"



NPT conduit port for wiring to the LDT or optionally an MS connector can be installed for the external wiring. Use of the MS connector will require that the LDT also have a connector on it in lieu of a potted cable. This will allow for a quick connect at the LDT head internally and on the 950MD head externally. The 950MD head is sealed with O-rings and also contains two threaded air purge openings that are plugged but available for use to air cool the LDT head with filtered and regulated air. By removing the plugs and installing the proper size air fittings, you can cool the head electronics for high temperature applications. An optional Vortex air cooler may also be specified for the head and/or barrel or an optional water jacket for the LDT can be supplied. See the 950MD dimension drawings for further details.

**Consult Factory if installing
950IS into 950MD Housing**

950MD Mill-Duty Housing

Applications

The 950MD was originally designed for use in steel mill applications but has proven to be reliable in many applications where ruggedness, environmental protection and ease of mounting are required. Some of these applications include:

Steel Mills - Tundish car (Tundish height), turret height (Caster), hydraulic coil cars, torch cutoff machine (torchhead monitoring), furnace tilt, electrode positioning, side guide positioning, ladle slide gate positioning, louver or roof position, etc.

Foundries, Forging and Casting – Linear transducers with 950MD housings have been used on sand mold compactors, furnace or oven doors and material transfer systems.

Injection Molding and Die Casting – Proven effective in monitoring/controlling the position of the clamp and/or shot cylinder. The two point connection of the 950MD housing allows for a simple retrofit by replacing limit switches with an LDT for position feedback over the entire range movement. Linear potentiometers can also be replaced, thus eliminating their problems with drift, temperature, and short life span.

Hydraulic Servo Applications - Ideal for installing parallel to hydraulic cylinders including new applications and retrofits. The major advantage to using the 950MD housing versus gun drilling the cylinder for an LDT is that the cylinder fluid flow is not compromised. If an LDT fails within a cylinder it cannot be removed without having to deal with the hydraulic fluid lines, pressure etc. Some cylinders may be difficult to remove once installed, thus inhibiting the removal of the LDT. The 950MD housing is typically mounted parallel to the cylinder, the same as a slave cylinder would be, so removal is greatly simplified under these conditions.

Lock and Dam Sites - Miter gate and Tainter valve position feedback systems have both benefited from the 950MD and LDT combination.

Gate Position Feedback - For hydro-electric plants, water control structures, water and wastewater treatment and managing, wicket gate position feedback for Turbine speed control.

Optional Items

The standard Mill-Duty Housing includes the complete

housing assembly with provisions to accept an LDT and all bolts, nuts and mounting hardware required for a complete installation. There are also several optional items available.

Vortex Air Cooler - The standard 950MD is equipped with air purge ports. In many cases, running clean shop air through the head is sufficient to cool the electronics. For severe temperature applications a Vortex Air Cooler may be desired. A Vortex Air Cooler accepts standard shop air (80 - 100 PSIG). The air is ejected through a generator in a Vortex spin chamber where the air stream revolves in a tube at up to 1,000,000 RPM. In simplest terms the inner stream gives off energy in the form of heat to the outer stream and the inner stream exits the opposite end as hot air. The Vortex Cooler is capable of generating air flows as cold as -40° F.

Protective Boots - To give added protection to the actuator rod, protective boots are available. These boots attach between the end of the Mill-Duty guide tube and the end of the actuator rod assembly. The boots are offered in neoprene coated nylon for most standard applications. They offer -60° F to 250° F operating range with resistance to water and oil. Also, silicone coated fiberglass offers high temperature resistance from -100° F to 550° F; Teflon-coated fiberglass offers -100° F to 500° F operating range with a high degree of corrosion resistance and optional stainless steel boots for rugged applications.

Water-Cooled Head Assemblies - In applications where extreme temperatures are present and air cooling is not appropriate, water-cooled head assemblies are available. Cooling jackets within the head assembly allow water to flow around the electronics.

Front and Rear Mount Spherical Rod Ends - In applications where two spherical rod ends are required, rear mount spherical rod ends are available. The 3/4" rear rod end attaches to a threaded bolt extending from the rear of the head. The 3/4" front rod end is threaded into the piston rod. An optional stainless steel version is available. Mounting bolts are supplied with both versions.

Delrin Liner - Used in longer horizontal applications, typically 60" or longer to prevent wear on the LDT's guide tube as the 950MD housing is stroked. The Delrin liner is installed inside of the 950MD barrel and prevents sag of the LDT's guide tube.

950MD Mill-Duty Housing Part Numbering

950MD — 12A — 0B — 0C — X — X

Active Stroke in Inches
Determine the "active" stroke to be measured followed by "A".

Fully Retracted Overstroke in Inches
Insert length of retract overstroke in inches followed by "B". If no retract overstroke is required, simply insert "0B".

Fully Extended Overstroke in Inches
Insert length of extend overstroke in inches followed by "C". If no extend overstroke is required insert "0C"

Connector	
X	Standard 1/2 inch NPT conduit fitting (It is suggested to order a quick disconnect connector on the LDT)
C2	Environmental 10 pin MS connector and mate on side of housing (for use with 951, 952, and 953 LDT's with connector option E only)
C3	5 Pin, 12mm, Euro Connector on Side of Housing (for 952A/953A w/connector option S only)
C4	6 Pin, 12mm, Euro Connector on Side of Housing (for 953D and SSI w/connector option S only)
C5A	10 Pin STD - to 953A 5 Pin Euro
C5D	10 Pin STD - to 953D 6 Pin Euro
NC	No Head Cover on the 950MD Housing
W	Special Head cover for LDTs using a water cooled jacket. Allows entry and exit of water lines. NOTE: This option does not support connector option C, C2 or C3.
CGP	Cord grip PVDF for cable diameter .1"- .3"
CGA	Cord grip stainless steel for cable diameter .19"- .25"
CGB	Cord grip stainless steel for cable diameter .25"- .31"
CGC	Cord grip stainless steel for cable diameter .31"- .38"

Options	
X	None
V	Vortex air cooler
B1	Protective boot - neoprene coated nylon (-60F to +250F)
B2	Protective boot - silicone coated fiber glass (-100F to +550F)
B3	Protective boot - teflon coated fiber glass (-100F to +500F)
R	Rear mount spherical rod end 3/4"
F	Front mount spherical rod end 3/4"
RS	Stainless steel rear mount spherical rod end 3/4" with 304 stainless steel mounting bolt
FS	Stainless steel front mount spherical rod end 3/4" with 304 stainless steel mounting bolt
L	Delron liner for extended life cycle on longer horizontal applications (used to protect the LDT's rod assembly)
SB	304 stainless steel boot
A	Barrel air purge

Note 1: Guide tube support brackets are supplied as standard for strokes of 72" or greater.

Note 2: Special high temperature, abrasion resistant and oil resistant cables are available. Consult your Customer Service Representative.

950MD Compatibility Guide	
940	Yes
950IS	Consult Factory
951	Yes (Must be ordered w/2" Null Zone & 5" Dead Band)
952	Yes (Must be ordered w/2" Null Zone & 5" Dead Band)
953	Yes (Must be ordered w/2" Null Zone & 5" Dead Band)
955	See 956 Section
7330	Consult Factory

950 LDT Cable Assemblies	
Item	Part Number
Cable Assembly with Mate for Option "C" Connector Style, 6 Feet, (For 950-CP)	SD0436700L6
Cable Assembly with Mate for Option "C" Connector Style, 6 Feet, (For 950A/950TP)	SD0436000L6

Accessories	
Item	Part Number
Vortex Cooler	04578009
Muffler for Cooler	04578010
Replacement 1/2" Spherical Rod End	04570140
Guide Tube Support Bracket (See note 1)	C0903400
Replacement (Male Connector) for Option "C2" Connector	04521407
Female Mating Connector for Option "C2" Connector	04521372
Replacement (Male Connector) for Option "C3" Connector	04521568
Replacement Piston & Magnet Sub Assembly	SD0452400
Replacement Housing bushing & Seal Sub Assembly	SD0563300

951, 952 and 953 LDT Cable Assemblies	
Item	Part Number
Cable Assembly with Mate for Option "C2", C5S, and C5D Connector Styles, 6 Feet	SD0439700L6
5 Pin, Straight, Stainless Steel Cable Assembly with Mate for Option "C3" Connector Style, 6 Feet	949013L6
6 Pin, Straight, Stainless Steel Cable Assembly with Mate for Option "C4" Connector Style, 6 Feet	949031L6

950MD Mill-Duty Housing Standard 950MD

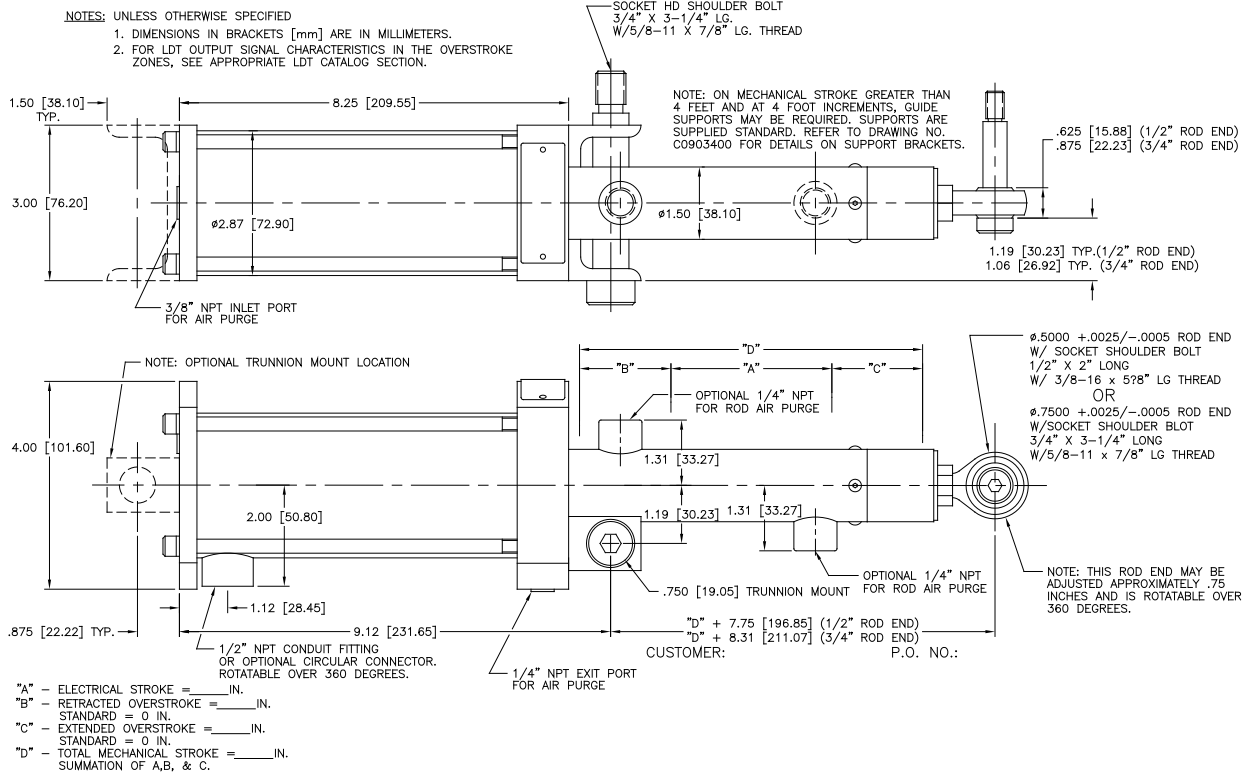

950MD

Mill-Duty with Rear Mount Spherical Rod End

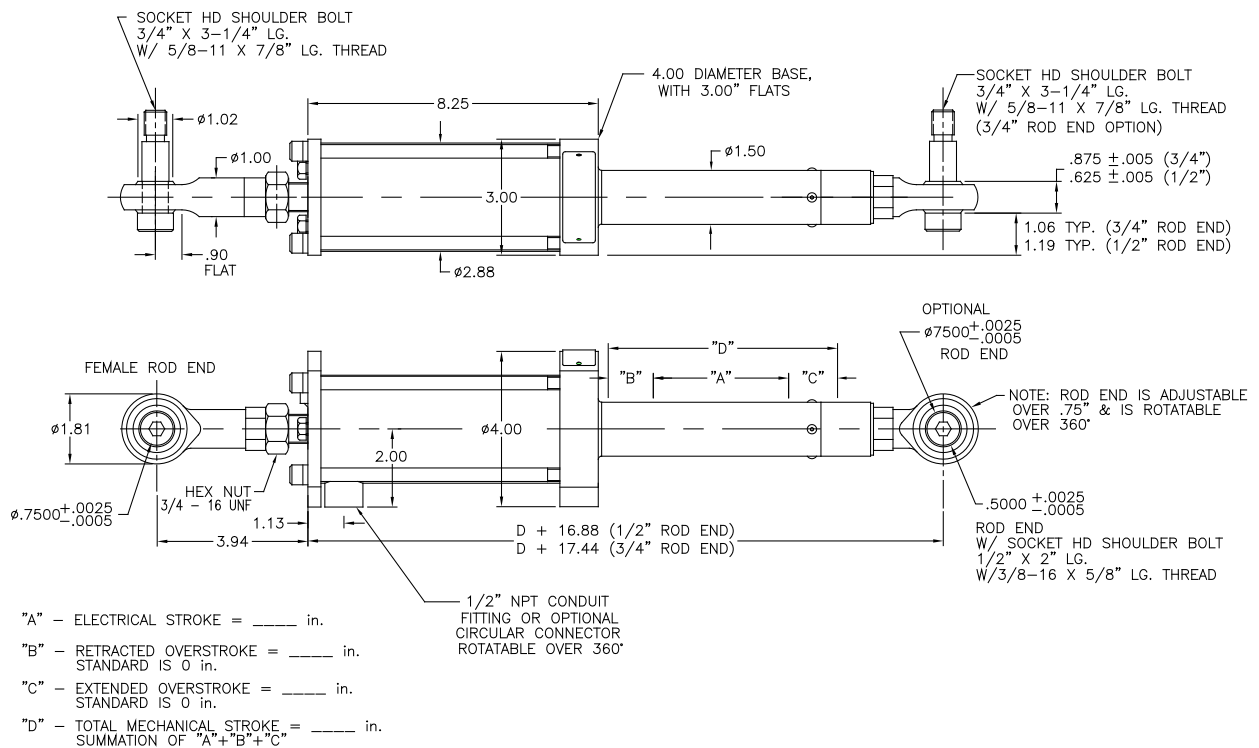

952 BlueOx

Magnetostrictive LDT for High Shock and Vibration Areas

Gemco brand position sensing products have been known for survival in harsh industrial environments. We have taken over twenty years experience in magnetostrictive linear sensors and married it with our understanding of rugged industrial sensors to develop the BlueOx LDT as the industry's first truly rugged magnetostrictive linear transducer.

The BlueOx LDT is lab tested and field proven to stand up to high shock and vibration. With test results of 2,000 Gs of shock and 30 Gs of random vibration without false signals or mechanical damage, the BlueOx LDT is ready to perform on the most demanding applications.

In addition to its ability to withstand shock and vibration, the BlueOx LDT is rugged in other ways. Sensing tube construction is welded stainless steel, suitable for insertion in 5000 PSI hydraulic cylinders. The electronics are enclosed behind an aluminum housing with O-ring seals for IP67 indoor applications (Type Nema 6 rating and stainless steel covers and connectors are available as a special option).

The 952 BlueOx is available with Analog, Control Pulse, Variable Pulse or RS422 Start/Stop outputs. The 952 is compatible with PLC interface cards and our 1746 LDT Interface Card. The 16 bit resolution analog output is programmable over the entire active stroke length. The units can easily be changed in the field from a 0 - 10 VDC to a 10 - 0 VDC or a 4 - 20mA to a 20 - 4mA. As an added feature, the optional differential analog output allows the distance between two magnets to be measured.

The BlueOx, with its high resolution and rugged construction, is at home in heavy duty areas such as lumber mills, steel mills, stamping plants, assembly automation, material handling, robotics and any other industry where highly accurate and reliable continuous linear position sensing is needed.



Specifications	
Input Voltage	Analog: 13.5 to 30 VDC Digital: 13.5 to 26.4 VDC, or +/- 15 VDC
Current Draw	< 200mA at 15 VDC
Output	Analog: 0 to 10 VDC or 10 to 0 VDC, 4 to 20mA or 20 to 4mA Digital: Start/Stop, Control Pulse or Pulse-Width Modulated/ Variable Pulse (PWM/VP)
Resolution Internal Analog Output	0.001" 16 Bit (1 part in 65,535)
Linearity	+/-0.05% of Full Scale
Repeatability	+/-0.006% of Full Scale (+/- .002 inch min.)
Hysteresis	+/-0.02% of Full Scale
Operating Temperature Head Electronics Guide Tube	-40° to 158° F (-40° to 70° C) -40° to 221° F (-40° to 105° C)
Operating Pressure	5000 psi Operational, 10,000 psi Spike
Span Length	2" to 168"
Null Zone	2"
Dead Band	2.5"
Connectors	12mm Micro 5 Pin, CE Approved (Analog Only), 10 Pin 1/4 Turn MS Connector, Potted Pigtail Assembly, Optional Tempsonics II & III Connectors
Update Time Analog	1ms (Stroke Lengths 1" to 50") 2ms (Stroke Lengths 51" to 100") 3ms (Stroke Lengths 101" to 150") 4ms (Stroke Lengths 151" to 168") Controller Dependent
Digital	
Enclosure	IP67
Approvals	CE (Analog 12mm Micro 5 Pin Connector Only)
Specifications are subject to change without notice. Specifications are based on a typical 36" LDT .	

952 BlueOx Dimension Drawing

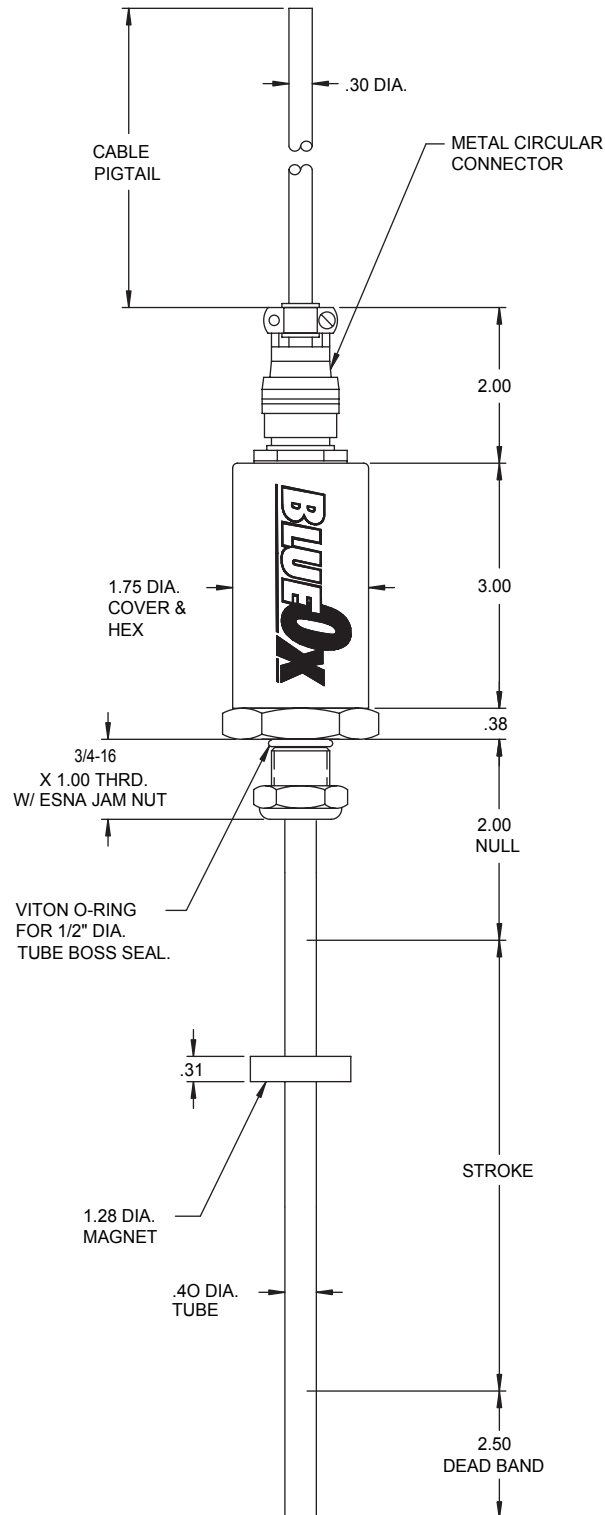

952

952A BlueOx Part Numbering

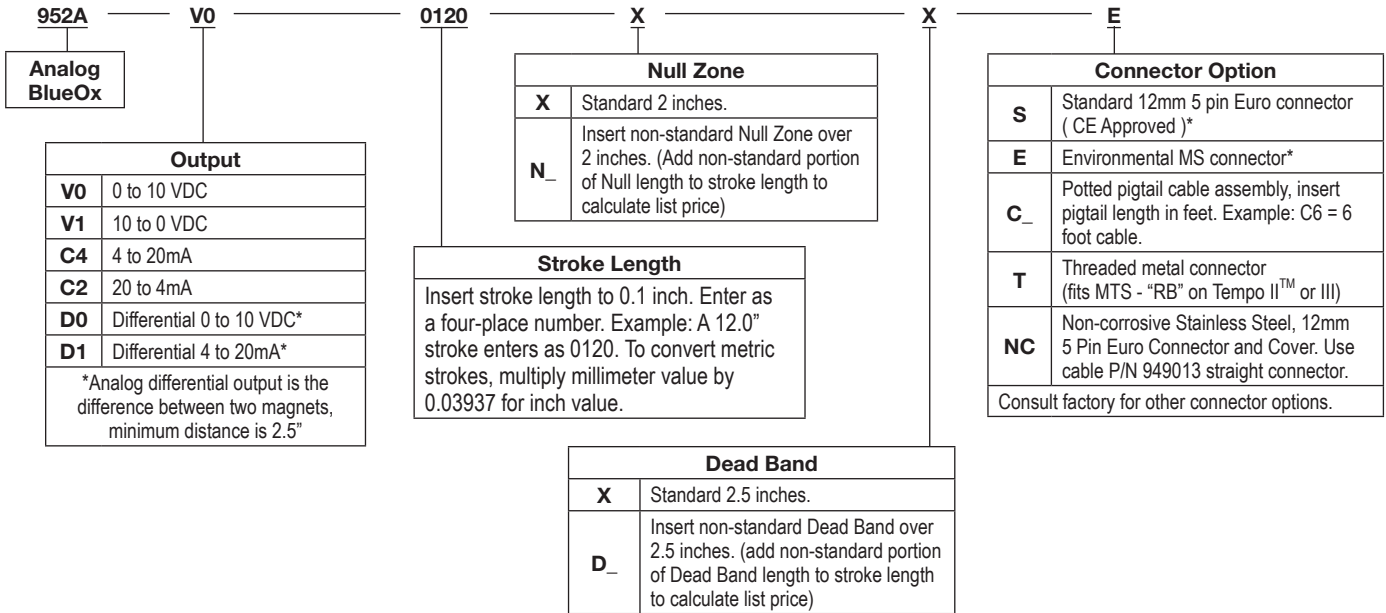

Note 1: On unsupported stroke lengths greater than 4 feet, rod support bracket(s) and a special magnet should be used.
Note 2: Specify magnet as separate line item (standard magnet is SD0400800).

* If option S or E (environmental connector) is selected, mating connector and/or cable assembly must be ordered separately.

952

Wiring Diagram Option "S"

Use Euro Connector (micro 12 mm single keyway) cordsets, available from most connector manufacturers or purchased from Ametek.

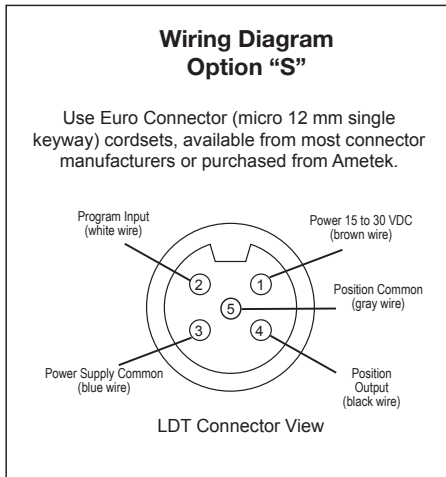

Wiring Diagram Option "E"

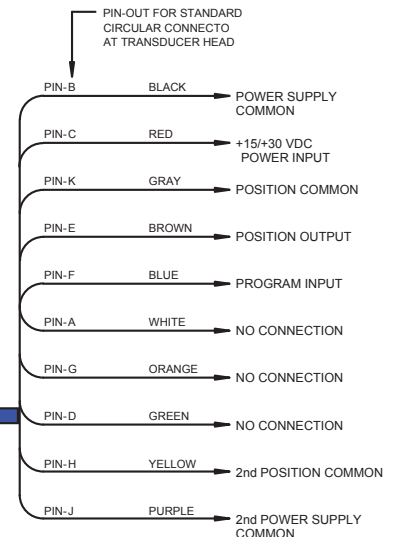

952CP BlueOx Part Numbering

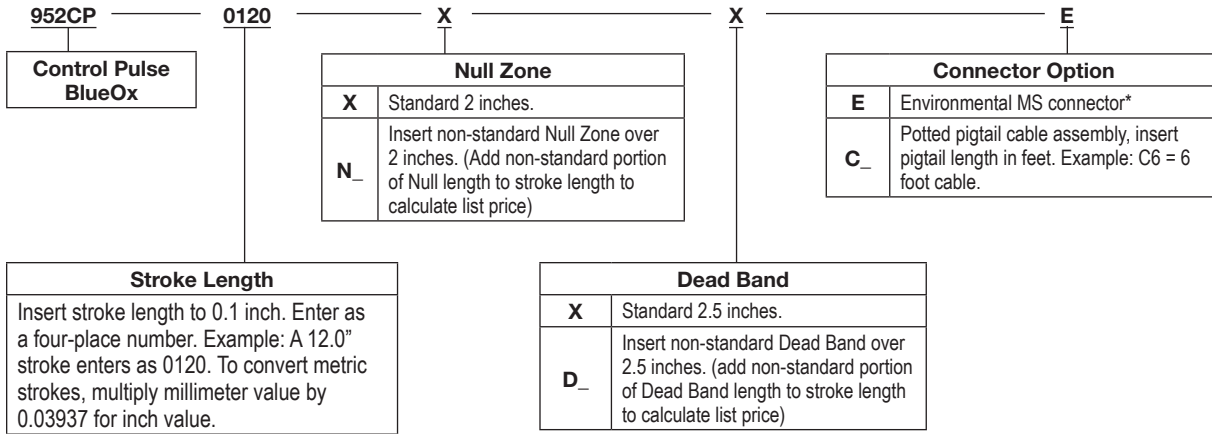

* If option E (environmental connector) is selected, mating connector and/or cable assembly must be ordered separately.

Note 1: On unsupported stroke lengths greater than 4 feet, rod support bracket(s) and a special magnet should be used.

Note 2: Specify magnet as separate line item (standard magnet is SD0400800).



Wiring Diagram

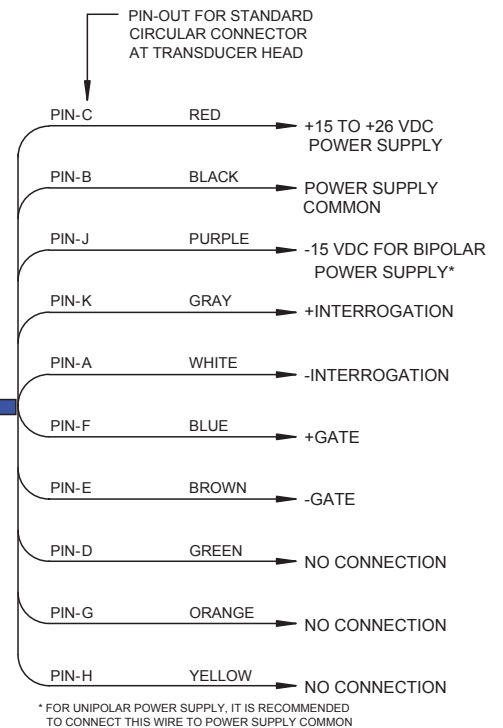

952VP BlueOx Part Numbering

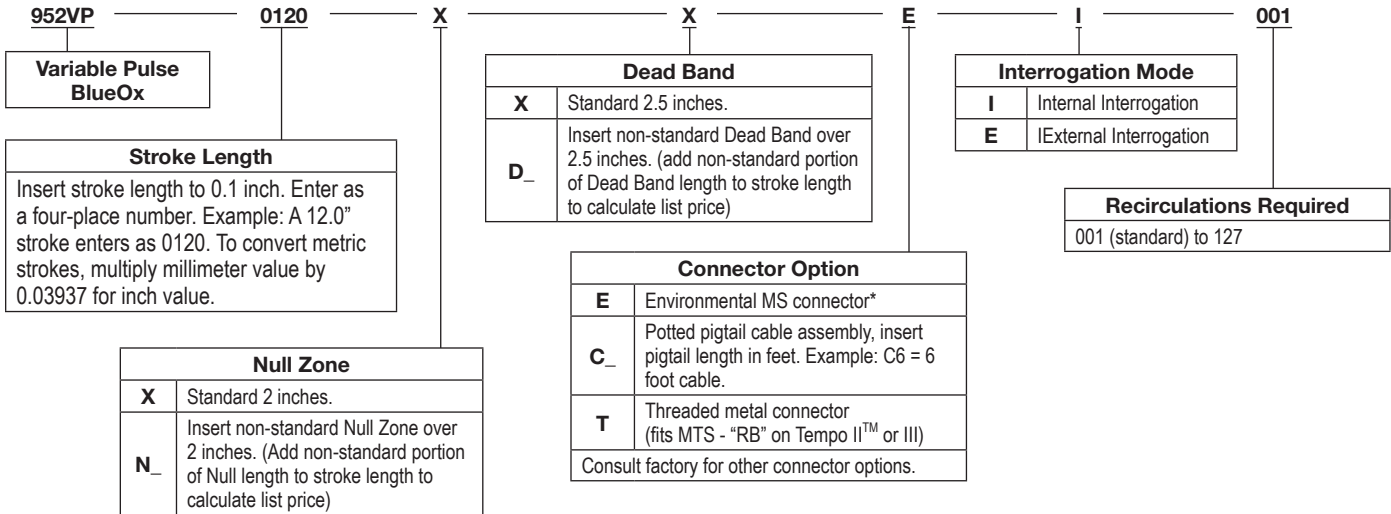

* If option E (environmental connector) is selected, mating connector and/or cable assembly must be ordered separately.

952

Note 1: On unsupported stroke lengths greater than 4 feet, rod support bracket(s) and a special magnet should be used.

Note 2: Specify as magnet separate line item (standard magnet is SD0400800).

Wiring Diagram

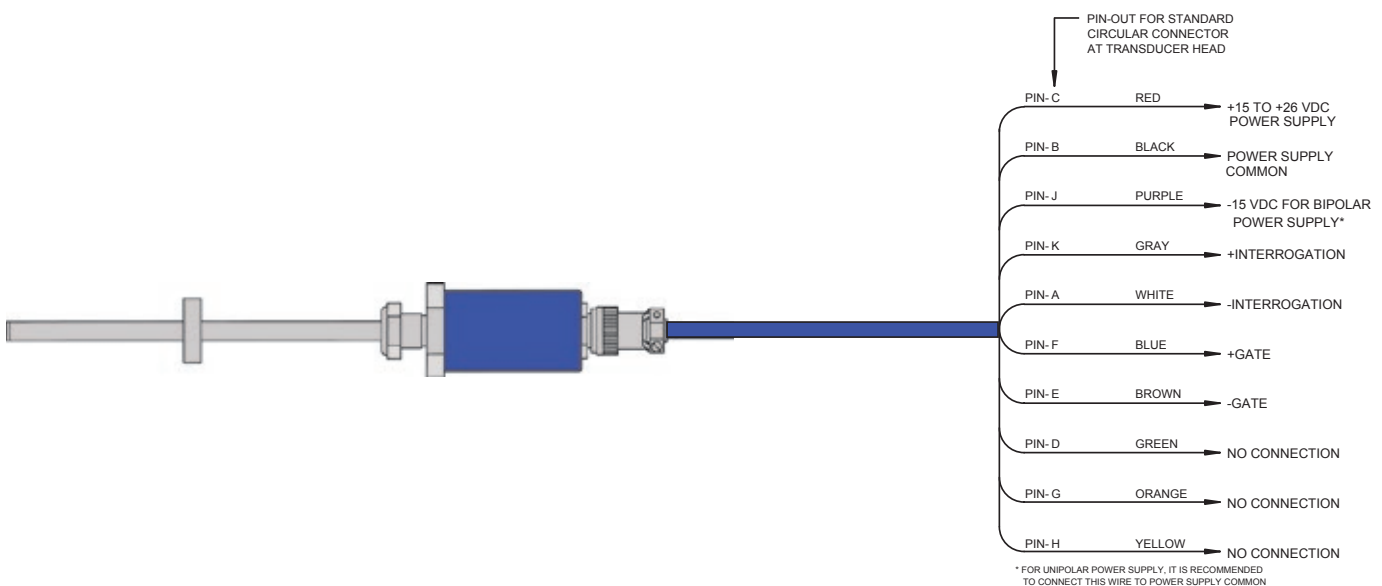

952RS BlueOx Part Numbering

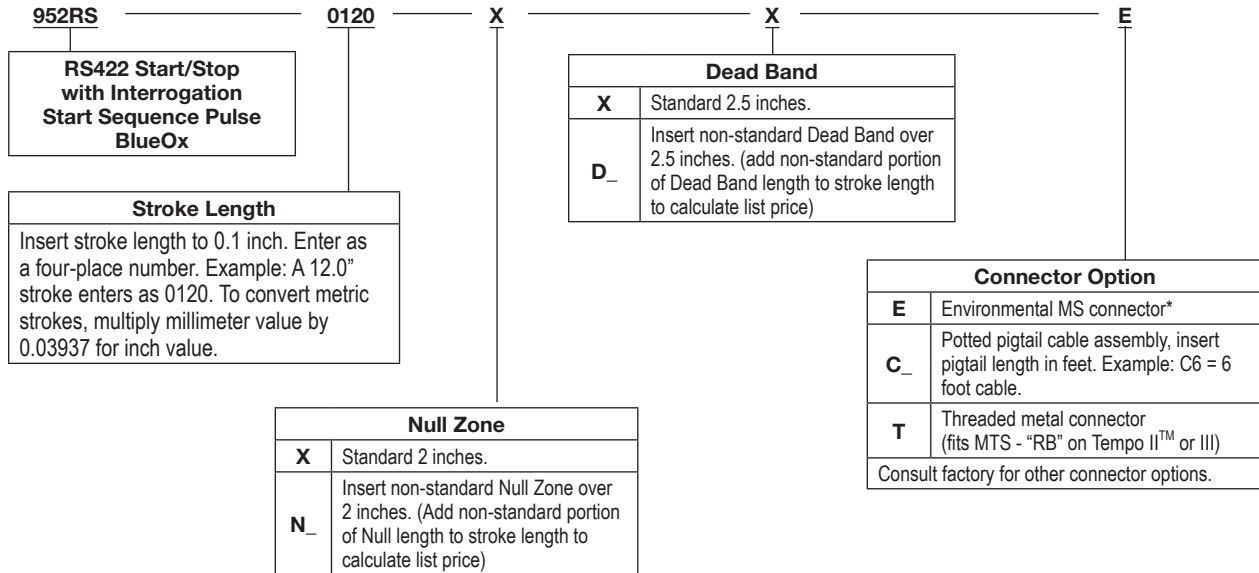

* If option E (environmental connector) is selected, mating connector and/or cable assembly must be ordered separately.

Note1: On unsupported stroke lengths greater than 4 feet, rod support bracket(s) and a special magnet should be used.

Note 2: Specify magnet as separate line item (standard magnet is SD0400800).



Wiring Diagram

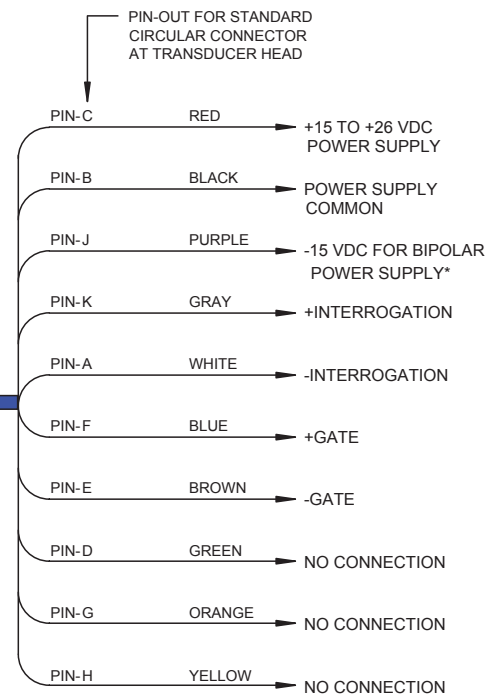

* FOR UNIPOLAR POWER SUPPLY, IT IS RECOMMENDED TO CONNECT THIS WIRE TO POWER SUPPLY COMMON

952QD BlueOx Magnetostrictive LDT with Quadrature Output

The BlueOx Quadrature is a magnetostrictive linear displacement transducer (LDT) for continuous machine positioning in a variety of industrial applications. The quadrature output makes it possible for customers to have a direct interface to virtually any incremental encoder input or counter card, eliminating costly absolute encoder converters and special PLC interface modules.

The BlueOx Quadrature LDT is lab tested and field proven to stand up to high shock and vibration without effect. With test results of 2,000 Gs of shock and 30 Gs of random vibration without false signals or mechanical damage, the BlueOx Quadrature LDT is ready to perform in the most demanding applications.

The BlueOx Quadrature LDT can be ordered with 1 to 9999 cycles per inch of output resolution and the position data is absolute. The transducer features an input to re-zero the probe “on the fly”. Another unique feature is the “burst” mode. An input on the transducer triggers a data transfer of all the incremental position data relative to the transducer’s absolute zero position. This can be used to achieve absolute position updates when power is restored to the system.

The BlueOx Quadrature is shipped from the factory pre-calibrated and ready for installation. In addition to its ability to withstand shock and vibration, the BlueOx Quadrature is rugged in other ways. Sensing tube construction is welded stainless steel, suitable for insertion in 5,000 PSI hydraulic cylinders.

The electronics are enclosed behind an aluminum housing with O-ring seals. The BlueOx Quadrature LDT, with its rugged construction, is at home in heavy duty areas such as lumber mills, steel mills, stamping plants and any other harsh environment where accurate and reliable continuous linear position sensing is needed.



Specifications	
Input Voltage	13.5 to 26.4 VDC
Current Draw	< 200mA at 15 VDC
Output	Quadrature Output A+, A-, B+, B-, Z+, Z-. Line Drivers: 5V or Input Power
Inputs	10 to 30 VDC
Resolution	0.001"
Linearity	<.05% (+/- .002" Min)
Repeatability	0.001% of Full Stroke (+/- .002" Min.)
Hysteresis	+/- .02% of Full Scale
Operating Temperature	-40° to 155° F (-40° to 70° C)
Head Electronics	-40° to 220° F (-40° to 105° C)
Guide Tube	
Operating Pressure	5000 PSI Operational, 10,000 PSI Spike
Span Length	2" to 168"
Null Zone	2.0"
Dead Band	2.5"
Connectors	1/4 Turn MS Connector Standard. Potted Pigtail Assembly Available Optionally
Update Time	Approx. 1ms for 1" to 50" Approx. 2ms for 51" to 100" Approx. 3ms for 101" to 150" Approx. 4ms for 151" to 168"
Enclosure	IP67
Specifications are subject to change without notice. Specifications are based on a typical 36" LDT .	

952QD BlueOx Magnetostrictive LDT with Quadrature Output

Dimension Drawing

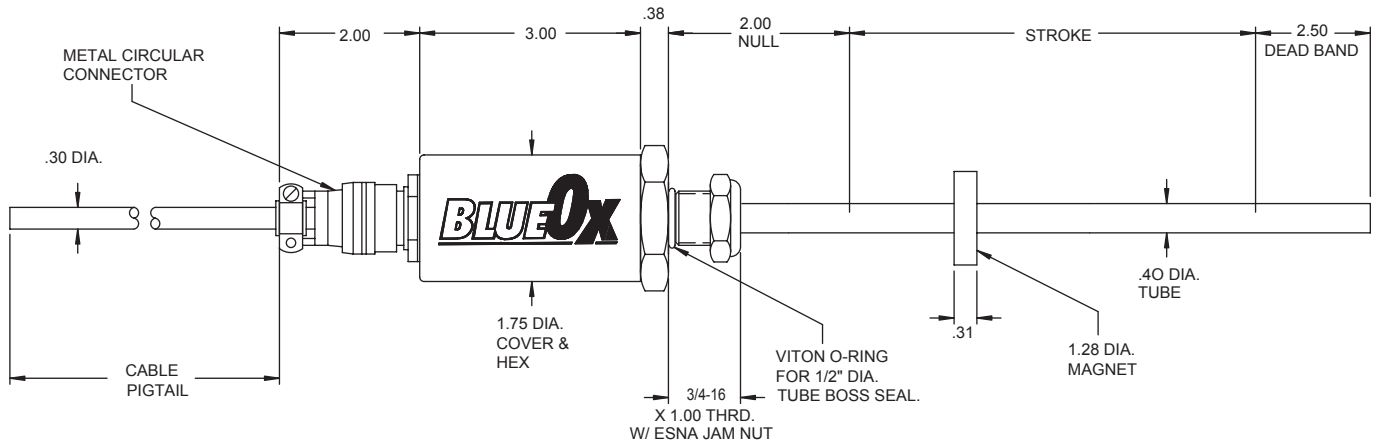

Wiring Diagram

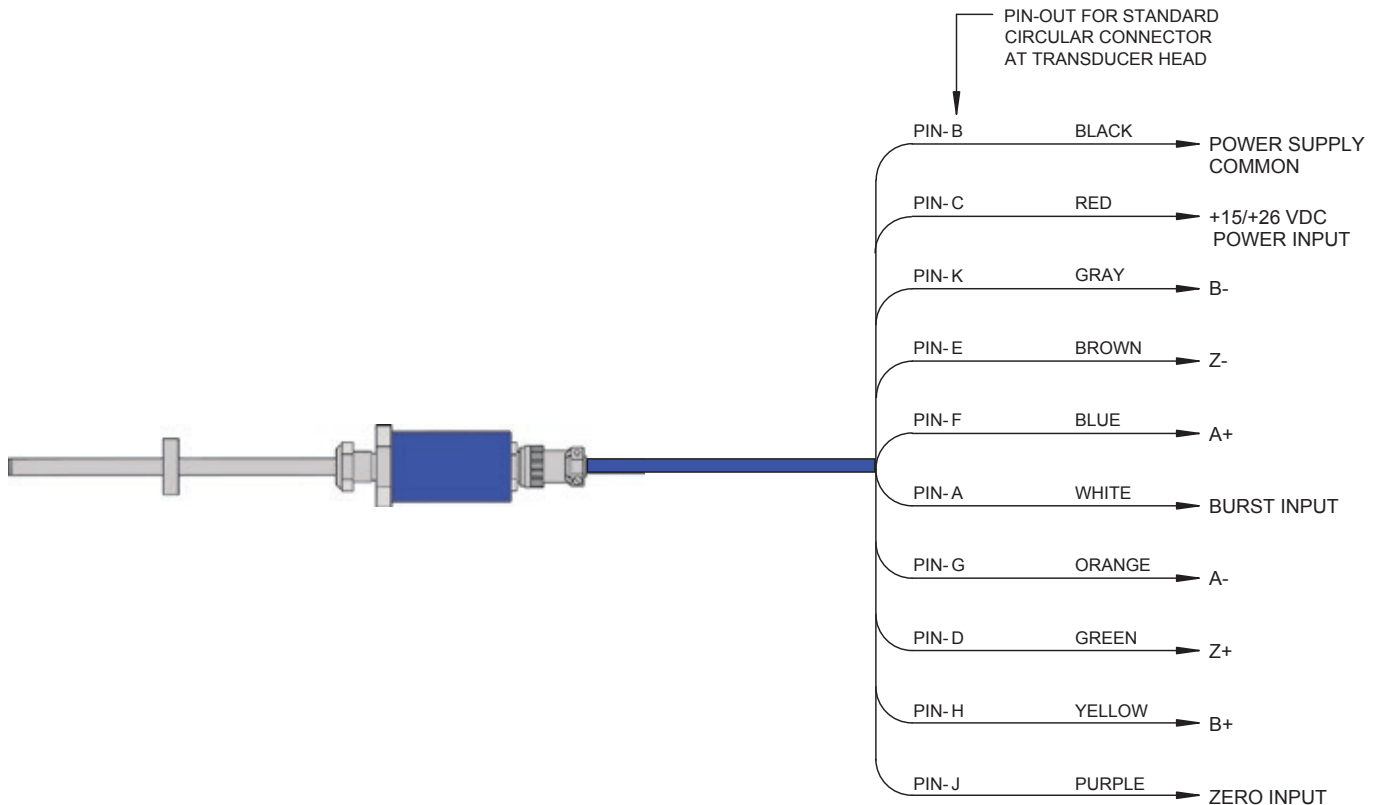

952

952QD BlueOx Magnetostrictive LDT with Quadrature Output

Part Numbering

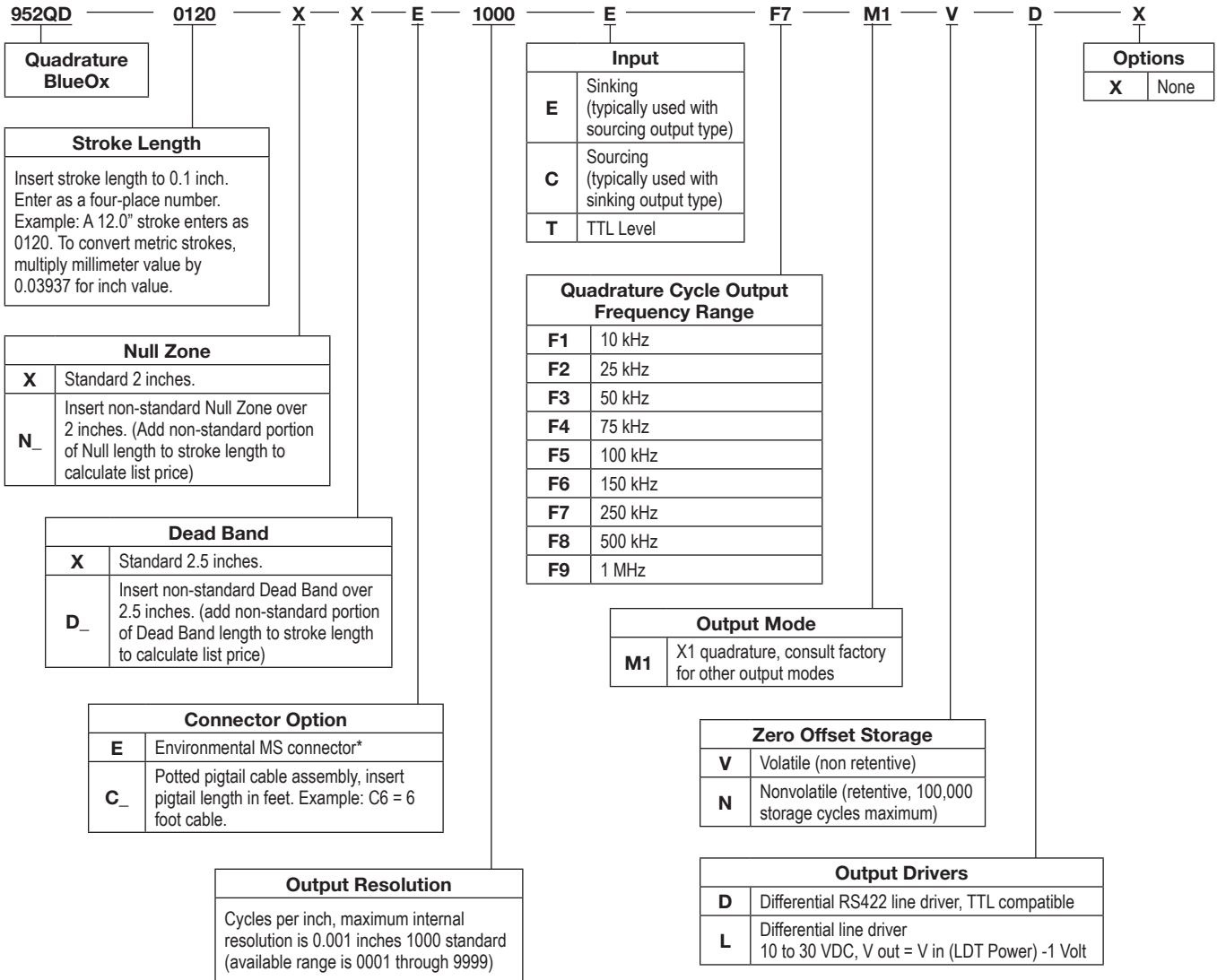

* If option E (environmental connector) is selected, mating connector and/or cable assembly must be ordered separately.

953A/D/SSI VMAX™ LDT

Mobile Equipment and Stationary Processing Systems demand absolute accuracy and reliability in linear position feedback . . . Regardless.

Innovation, proprietary technology and decades of experience were the key to the development of our 953 VMAX Linear Displacement Transducer.

We know the manufacturing challenges of today are extreme, so we designed and built a sensor to meet and exceed these demands, regardless of the application or environment.

Introducing the 953 VMAX LDT features:

- High Vibration Resistance to 30 Gs (lab tested)
- High Shock Resistance to 1000 Gs (lab tested)
- Wide Input Power Range of 7 to 30 VDC (no need to specify different models)
- High Accuracy with High Resolution
- Applications Include All Mobile/Stationary Equipment, or Both with the Same Sensor
- Sensor Lengths up to 300"
- Durability and Reliability Exceeds Competitive Offerings
- Tri-Color Diagnostic LED Indicator
- Gives Quick Indication on the Status of the LDT
- Very Low Power Consumption, 1 Watt Typical, Allows Direct Connection to Display and Control Interface Modules
- Removable Cartridge for Hydraulic Applications
- Digital Output, Start/Stop, Variable Pulse (PWM), Control Pulse
- SSI (Synchronous Serial Interface), 24, 25 or 26 Bit, Binary or Gray Code, Position Update
- Analog Output, 0-10 VDC, +/-10 VDC, 0-5 VDC, +/-5 VDC, 4-20mA
- Contaminant Resistant
- IP68 Rated
- Optional Stainless Steel Cover and Connector
- Multi-Magnet Option (Digital Start/Stop only)

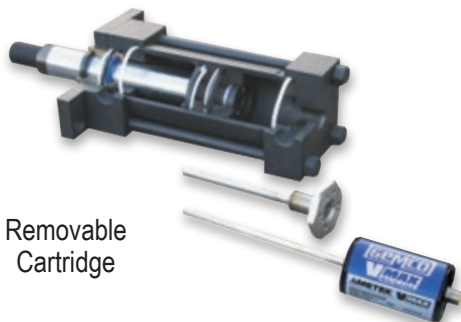

Applications Include

Absolute linear position feedback for equipment and process automation in extreme applications.

Process Automation

- Steel Mills, Primary and Secondary Metals Processing that includes Stamping, Roll Forming and Die-Casting
- Hydraulic & Pneumatic Cylinders
- Adaptive Housing Options to Withstand Extreme Temperatures and Contaminants (Gemco 950MD units)

Mobile Equipment

- Lumber and Forest Products Processing
- Refuse Collection, Vehicles, Recycling and Compaction
- Off Road

Stationary Machines

- Sawmill, Plastic, Rubber, Injection Molding, Extrusion Equipment, Material Handling, Nonwoven, Dancers and Accumulators

953A/D/SSI VMAX™ LDT

Specifications					
953SSI Connector Interface	6 Pin 12mm Euro micro, Standard. Integral cable ass'y, 7 Pin or 8 Pin DIN - option	Shock	1000 Gs (lab tested) IEC 60068-2-27	953SSI Output	24, 25 or 26 Bit, Binary or Gray Code (optional parity and error bit), Position Update
953D Connector Interface	6 Pin 12mm Euro micro, Standard. Integral cable ass'y, 6 Pin or 8 Pin DIN or 10 Pin MS- Optional	Vibration	30 Gs (lab tested) IEC 60068-2-6	953D Output	RS = RS422 Start/Stop Pulse VP = RS422 Variable Pulse (PWM), Internal/External Interrogation CP = RS422 Control Pulse TP = TTL Start/Stop Pulse
953A Connector Interface	5 Pin 12mm Euro micro, Standard. Integral cable ass'y, 6 Pin or 8 Pin DIN or 10 Pin MS- Optional	953SSI Update Time	Measuring Length 300 750 1000 2000 5000mm Measurements/ 3.7k 3.0k 2.3k 1.2k 0.5k sec.	953A Output Voltage Current	0-10 VDC, +/-10 VDC, 0-5 VDC, +/-5 VDC 4-20mA
Sensor Housing and Mounting Hex	Body length 3.2", hex base 1 3/4" dia., 3/4"x16x1" thread. Aluminum housing standard, stainless steel optional.	953D Update Time	Controller Dependant	953A Current Output	Max Load Resistance: 500 Ohms
Displacement	1" to 300"	953A Update Time	< 2mS Typical	953A Voltage Output	Minimum Load Resistance: 2K Ohm Output Current: Guaranteed 5mA minimum Analog Ripple: ≤1 mV maximum
Dead Band	2.50" (63.5 mm) standard, (2.25" Minimum)	Guide Tube Pressure	5,000 psi continuous (10,000 psi spike)	Hysteresis	0.001"
Null Zone	2.00" (50.8 mm) standard, (1.5" Minimum)	Approvals	CE (EMC)	Non-linearity	< 0.01% or +/- 0.005", whichever is greater, (+/- 0.002 Typical)
Enclosure Rating	IP68, IEC 600529	Input Voltage	7 to 30 VDC	Storage Temperature	-40° to 221° F (-40° to 105° C)
953SSI Resolution	English or Metric Units Metric: 1, 5, 10, 20 micron (5 micron standard) English: .00005", .0001", .0005", .001" Consult Factory for Others.	953A Zero & Span Adjustability	Factory set at Null & Dead Band locations Field re-settable at any location within active stroke	Operating Temperature Head Guide Tube	-40° to 185° F (-40° to 85° C) -40° to 221° F (-40° to 105° C)
953D Resolution	Controller Dependant	953D Repeatability 953A Repeatability 953SSI Repeatability	Equal to Resolution of Controller Equal to Resolution Equal to Output Resolution	Diagnostics	Tri-Color LED beside connector/cable exit, See 'LED Output Summary Table' on page 31
953A Resolution Internal Output	0.00006" 16-Bit	953SSI Measured Variables	Single Magnet Displacement, Consult Factory for Velocity or Differential Operation		

NOTE: Specifications subject to change and are based on a typical 48" stroke.
*One watt typical at 1ms interrogation time with no recirculations. Faster interrogation times and/or recirculations increase power consumption.

SSI (Synchronous Serial Interface)

Displacement value is encoded into a 24, 25 or 26 Bit format and transmitted at high speeds. Synchronization in a closed loop system is made easy. A clock pulse train from a controller is used to gate out sensor data: one bit of position data is transmitted to the controller per one clock pulse received by the sensor. The absolute position data is continually updated by the sensor and converted by the shift register into serial information. The sensors fulfill all requirements to the SSI standard for absolute encoders.



Stainless Steel
Cover and Connector



S Connector Style
5 or 6 Pin Micro, 12mm Euro



M Connector Style
6 Pin DIN, Fits MTS D60
7 Pin DIN, Fits MTS D70 (for SSI only)



B Connector Style
8 Pin DIN, Fits Balluff S32



C Connector Style
Integral Cable Assembly



E Connector Style
10 Pin MS Connector,
Fits Gemco 951 & 952 Wiring

Analog Part Numbering

953A/D/SSI VMAX™ LDT

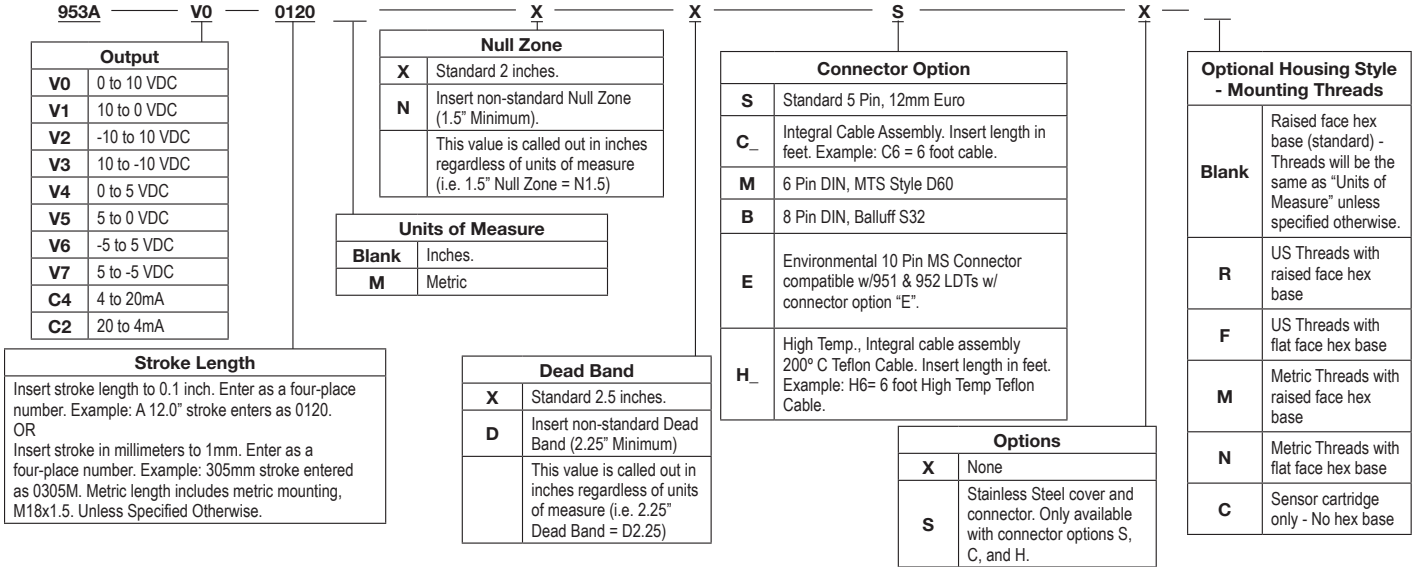

SSI Part Numbering

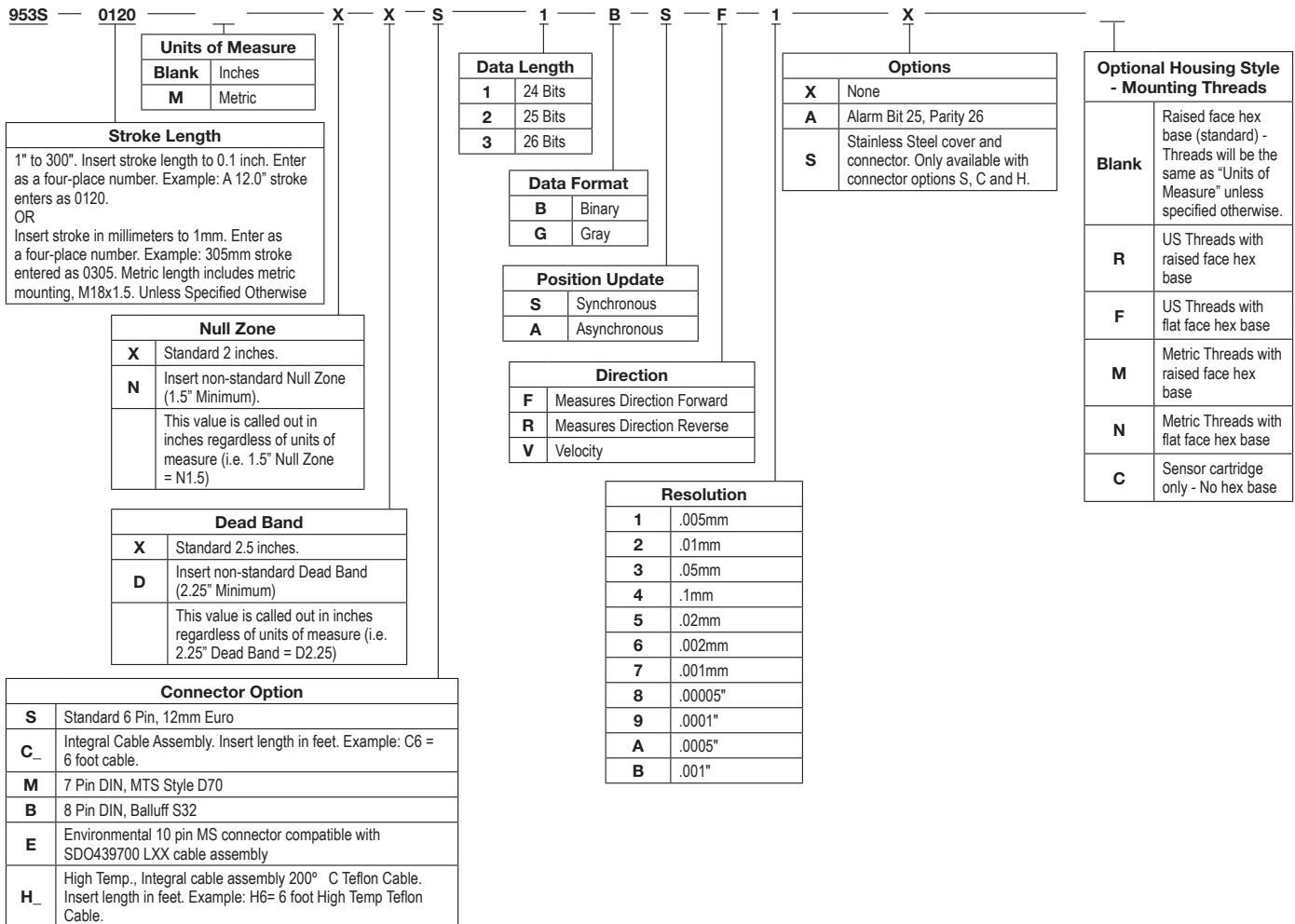

953

953A/D/SSI VMAX™ LDT

Digital, CP and RS Part Numbering

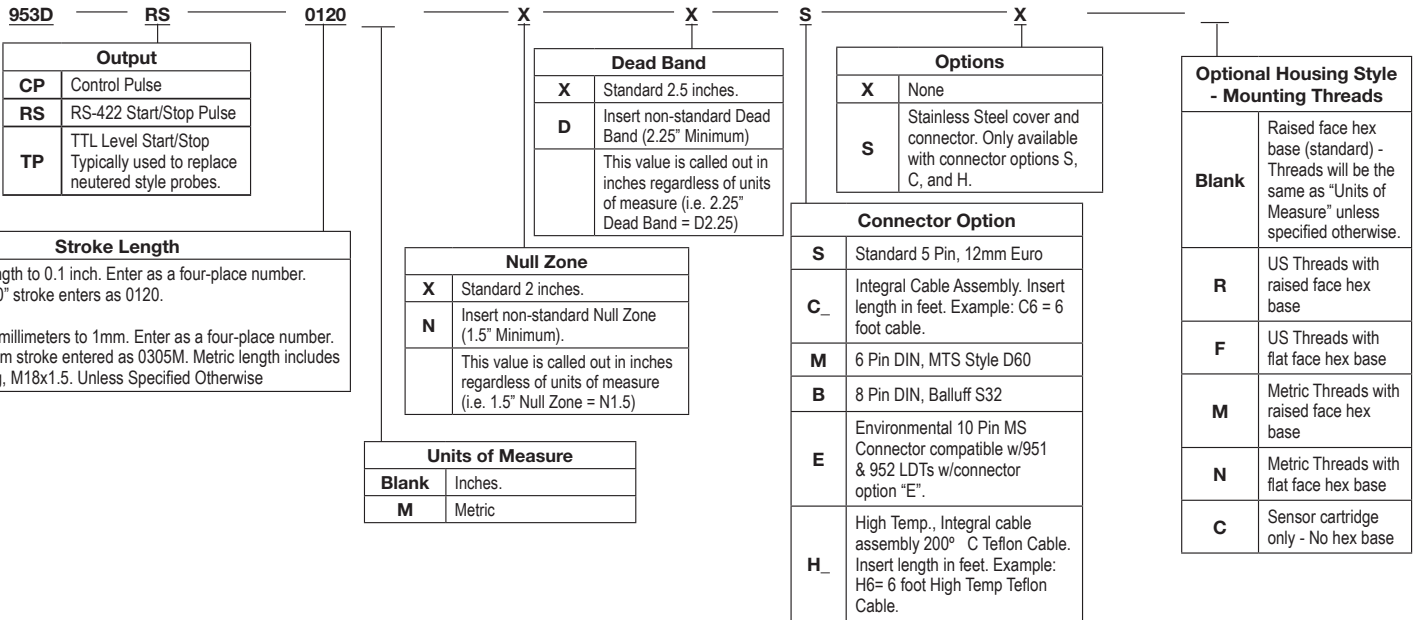

Digital, VP (PWM) Part Numbering

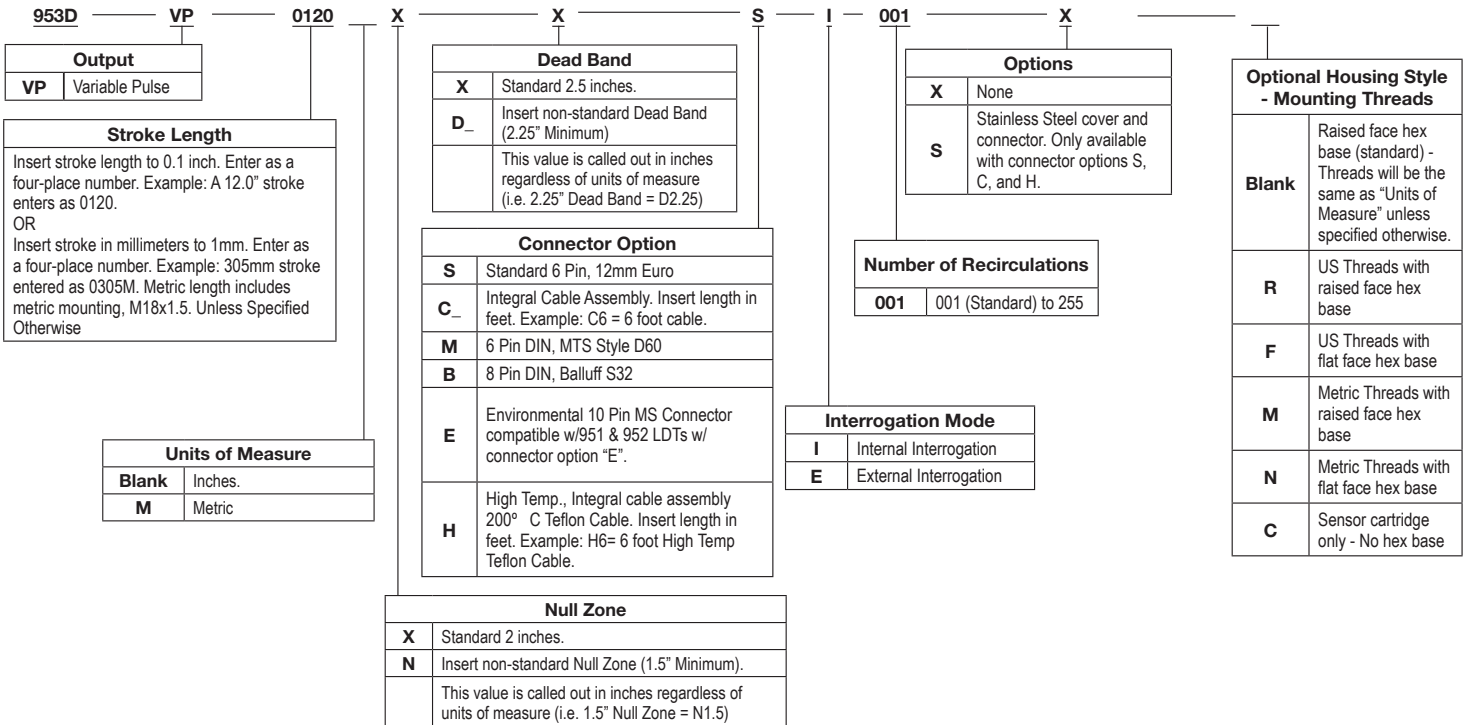

NOTE: Metric LDTs cannot be used with standard 950MD housings. Consult factory.

953A/D/SSI VMAX™ LDT

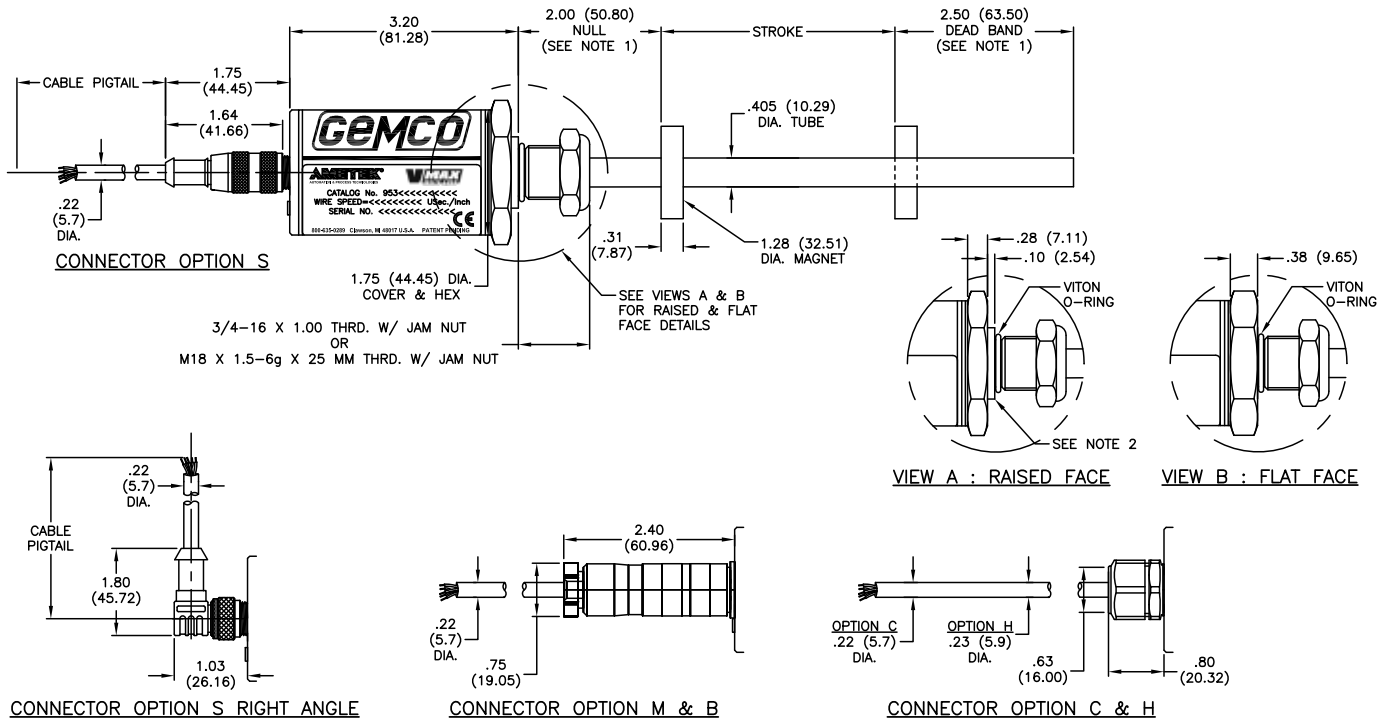

- NOTES:** UNLESS OTHERWISE SPECIFIED
- DRAWING SHOWS STANDARD NULL & DEAD BAND. IF A NON-STANDARD NULL OR DEAD BAND IS SPECIFIED THESE DIMENSIONS MUST BE ADJUSTED ACCORDINGLY.
 - FOR ENGLISH THREAD TYPE, RAISED FACE FEATURE COMPLIES WITH SAE J1926-1.

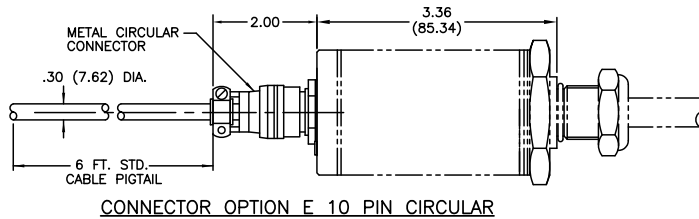

953 LED Output Summary

Output	953A	953D	953SSI
Flashing Red	Flash memory corrupt	Flash memory corrupt	Flash memory corrupt
Flashing Red/Green	EE memory corrupt	EE memory corrupt	EE memory corrupt
Flashing Green	N/A	N/A	N/A
Flashing Yellow	Communication/programming mode	Communication/programming mode	Communication/programming mode
Fast Flashing Yellow	Programming input held asserted	Interrogation input held asserted	Clock input held asserted
Solid Red	No magnet signal detected	No magnet signal detected	No magnet signal detected
Green/Red Blip (1s to 0.12s)	N/A	Max Gain but signal detected and within range	Max Gain but signal detected and within range
Solid Green	Magnet signal detected and within the programmed range	Normal probe operation; magnet signal and interrogation pulse detected	Normal probe operation; magnet signal and SSI clock operational
Solid Yellow	Magnet signal detected outside of the programmed range	No external interrogation pulse detected	No SSI clock pulses detected
Yellow/Red Blip (1s to 0.12s)	N/A	N/A	SSI clock pulses do not match LDT SSI data length
Green/Yellow Blip (1s to 0.12s)	N/A	N/A	LDT data not synchronous with controller (if LDT is programmed for synchronous mode)

953A/D/SSI VMAX™ LDT

Magnets	
Part Number	Description
SD0400800	Standard Four Hole Magnet
SD0480900	Standard Four Hole Magnet, Stainless Steel
SD0403900	Aluminum Split Magnet
SD0411201	Large Split Magnet, Stainless Steel
SD0411200	Large Split Magnet, Standard
SD0410300	Cylinder Magnet, Standard
SD0410301	Cylinder Magnet, Teflon Coated
M0750500	Non-Ferrous Spacer for Split Magnet
M0822400	Non-Ferrous Spacer for Four Hole Magnet

953A Accessories		
Part Number	Description	Use With Connector
949011L6	6 Foot, 5 Pin, Straight, 12mm Euro Cable	S
949011L12	12 Foot, 5 Pin, Straight, 12mm Euro Cable	S
949012L6	6 Foot, 5 Pin, Right Angle, 12mm Euro Cable	S
949012L12	12 Foot, 5 Pin, Right Angle, 12mm Euro Cable	S
SD0553200LXX	6 Pin DIN	M
SD0553300LXX	8 Pin DIN Voltage	B
SD0553400LXX	8 Pin DIN Current	B
SD0400800	Standard 4 Hole Magnet	All

Consult factory for complete accessory offerings. XX = Length in Feet.

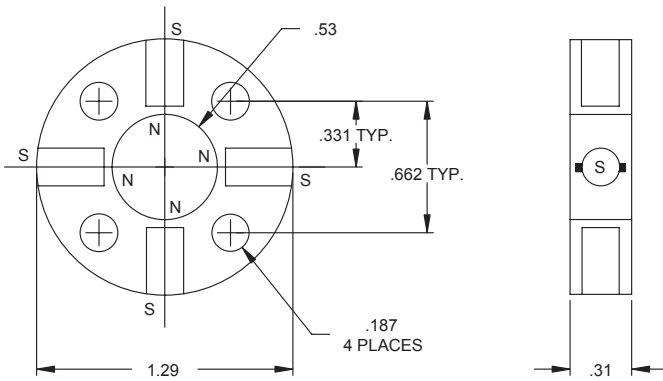

Standard 4 Hole Magnet
Standard P/N: SD0400800
Stainless Steel P/N: SD0480900

953D/953SSI Accessories		
Part Number	Description	Use With Connector
949029L6	6 Foot, 6 Pin, Straight, 12mm Euro Cable	S
949029L12	12 Foot, 6 Pin, Straight, 12mm Euro Cable	S
949030L6	6 Foot, 6 Pin, Right Angle, 12mm Euro Cable	S
949030L12	12 Foot, 6 Pin, Right Angle, 12mm Euro Cable	S
SD0554500LXX	6 Pin DIN (953D)	M
SD0558500LXX	7 Pin DIN (953SSI)	M
SD0554600LXX	8 Pin DIN	B
SD0400800	Standard 4 Hole Magnet	All

Consult factory for complete accessory offerings. XX = Length in Feet.

SSI Cable Length Limits		
Baud Rate	Max. Cable Length	
1 MBd	10 ft.	3 m
400 kBd	160 ft.	50 m
300 kBd	320 ft.	100 m
200 kBd	650 ft.	200 m
100 kBd	1300 ft.	400 m

NOTE: The maximum cable length recommendation is 10 meters or 33 feet. Longer cables are available, but extra care must be taken while handling and installing.

953

955LC BRIK Magnetostrictive LDT In A Low Profile Package

The 955LC BRIK is an accurate, programmable zero and span, non-contact linear position sensor in an economical, low profile package. The sensor utilizes our field proven magnetostrictive technology to give absolute position, repeatable to .01% of the sensing distance. The 955LC is a cost effective linear sensing solution, designed for the OEM market.

The transducer can be ordered with 0-10 VDC or 4-20mA. The unit can easily be re-scaled and changed from a 0-10 VDC to a 10-0 VDC or 4-20mA to a 20-4mA using programming module 955-1412. All units are provided with a standard quick disconnect connector. The streamlined anodized aluminum extrusion houses the sensing element and electronics. The magnet slide moves over the sensing element that determines the position and converts it to a readable output.

The 955LC BRIK is a self-contained unit and does not have a can or head assembly. All of the electronics are incorporated in the transducer which is less than one inch tall. Units can be ordered in span lengths up to 180 inches long in 0.1 inch increments. The magnet slide is designed to move effortlessly along the transducer in guide tracks.

A variety of hardware is available for attaching the magnet slide to the moving portion of the process. The transducer can be mounted vertically or horizontally using mounting feet which slide on the lower part of the extrusion and clamp down when tightened. This packaging provides a compact and easy method of mounting for OEM machine builders.

The 955LC BRIK is designed for OEM applications where economical continuous feedback is necessary. The sensor can be a cost effective replacement to limit switches, proximity sensors, linear potentiometers and LVDT's. Applications include presses, blow molding, injection molding, extrusion, roll positioning, dancer control and many more.

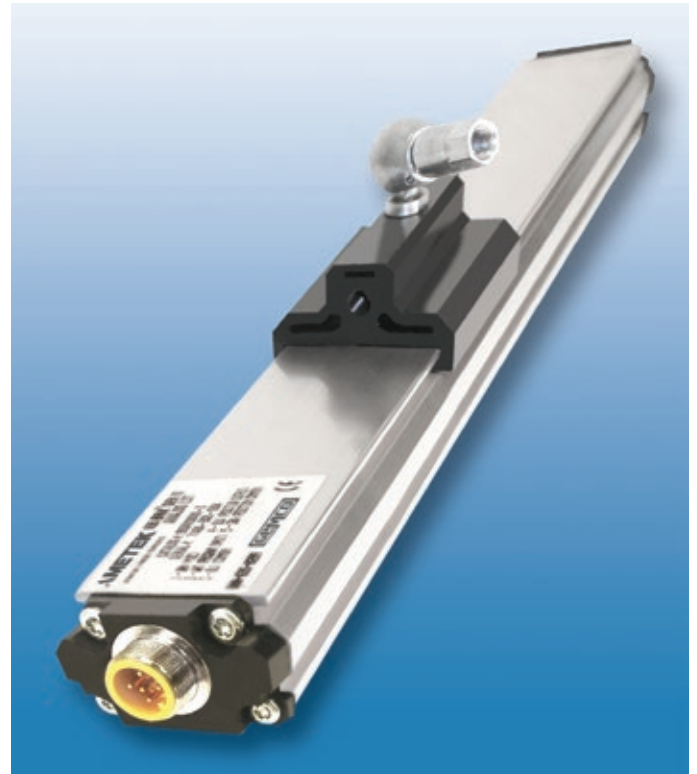

Specifications	
Input Voltage	24 VDC +/- 20%
Current Draw	100mA Max.
Output	0 to 10 VDC 10 to 0 VDC 4 to 20mA 20 to 4mA
Linearity	+/- 0.05% of Stroke or +/- 0.028", Whichever is Greater
Accuracy	0.1% of Full Stroke
Repeatability	+/- 0.01% of Full Stroke or +/- 0.014", Whichever is Greater
Operating Temperature	-20° to 70° C
Span Length	6" to 180"
Null Zone	3.00"
Dead Band	1.50"
Connector	Standard 4 Pin Micro 12mm Euro Connector
Agency Approvals	CE Approved
Enclosure	IP67
Specification may change without notice.	

955LC BRIK

Part Numbering

955LC ——— V0 ——— 0120

Output		Stroke Length	
V0	0 to 10 VDC	Insert stroke to 0.1" as a four-place number, enter 12.0" stroke as 0120; to convert metric strokes, multiply millimeter value by 0.03937 for inch value.	
V1	10 to 0 VDC		
C4	4 to 20mA		
C2	20 to 4mA		

Accessories	
Item	Part Number
Slide Magnet	SD0521800
Floating Magnet	SD0522100
Wide Floating Magnet	SD0551500
Mounting Foot	SD0522000
6 Ft., 4 Pin Cable	949001L6
12 Ft., 4 Pin Cable	949001L12
6 Ft. Cable; Right Angle Connector	949002L6
12 Ft. Cable; Right Angle Connector	949002L12
Program Module	955-1412

Wiring Diagram

Use Euro Connector (micro 12 mm single keyway) cordsets, available from most connector manufacturers or purchased from Ametek. Install according to the following diagrams:

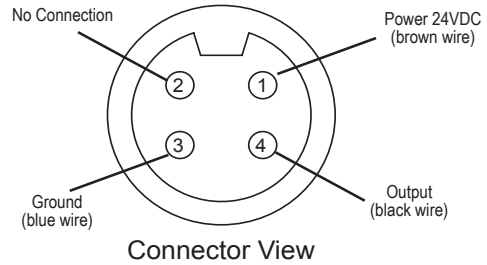

Note: The North side of a floating magnet will face the LDT's sensing surface.

Sensing Surface

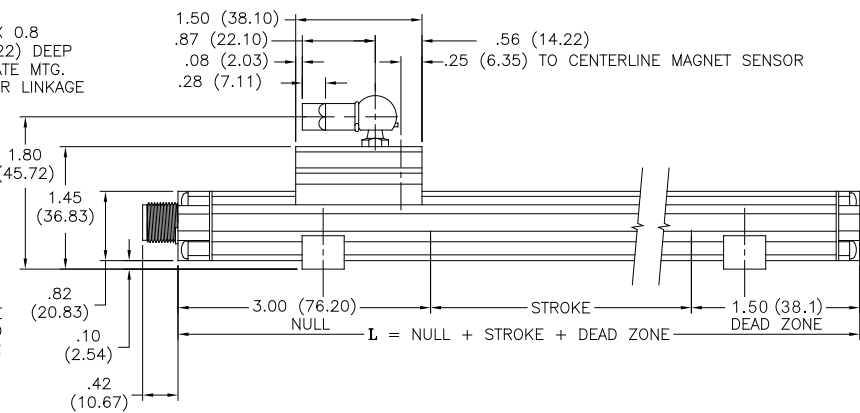
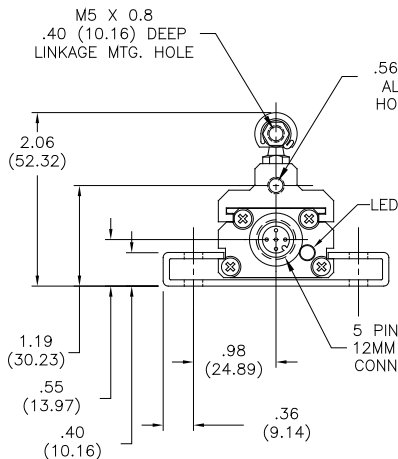
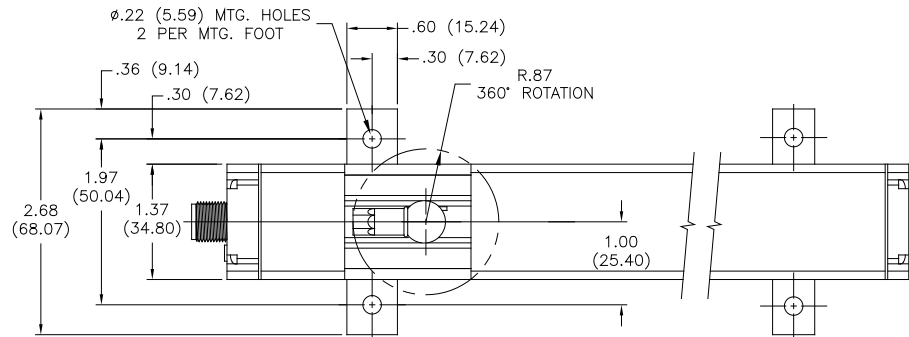
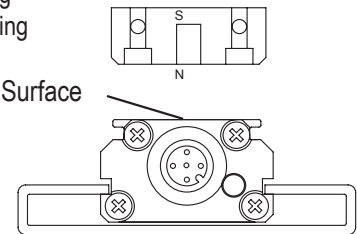

955

955 eBRIK™ High Resolution Magnetostrictive LDT In A Low Profile Package

The 955 eBrik™ is an accurate, programmable zero and span, auto-tuning, non-contact linear position sensor in an economical, low-profile package. The sensor utilizes our field-proven Magnetostrictive technology to provide absolute position, repeatable to .001% of the sensing distance. The 955 eBrik™ is a cost effective linear sensing solution.

The streamlined anodized aluminum extrusion houses the sensing element and electronics. The magnet moves over the sensing element that determines the position and converts it to a readable output. The 955 eBrik™ is a self-contained unit and does not have a “can” or head assembly. All of the electronics are incorporated in the transducer, which is less than one inch tall.

Units can be ordered in span lengths up to 72 inches long in 1 inch increments. The slide magnet is designed to move effortlessly along the transducer in guide tracks, or a floating magnet assembly can be positioned above the unit. A variety of hardware is available for attaching the magnet slide to the moving portion of the process. The transducer can be ordered with 0 to 10 VDC or 4 to 20 mA output.

All units are provided with our standard 5 pin 12mm Euro Micro connector, mounting feet and magnet assembly. Mating cables are sold in various lengths and must be ordered separately.

The 955 eBrik™ has a few truly unique features. One feature is the LDT’s auto-tuning capability, the ability to sense the distance between the magnet and the sensing surface and adjust its signal strength accordingly. As a bonus feature, the 955 eBrik™ offers Programmability, the ability to rescale the Zero and Span positions or invert the positions in the field. This is an optional feature and must be called out at time of order under the “Options” field. All units come fully programmed from the factory, are 100% absolute, and do not require reprogramming unless desired. There is a unique diagnostic that is built into the analog output on every unit. If there is a loss of magnet, or if the magnet assembly moves beyond the programmed range, the analog output will transmit a fault voltage or current, warning the host controller that it is out of range.

The transducer can be mounted vertically or horizontally using our mounting feet which slide on the lower part of the extrusion and clamp down when tightened. This packaging provides a compact and easy method of mounting for machine builders.

The 955 eBrik™ is designed for applications where economical continuous feedback is necessary. The sensor can be a cost effective replacement to linear potentiometers, limit and proximity sensors. Applications include presses, blow molding, injection molding, extruding, roll positioning, tire press, and many more.

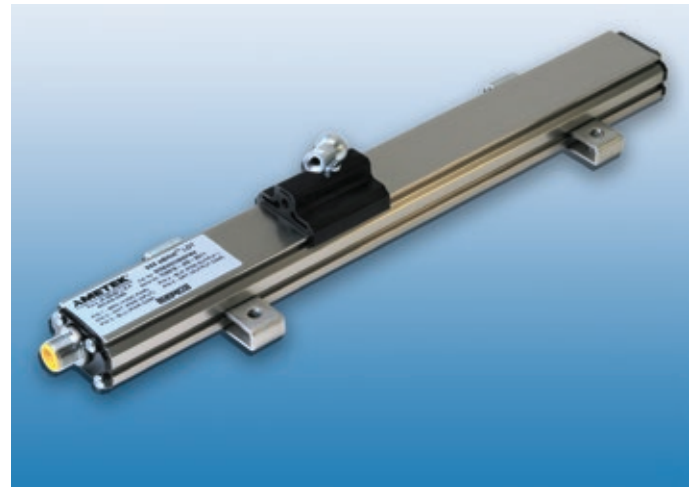

Specifications	
Input Voltage	24 VDC +/- 20%
Current Draw	1.1w (44 mA typical)
Output	0 to 10 VDC 10 to 0 VDC 4 to 20 mA 20 to 4 mA
Non-Linearity	Less than +/- 0.03% of stroke, or +/- 0.013" whichever is greater
Resolution	16 Bit (1 part in 65535)
Update Time	1 ms
Repeatability	.001%
Operating Temperature	-40° to 85° C
Span Length	1" to 72"
Null Zone	2.75"
Dead Zone	2.75"
Connectors	12mm Micro 5 Pin
Enclosure	IP67
Approvals	CE
Specifications are subject to change without notice.	

955

955 eBRIK™

Part Numbering

955e	V0	0120	E	FM	X
955 eBrik™	Output Type V0 = 0 to 10 V1 = 10 to 0 C2 = 20 to 4mA C4 = 4 to 20mA	Stroke Length Insert stroke length to 1 inch or 25mm. Enter as a four-place number. Example: A 12.0" stroke is entered as 0120 (E) or 100mm is entered as 0100 (M).	Units of Measure E = English US inches M = Metric	Magnet Type FM = Floating Magnet (Standard) SM = Slide Magnet Top Swivel SF = Slide Magnet Front Swivel X = No Magnet	Options X = No Options P = Programmable Zero & Span

Dimension Drawing

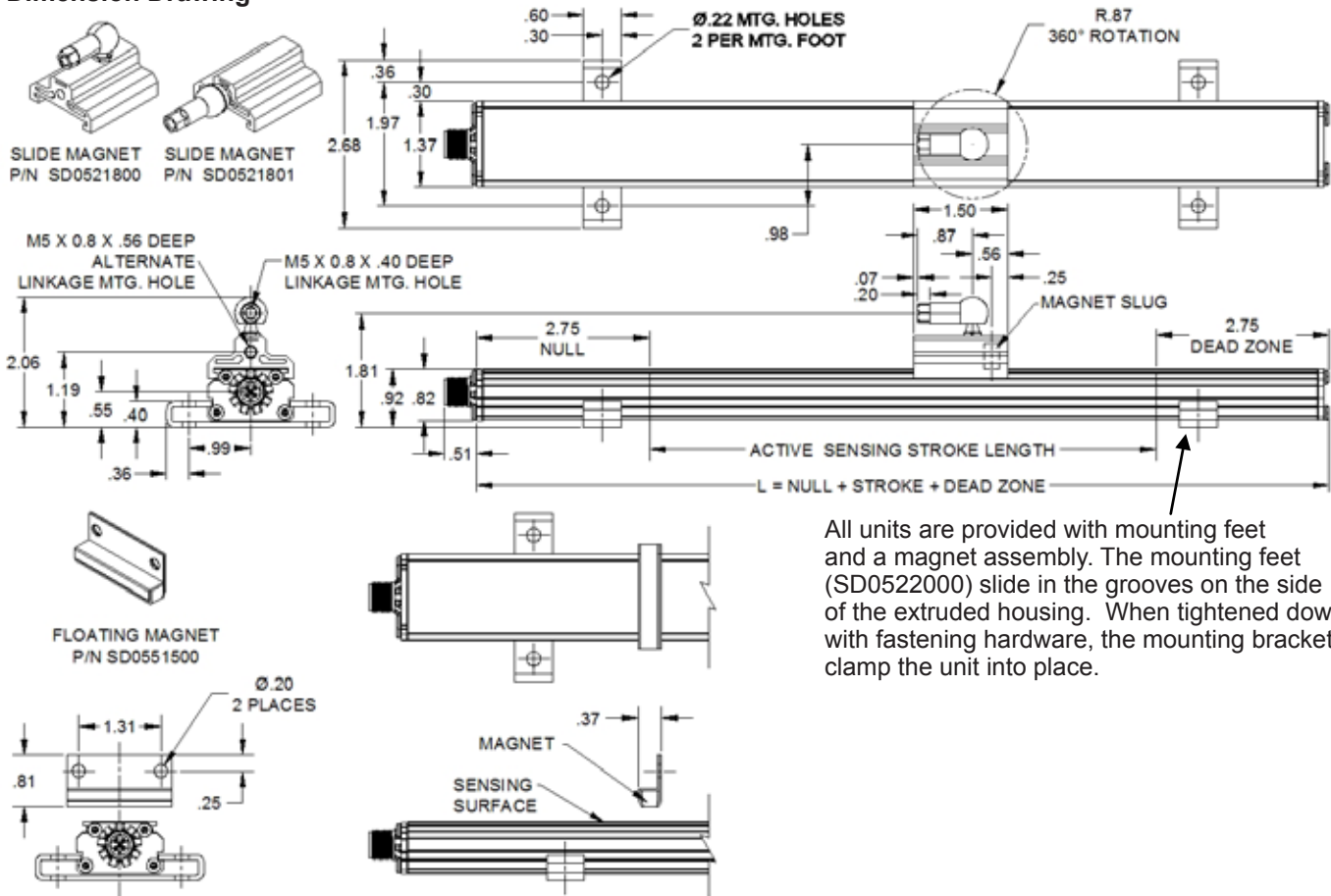

All units are provided with mounting feet and a magnet assembly. The mounting feet (SD0522000) slide in the grooves on the side of the extruded housing. When tightened down with fastening hardware, the mounting brackets clamp the unit into place.

Accessories

Item	Part Number
Slide Magnet	SD0521800
Slide Magnet Side Adapter	SD0521801
Large Float Magnet	SD0551500
Mounting Foot	SD0522000
6 Ft. Cable - Straight	949019L6
12 Ft. Cable - Straight	949019L12
6 Ft. Cable - Right Angle	949020L6
12 Ft. Cable - Right Angle	949020L12
Control Arm	955ARMXX (X = Inches)
Rod Ends	04-570252

Wiring Diagram

KEY LOCATION LDT Connector End View	PIN Number	Function	Color
	1	+VDC POWER SUPPLY	BROWN
2	PROGRAM*	WHITE	
3	POWER SUPPLY COMMON	BLUE	
4	ANALOG OUT	BLACK	
5	ANALOG COMMON	GRAY	

*Optional feature must be specified in the part number at time of order.

955S Smart BRIK Magnetostrictive LDT In A Low Profile Package

The 955S Smart BRIK is an accurate, programmable zero and span, auto-tuning, non-contact linear position sensor in an economical, low profile package. The sensor utilizes our field proven magnetostrictive technology to give absolute position, repeatable to .01% of the sensing distance. The 955S Smart BRIK is a cost effective linear sensing solution.

The streamlined anodized aluminum extrusion houses the sensing element and electronics. The magnet slide moves over the sensing element that determines the position and converts it to a readable output. The 955S Smart BRIK is a self-contained unit and does not have a can or head assembly. All of the electronics are incorporated in the transducer which is less than one inch tall. Units can be ordered in span lengths up to 180 inches long in 0.1 inch increments. The magnet slide is designed to move effortlessly along the transducer in guide tracks or a floating magnet assembly can be positioned above the unit.

A variety of hardware is available for attaching the magnet slide to the moving portion of the process. The transducer can be mounted vertically or horizontally using our mounting feet which slide on the lower part of the extrusion and clamp down when tightened. This packaging provides a compact and easy method of mounting for machine builders.

The transducer can be ordered with 0 to 10 VDC, 4 to 20mA, or -10 to 10 VDC output. All units are provided with a standard quick disconnect connector. A unique feature is the diagnostic LED that remains green when a good magnet signal is present and when in the active programmed area. The LED turns yellow when the magnet is out of the programmed active range but still within the active stroke area. The LED turns red when there is no magnet present or the magnet assembly is out of the sensing area.

The 955S Smart BRIK is designed for applications where economical continuous feedback is necessary. The sensor can be a cost effective replacement to limit and proximity sensors and linear potentiometers. Applications include presses, blow molding, injection molding, extruding, roll positioning and many more.

As an added benefit, the 955S is FM approved for Class I, Div 2, Groups A, B, C, D applications when installed and wired per drawing E0241100 as shown in the manual. If your application does not require FM Class I, Div 2 approval, wire the 955S using a standard 4 pin Euro cordset from Ametek or others.

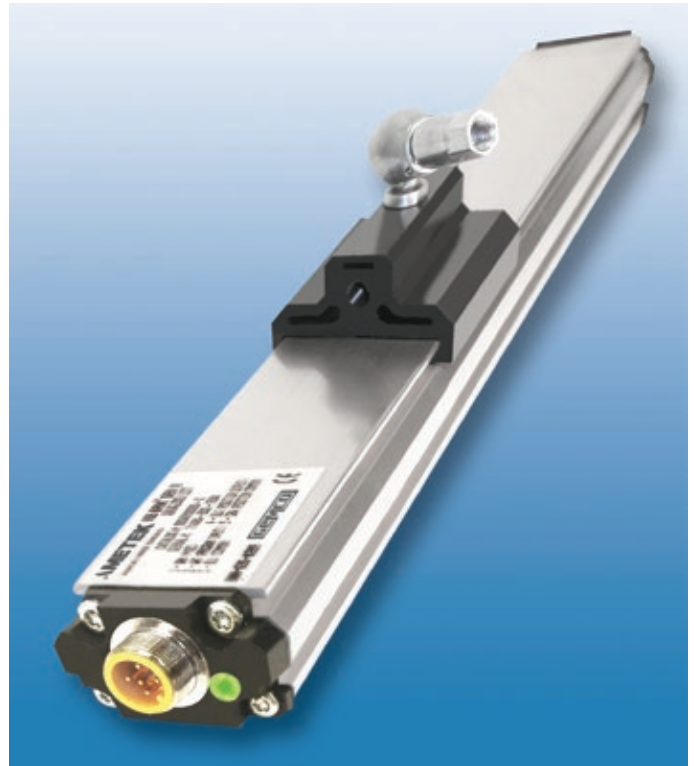

Specifications	
Input Voltage	10 to 30 VDC
Current Draw	100mA Max.
Output	V0 = 0 to 10 VDC V1 = 10 to 0 VDC V2 = -10 to 10 VDC V3 = 10 to 10 VDC V4 = 0 to 5 VDC V5 = 5 to 0 VDC V6 = -5 to 5 VDC V7 = 5 to -5 VDC C4 = 4 to 20mA C2 = 20 to 4mA
Linearity	+/- 0.05% of Full Stroke
Accuracy	+/- 0.1% of Full Stroke
Repeatability	+/- 0.01% of Full Stroke
Operating Temperature	-40° to 158° F (-40° to 70° C)
Span Length	4" to 180"
Null Zone	3"
Dead Band	1.5"
Connectors	12mm Micro 4 Pin
Enclosure	IP67, IP68 Optional
Approvals	CE, FM Class I, Div 2
Specifications are subject to change without notice.	

955S Smart BRIK

Dimension Drawing

Note: The North side of a floating magnet will face the LDT's sensing surface.

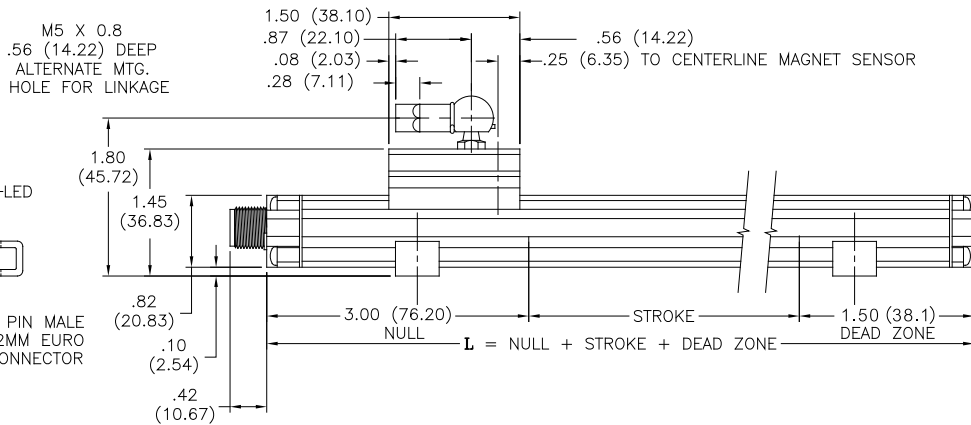
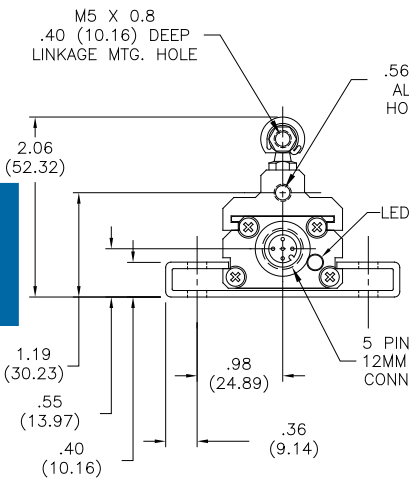
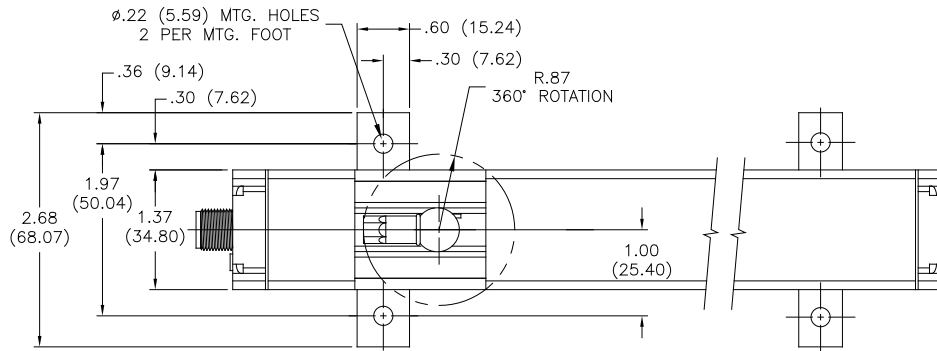
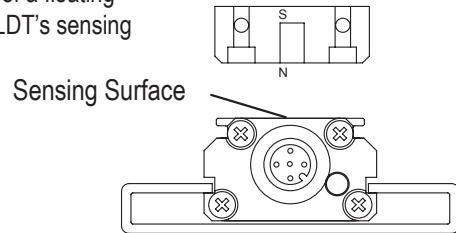

Wiring Diagram

Use Euro Connector (micro 12 mm single keyway) cordsets, available from most connector manufacturers or purchased from Ametek. Install according to the following diagram:

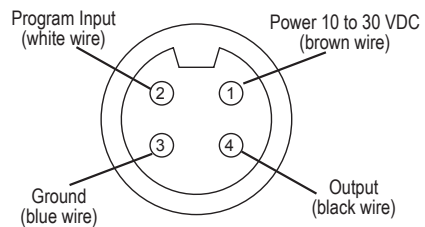

Connector View

955S Smart BRIK

Part Numbering

955S	V0	0120			
Output		Stroke Length			
V0	0 to 10 VDC	Insert stroke to 0.1" as a four-place number, enter 12.0" stroke as 0120. OR Insert stroke in millimeters to 1mm. Enter as a four-place number followed by 'M'. Example: 305mm stroke entered as 0305M.			
V1	10 to 0 VDC				
V2	-10 to 10 VDC				
V3	10 to -10 VDC				
V4	0 to 5 VDC				
V5	5 to 0 VDC				
V6	-5 to 5 VDC				
V7	5 to -5 VDC				
C4	4 to 20mA				
C2	20 to 4mA				
				Options	
				Leave blank for no options.	
		E	Wet environment, electronics sealed to IP68 rating		

Accessories	
Item	Part Number
Slide Magnet	SD0521800
Slide Magnet Side Adapter	SD0521801
Floating Magnet	SD0522100
Wide Floating Magnet	SD0551500
Mounting Foot	SD0522000
6 Ft., 4 Pin Cable	949001L6
12 Ft., 4 Pin Cable	949001L12
6 Ft., 4 Pin Cable, Right Angle Connector	949002L6
12 Ft., 4 Pin Cable, Right Angle Connector	949002L12
Control Arm	955ARMXX (X = Inches)
In-Line Programming Unit	955-1409
Plastic Rod End	04-570252
FM Accessories	
6 Ft., 4 Pin Straight Cable	949024L6
12 Ft., 4 Pin Straight Cable	949024L12
Connector Lock	04-521570
NOTE: FM approved cordset and connector lock must be used and installed per drawing E0241100 when installing the 955S in Class I, Div 2, Group A, B, C, D applications.	



955

Gemco 955A BRIK Gen III

The 955A BRIK Gen III is an accurate programmable, auto-tuning, non-contact, linear displacement transducer in an economical, low profile package. The transducer utilizes our field proven magnetostrictive technology to give absolute position, repeatable to .006% of the programmable sensing distance.

The streamlined anodized aluminum extrusion houses the sensing element and electronics. The magnet moves over the sensing element that determines the position and converts it to an analog output. It can be ordered with a 0 to 10 VDC or 4 to 20mA output.

The 955A BRIK Gen III has a few truly unique features. The first one is the LDT's auto-tuning capability, the ability to sense a magnet other than the standard slide magnet and adjust its signal strength accordingly. Another feature is the analog output is programmable over the entire active stroke length. The active stroke area of the LDT lies between the Null and Dead zones. There is a diagnostic LED located at the connector end of the probe that remains green while a good magnet signal is present and when the magnet is in the programmed stroke area. The LED turns yellow when the magnet is out of the programmed active range, but still within the active stroke area. The LED turns red and the output goes to 0 volts on voltage output units, or 4mA on current output units when there is no magnet present or when the magnet is out of the sensing area.

The unit can easily be changed in the field from a 0 - 10 VDC to a 10 - 0 VDC or 4 - 20mA to a 20 - 4mA . As an added feature, the optional differential analog output allows the distance between two magnets to be measured.

The 955A BRIK is designed for applications where economical continuous feedback is necessary. The sensor can be a cost effective replacement to limit switches, proximity sensors, linear potentiometers and LVDT's. Applications include presses, blow molding, injection molding, extrusion, roll positioning, dancer control and many more.

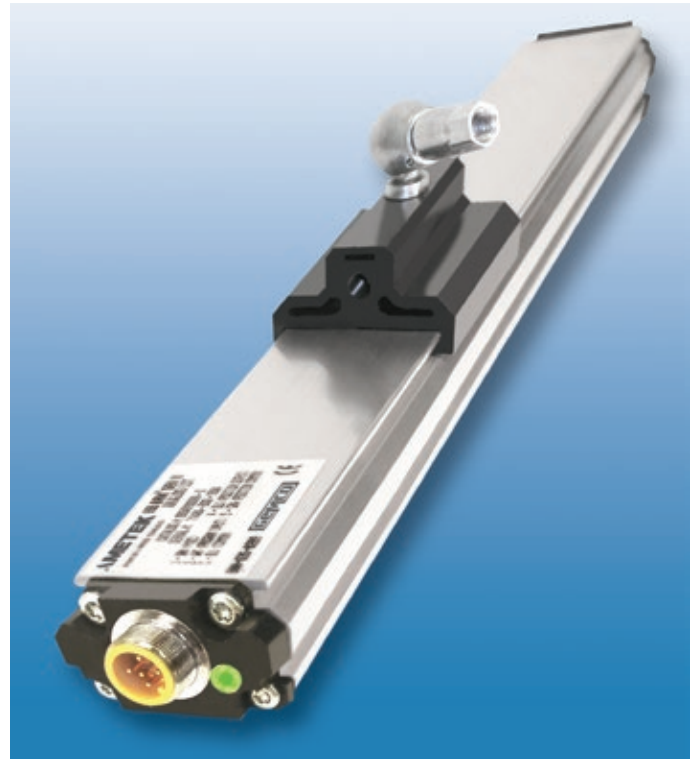

Specifications	
Input Voltage	13.5 to 30 VDC
Current Draw	2.5 Watts Maximum, 120mA @ 15 VDC Typical
Output	0 to 10 VDC, 10 to 0 VDC, 4 to 20mA, 20 to 4mA
Resolution Internal Analog Output	0.001" 16 Bit (1 part in 65,535)
Linearity	+/- 0.05% of Stroke
Repeatability	+/- 0.006% of Full Stroke
Hysteresis	+/- 0.02% of Full Scale
Update 50" or less 51" to 100" 101" to 150" 151" to 180"	1ms (Stroke Lengths 5" to 50") 2ms (Stroke Lengths 51" to 100") 3ms (Stroke Lengths 101" to 150") 4ms (Stroke Lengths 151" to 180")
Operating Temperature	-20° to 70° C
Span Length	5" to 180"
Null Zone	3.00"
Dead Band	2.00"
LED	Green = Power is applied and magnet is present Red = Fault, magnet is in the Dead Band or lost Yellow = Out of the active programmed range
Connector	Standard 5 Pin Micro 12mm Euro Connector
Approvals	CE
Enclosure	IP67, IP68 Optional
Specifications are subject to change without notice. Specifications are based on a typical 36" LDT.	

955

955A BRIK Gen III Part Numbering

955A		V0	0120	X
Output		Stroke Length		
V0	0 to 10 VDC	Insert stroke to 0.1" as a four-place number, enter 12.0" stroke as 0120. OR Insert stroke in millimeters to 1mm. Enter as a four-place number followed by 'M'. Example: 305mm stroke entered as 0305M.		
V1	10 to 0 VDC			
C4	4 to 20mA			
C2	20 to 4mA			
D0	Differential 0 to 10 VDC*			
D1	Differential 4 to 20mA*	Options		
		X	No options.	
		E	Wet environment, electronics sealed to IP68 rating	

*Analog differential output is the difference between two magnets. Minimum distance is 2.5".

Wiring Diagram

Use Euro Connector (micro 12 mm single keyway) cordsets, available from most connector manufacturers or purchased from Ametek. Install according to the following diagram:

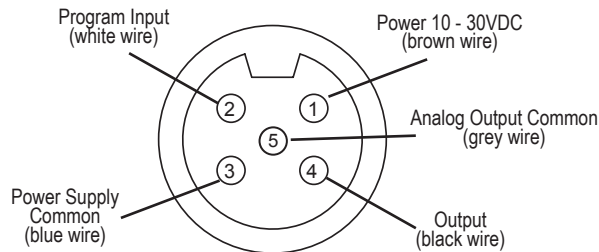

Accessories

Item	Part Number
Slide Magnet	SD0521800
Floating Magnet	SD0522100
Wide Floating Magnet	SD0551500
Mounting Foot	SD0522000
6 Ft., 5 Pin Cable	949019L6
12 Ft., 5 Pin Cable	949019L12
6 Ft., 5 Pin Cable; Right Angle Connector	949020L6
12 Ft., 5 Pin Cable; Right Angle Connector	949020L12

Gemco 955D Digital BRIK Gen III

The 955D Digital BRIK Gen III is an accurate programmable, auto-tuning, non-contact, linear displacement transducer in an economical, low profile package. The transducer utilizes our field proven magnetostrictive technology to give absolute position, repeatable to .006% of the programmable sensing distance.

The streamlined anodized aluminum extrusion houses the sensing element and electronics. The magnet moves over the sensing element that determines the position and converts it to either a control pulse, variable pulse or RS422 Start/Stop digital output. The 955D is compatible with PLC Interface Cards like our 2120L1 module and 1746 LTD Interface Card.

The 955D BRIK Gen III has some truly unique features. The first one is the LDT's auto-tuning capability, the ability to sense a magnet other than the standard slide magnet and adjust its signal strength accordingly.

There is a diagnostic LED located at the connector end of the probe that remains green while a good magnet signal is present and when the magnet is in the programmed stroke area. The LED turns yellow if no interrogation signal is detected. The LED turns red when there is no magnet present or when the magnet is out of the sensing area.

The 955D BRIK is designed for applications where economical continuous feedback is necessary. The sensor can be a cost effective replacement to limit switches, proximity sensors, linear potentiometers and LVDT's. Applications include presses, blow molding, injection molding, extrusion, roll positioning, dancer control and many more.

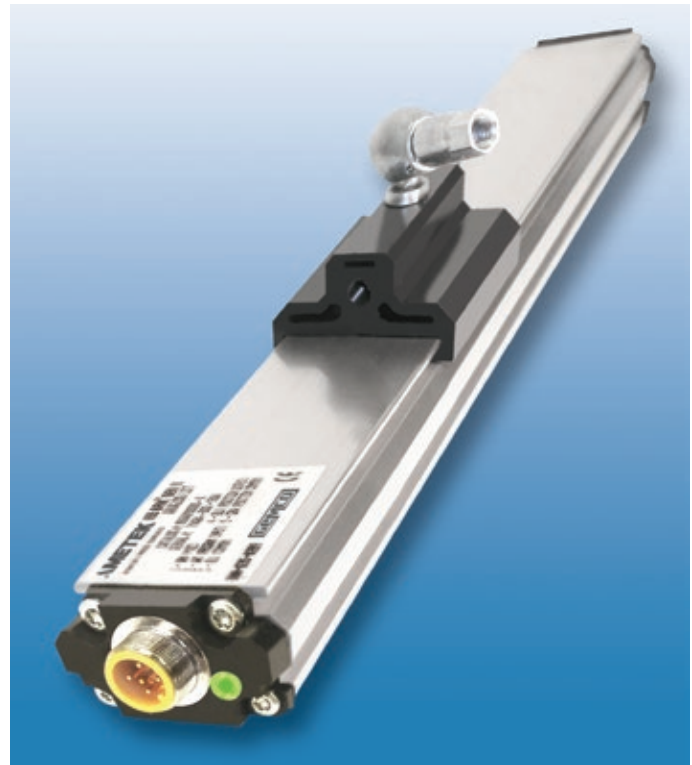

Specifications	
Input Voltage	13.5 to 30 VDC
Current Draw	2.5 Watts Maximum, 120mA @ 15 VDC Typical
Output	Control Pulse, Variable Pulse, Stop/Start
Resolution	Controller Dependent
Linearity	+/- 0.05% of Stroke
Repeatibility	+/- 0.006% of Full Stroke
Hysteresis	+/- 0.02% of Full Scale
Update	Controller Dependent
Operating Temperature	-20° to 70° C
Span Length	5" to 180"
Null Zone	3.00"
Dead Band	2.00"
LED	Green = Power is applied and magnet is present Red = Fault, magnet is in the Dead Band or lost Yellow = No interrogation signal
Connector	Standard 6 Pin Micro 12mm Euro Connector
Approvals	CE
Enclosure	IP67, IP68 Optional
Specifications are subject to change without notice. Specifications are based on a typical 36" LDT.	

955

955D BRIK Gen III

Part Numbering

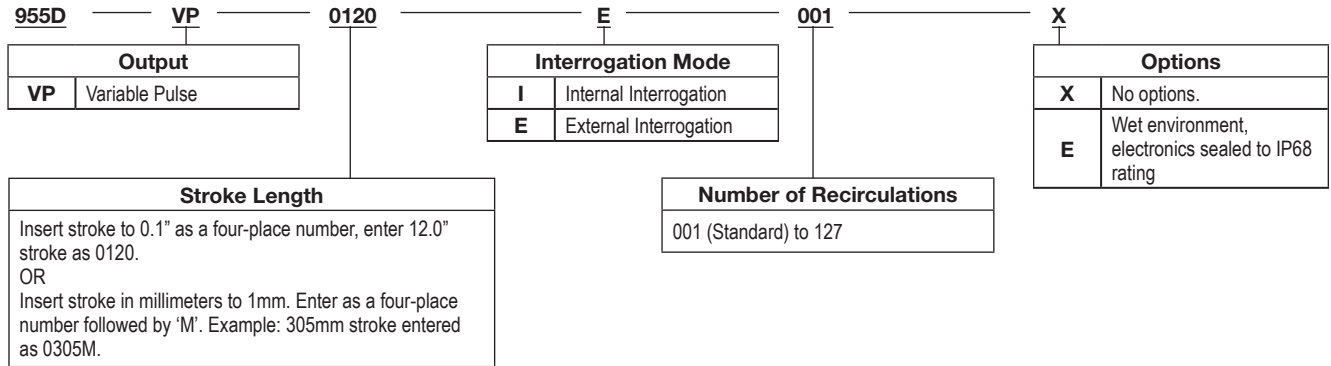
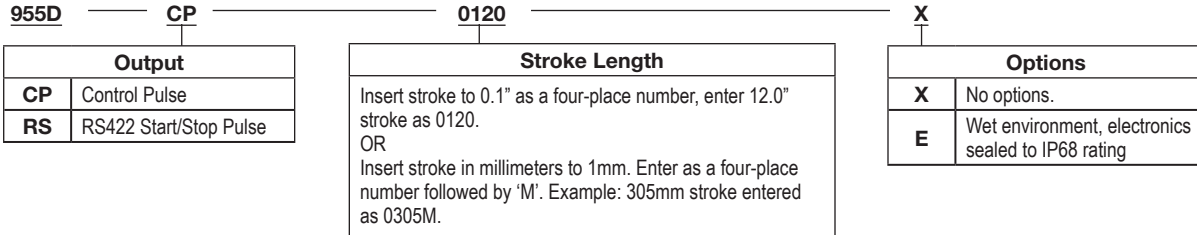

Accessories	
Item	Part Number
Slide Magnet	SD0521800
Floating Magnet	SD0522100
Wide Floating Magnet	SD0551500
Mounting Foot	SD0522000
6 Ft., 6 Pin Cable	949021L6
12 Ft., 6 Pin Cable	949021L12
6 Ft., 6 Pin Cable; Right Angle Connector	949022L6
12 Ft., 6 Pin Cable; Right Angle Connector	949022L12

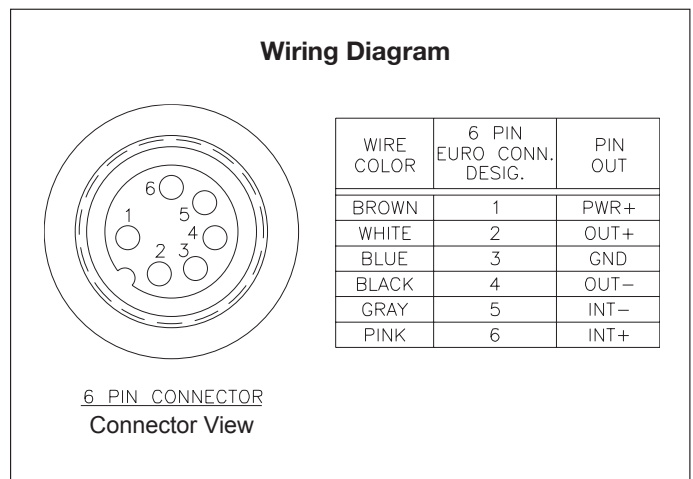

955DQ BRIK Gen III Magnetostrictive LDT In A Low Profile Package

The 955DQ BRIK is an accurate, auto-tuning, non-contact linear displacement transducer in an economical, low profile package with direct quadrature output.

This new method of interfacing magnetostrictive transducers offers an interface as common as analog but with the speed and accuracy of pulsed type signaling. The Gemco 955DQ linear transducer provides quadrature output directly from the transducer to the controller. The output from the transducer can be wired directly to any incremental encoder input card, without the need for a special converter module or a PLC interface card designed specifically for use with a pulsed output magnetostrictive transducer.

The streamlined anodized aluminum extrusion houses the sensing element and electronics. The BRIK with quadrature output is a self-contained unit and does not have a can or head assembly. All of the electronics are incorporated in the transducer which is less than one inch deep. The magnet slide is designed to move effortlessly along the transducer in a guide track or a floating magnet assembly can be positioned above the unit.

The 955DQ BRIK has a few truly unique features. First, the LDT has auto-tuning capability. This is the ability to sense a magnet other than the standard slide magnet and adjust its signal strength accordingly. Another feature is a diagnostic LED located at the connector end of the probe that remains green when a good magnet signal is present and power is normal. The LED turns red when there is no magnet present or the magnet assembly is out of the sensing area.

The 955DQ LDT can be ordered with 1-9999 cycles per inch of output resolution in lengths of 5 to 180 inches. The transducer features an input to re-zero the probe “on-the-fly”. Another unique feature is the “burst” mode. An input on the transducer triggers a data transfer of all the incremental position data relative to the customer's set zero position. This can be used to achieve absolute position updates when power is restored to the system, eliminating the time consuming need to “re-home” the machine.

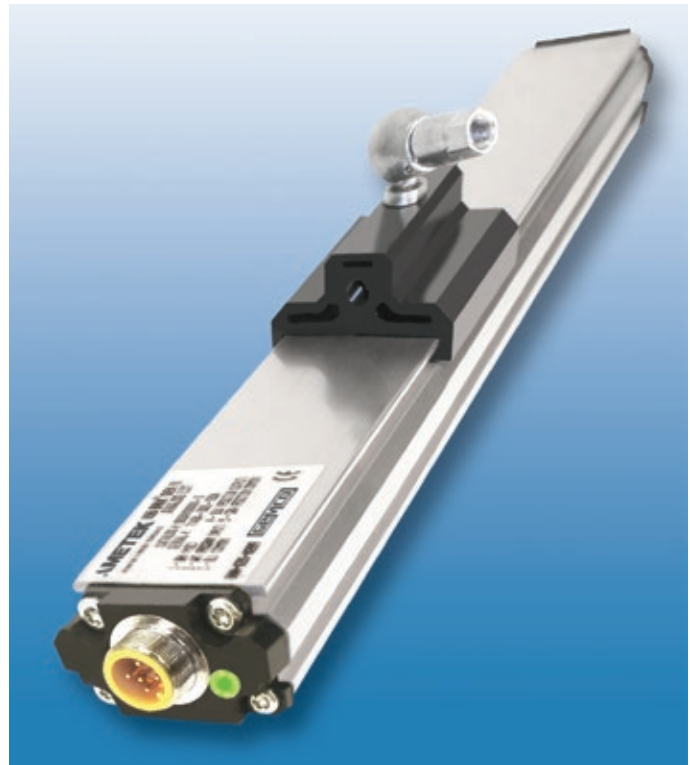

Specifications	
Input Voltage	13.5 to 30 VDC
Current Draw	2.5 Watts Maximum, 120mA @ 15 VDC Typical
Output	Quadrature Output A+, A-, B+, B-, Z+, Z- Line Drivers: 5V or Input Power
Resolution	0.001"
Linearity	+/- 0.05% of Stroke
Repeatability	+/- 0.006% of Full Stroke
Hysteresis	+/- 0.02% of Full Scale
Update	1ms (Stroke Lengths 5" to 50") 2ms (Stroke Lengths 51" to 100") 3ms (Stroke Lengths 101" to 150") 4ms (Stroke Lengths 151" to 180")
Operating Temperature	-20° to 70° C
Span Length	5" to 180"
Null Zone	3.00"
Dead Band	2.00"
LED	Green = Power is applied and magnet is present Red = Fault, magnet is in the Dead Band or lost
Connector	Standard 12 Pin Micro (Option E) 12mm Euro Connector or 10 Pin HRS (Option H)
Approvals	CE
Enclosure	IP67, IP68 Optional (Connector Option E Only)
Specifications are subject to change without notice. Specifications are based on a typical 36" LDT.	

955DQ BRIK Gen III Part Numbering

955DQ — 0120 — E — 1000 — E — F7 — X1 — N — D — X

955DQ Quadrature

Stroke Length

Insert stroke to 0.1" as a four-place number, enter 12.0" stroke as 0120.
OR
Insert stroke in millimeters to 1mm. Enter as a four-place number followed by 'M'. Example: 305mm stroke entered as 0305M.

Connector Option

H	HRS environmental connector
E	Euro 12 Pin, 12mm connector

Output Resolution

Cycles per inch, maximum internal resolution is 0.001 inches 1000 standard (available range is 0001 through 9999)

Quadrature Cycle Output Frequency Range

A1	1 kHz
A2	2 kHz
A3	5 kHz
F1	10 kHz
F2	25 kHz
F3	50 kHz
F4	75 kHz
F5	100 kHz
F6	150 kHz
F7	250 kHz
F8	500 kHz
F9	1 MHz

Output Mode

X1	X1 quadrature, consult factory for other output modes
D1	Dual magnet, difference between magnets

Options

X	None
E	Wet environment, electronics sealed to IP68 rating, connector option E only

Output Drivers

D	Differential RS422 line driver, TTL compatible
L	Differential line driver 10 to 30 VDC, V _{out} = V _{in} (LDT Power) -1 Volt

Input

E	Sinking (typically used with sourcing output type)
C	Sourcing (typically used with sinking output type)
T	TTL Level

Zero Offset Storage

V	Volatile (non retentive)
N	Nonvolatile (retentive, 100,000 storage cycles maximum)

Accessories	
Item	Part Number
Slide Magnet	SD0521800
Floating Magnet	SD0522100
Wide Floating Magnet	SD0551500
Mounting Foot	SD0522000
6 Ft. Cable (Option H)	SD0527700L6 - Obsolete, consult factory
12 Ft. Cable (Option H)	SD0527700L12 - Obsolete, consult factory
25 Ft. Cable (Option H)	SD0527700L25 - Obsolete, consult factory
6 Ft. 12 Pin (Option E Connector)	949023L6
12 Ft. 12 Pin (Option E Connector)	949023L12
Control Arm	955ARMXX (X = Length in Inches)
Plastic Rod End	04-570252

For non-standard lengths, consult factory.

Wiring Diagram (Connector Option H)

10 PIN HIROSE CONNECTOR VIEW

WIRE COLOR	10 PIN CONN. DESIG.
BLACK	1
RED	2
GREEN	3
BROWN	4
BLUE	5
ORANGE	6
YELLOW	7
WHITE	8
VIOLET	9
GRAY	10

Wiring Diagram (Connector Option E)

12 PIN CONNECTOR VIEW

WIRE COLOR	12 PIN CONN. DESIG.	PIN OUT
WHITE	1	B+
BROWN	2	PWR+
GREEN	3	Z+
YELLOW	4	Z-
GRAY	5	A+
PINK	6	A-
BLUE	7	GND
RED	8	BURST
ORANGE	9	ZERO
TAN	10	B-
NC	11	-
NC	12	-

955

955A/D/DQ BRIK Gen III

Dimension Drawing

Note: The North side of a floating magnet will face the LDT's sensing surface.

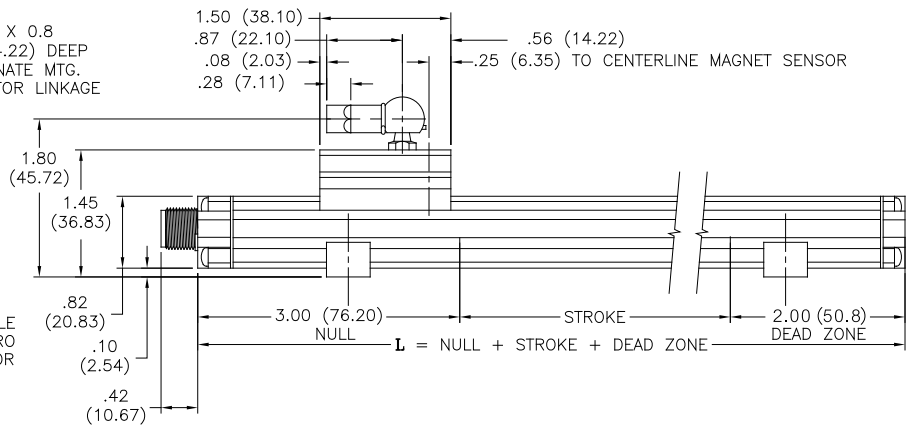
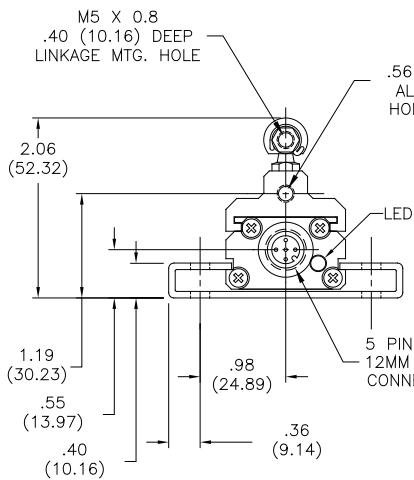
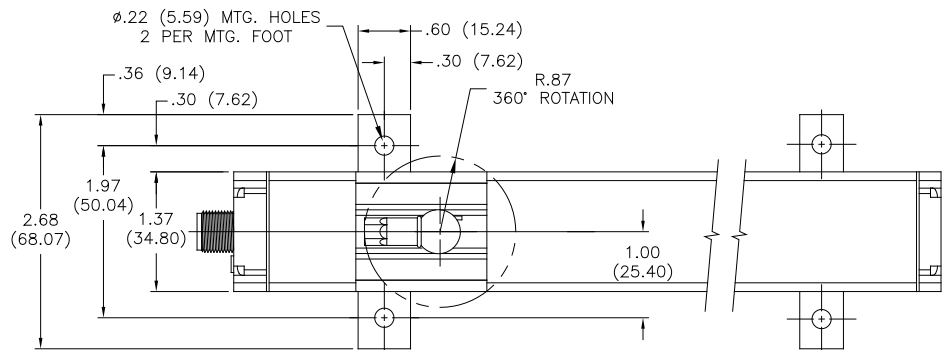
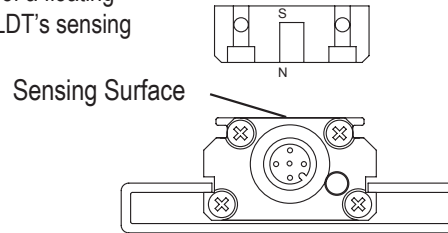

955

955C BRIK for Pneumatic Cylinders

With the demand for automation greater than ever, the need to replace limit and zone sensors on pneumatic cylinders with continuous feedback has become obvious. Speeding up and improving your process is what you need in order to stay competitive. Knowing your exact position at any given moment is essential to that end.

Replace your existing limit sensors with the GEMCO **955C BRIK GEN III** for continuous position feedback with your choice of Analog, Digital, or Quadrature outputs. The **955C BRIK GEN III** senses the magnet located in your existing pneumatic cylinder and uses it to relay absolute positioning information to the machine's controller. The **955C BRIK GEN III** can be retro-fitted to cylinders in the field using standard mounting brackets or your own customized solution. The **955C** solution has no moving parts to wear out. Magnetostrictive technology is used to "see" through the aluminum extrusion and detect the position of the magnet mounted inside the cylinder.

Three versions of the **955C BRIK GEN III** are available. The **955CA** offers analog output in either voltage or current with your choice of 0 to 10 VDC, 10 to 0 VDC, 4 to 20mA, or 20 to 4mA. The unit can easily be reconfigured in the field from a 0-10 VDC to a 10-0 VDC or 4-20 mA to a 20-4 mA output.

The **955CD** is designed for digital output with choice of Control Pulse, Start/Stop Pulse, or Variable Pulse output.

The Quadrature output from the **955CDQ** allows wiring directly to any incremental encoder input card, without the need for a special converter module or a PLC interface card. The **955CDQ** can be ordered with 1-9999 cycles per inch of output resolution in lengths of 5 to 180 inches. The transducer features an input to re-zero the probe "on-the-fly". Another unique feature is the "burst" mode. An input on the transducer triggers a data transfer of all the incremental position data relative to the set zero position. This can be used to achieve absolute position updates when power is restored to the system, eliminating the time-consuming need to "re-home" the machine.

The **955C BRIK GEN III** has truly unique features. The first one being the LDT's auto-tuning capability: the ability to sense a magnet within the pneumatic cylinder and adjust its signal strength accordingly.

Another feature is that the analog output is programmable over the entire active stroke length. The active stroke area of the LDT lies between the Null Zone and the Dead Band.

There is also a diagnostic LED located at the connector to minimize setup time and troubleshooting. The LED is green in normal operation. Red will indicate no magnet present or that the magnet has moved out of sensing range. Yellow is an indication the magnet is out of the programmed active range or if no interrogation signal is detected.

The enclosure comes standard as IP67; however, upgrading to IP68 is available as an option so the LDT can be used in wet environments.

Note: *The Pneumatic cylinder must have a magnet in order to work. Each cylinder manufacturer uses different types of magnets. In most cases the cylinder supplier installs the magnet so that the South Pole is facing out. To date, we have successfully worked with most brands of pneumatic cylinders. Consult AMETEK APT for a list of compatible cylinder manufacturers. Call 800.635.0289 to speak with a Sales Engineer.*

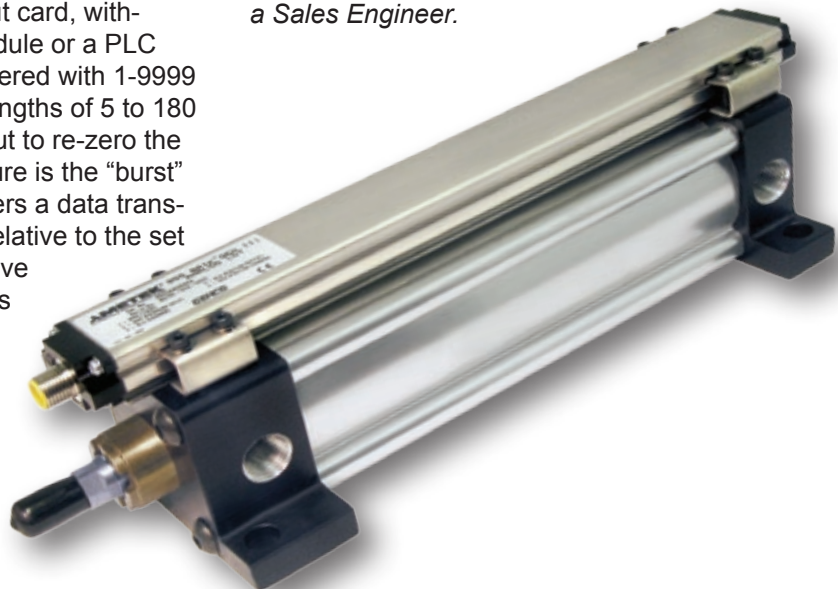

Mounting Options for the 955C LDT Specifications

SPECIFICATIONS	
Input Voltage	13.5 to 30 VDC
Current Draw	2.5 Watts Maximum, 120 mA@15 VDC Typical
Output	Analog: 0 to 10VDC, 10 to 0 VDC, 4 to 20 mA, 20 to 4mA. Digital: Control Pulse, Variable Pulse, Start/Stop Quadrature: A+, A-, B+, B-, Z+, Z- Line Drivers: 5V or Input Power
Resolution	Internal: 0.001" Analog Output: 16 Bit (1 part in 65,535) Digital Output: Controller Dependent Quadrature: 0.001"
Non-Linearity	+/- 0.05% of Stroke
Repeatability	+/- 0.006% of Full Stroke
Hysteresis	+/- 0.02% of Full Scale
Update	
 Analog	
 50" or less:	1ms
 51" to 100":	2ms
 101" to 150":	3ms
 151" to 180":	4ms
 Digital	Controller Dependent
Operating Temperature	-20° to 70° C
Span Length	5" to 180"
Null Zone	3.00"
Dead Zone	2.00"
LED	Tricolor diagnostic LED for communication of LDT status.
Connector	955CA: Standard 5 Pin Micro 12mm Euro Connector 955CD: Standard 6 Pin Micro 12mm Euro Connector 955C DQ: Standard 12 Pin Micro (option E) 12mm Euro Connector or 10 Pin HRS (option H)
Approvals	CE
Enclosure	IP 67 IP 68 Optional
<i>Specifications are subject to change without notice. Specifications are based on a typical 36" LDT.</i>	

Top Mounting Foot Part No. SD0522000

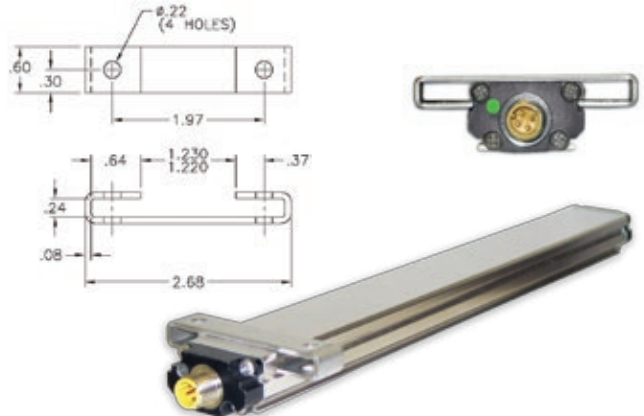

It is recommended to use one mounting bracket on each end and every 3 feet between.

Side Mounting Foot Part No. SD0559200

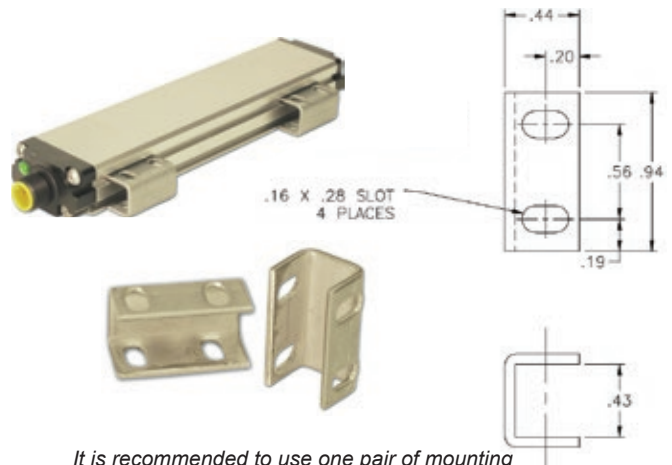

It is recommended to use one pair of mounting brackets on each end and every 3 feet between.

End Mounting Foot Part No. SD0530600

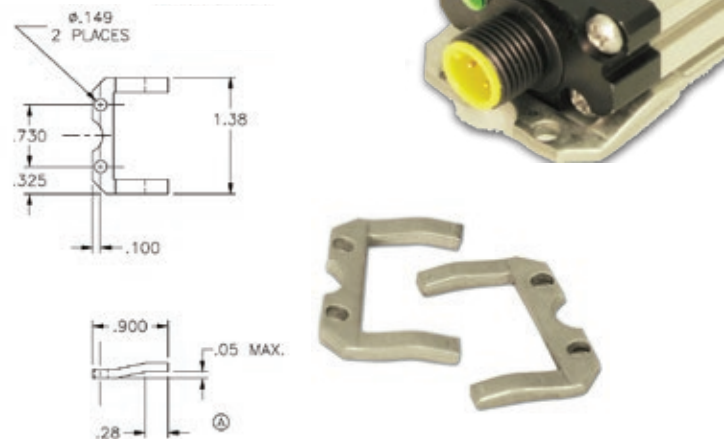

955CA Analog BRIK Gen III

Part Numbering

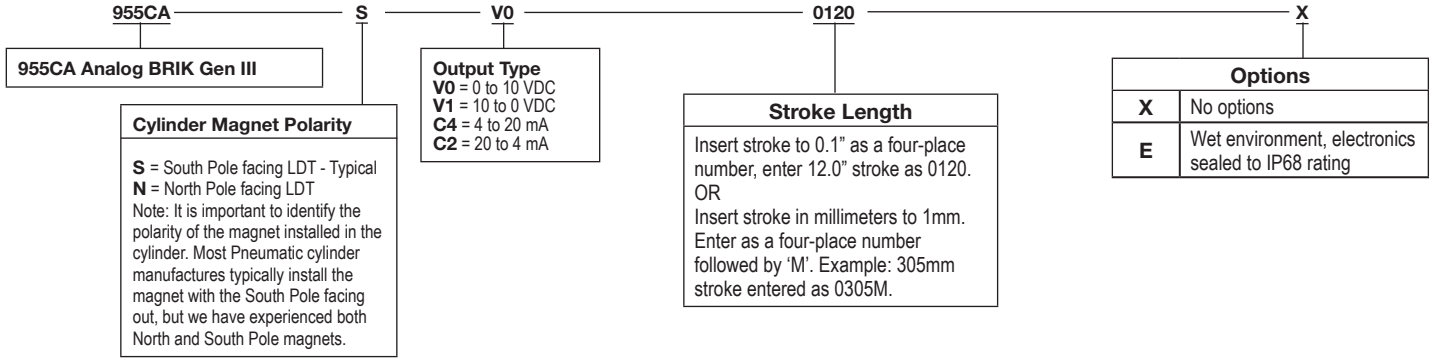

Dimension Drawing

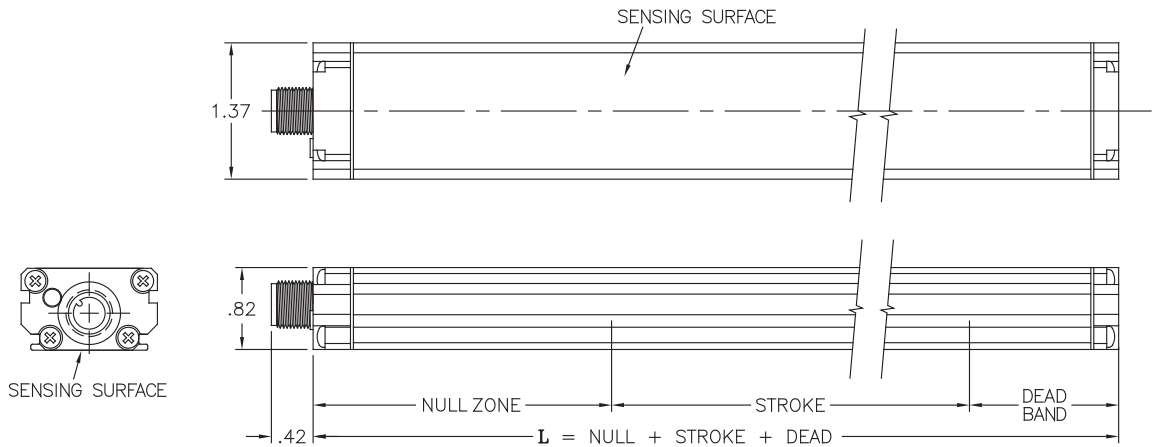

Accessories for 955CA

Item	Part Number
Top Mounting Foot (2 min. required)	SD0522000
End Mounting Feet - Set includes 2 pieces	SD0530600
Side Mounting Feet - Set includes 4 pieces	SD0559200
6 Ft. Cable, Straight Connector	949019L6
12 Ft. Cable, Straight Connector	949019L12
6 Ft. Cable, Right Angle Connector	949020L6
12 Ft. Cable, Right Angle Connector	949020L12

Wiring Diagram

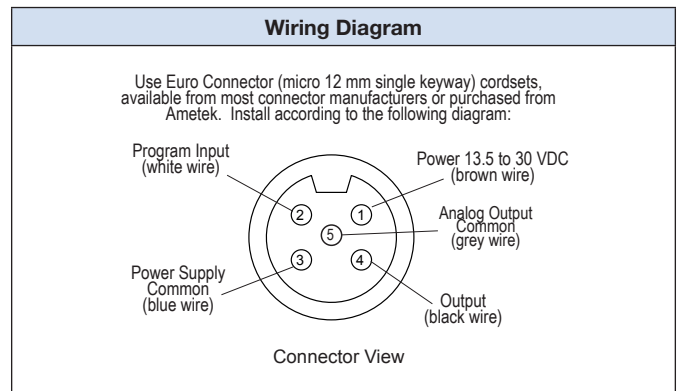

955CD BRIK Gen III Part Numbering

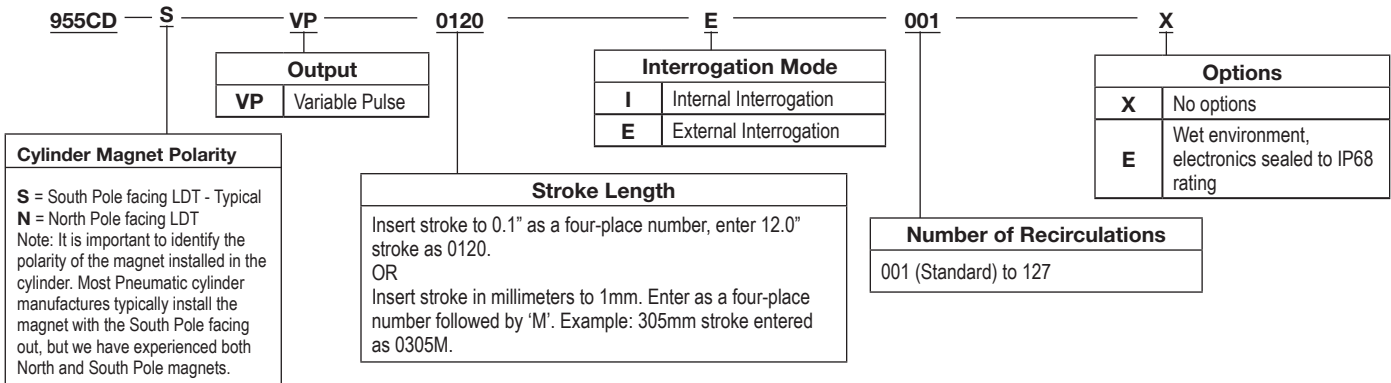
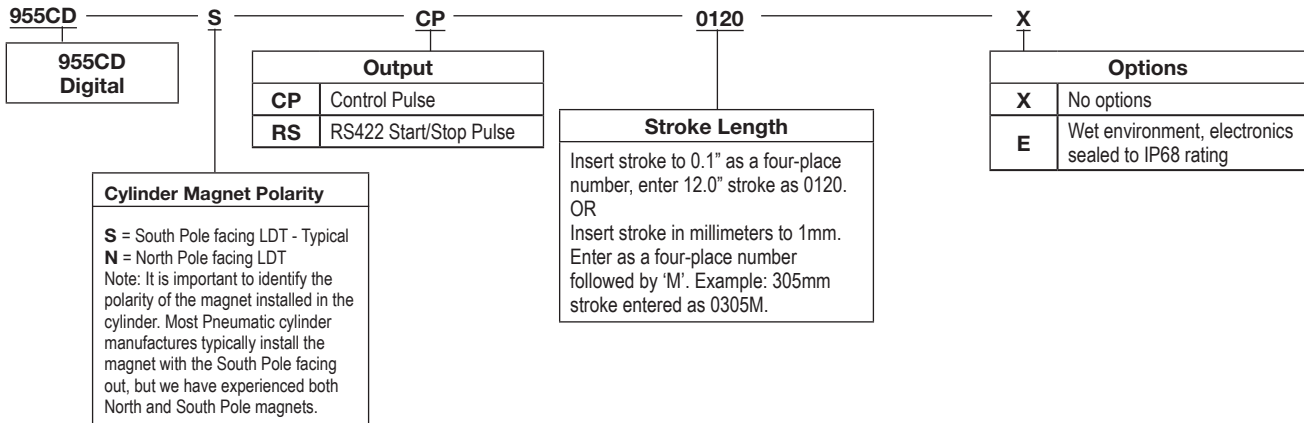

Accessories for 955CD	
Item	Part Number
Top Mounting Foot (2 min. required)	SD0522000
End Mounting Feet- Set includes 2 pieces	SD0530600
Side Mounting Feet - Set includes 4 pieces	SD0559200
6 Ft., 6 Pin Cable	949021L6
12 Ft., 6 Pin Cable	949021L12
6 Ft., 6 Pin Cable; Right Angle Connector	949022L6
12 Ft., 6 Pin Cable; Right Angle Connector	949022L12
For non-standard lengths, consult factory.	

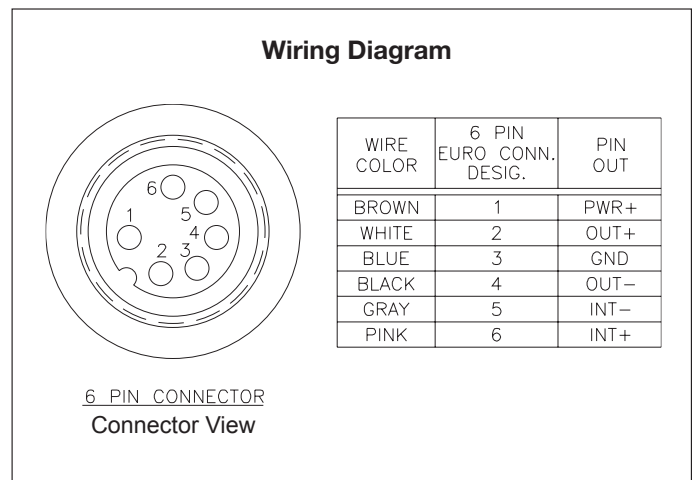

955CDQ BRIK Gen III Part Numbering

955CDQ — **S** — **0120** — **E** — **1000** — **E** — **F7** — **X1** — **N** — **D** — **X**

955CDQ Quadrature

Cylinder Magnet Polarity

S = South Pole facing LDT - Typical
N = North Pole facing LDT
Note: It is important to identify the polarity of the magnet installed in the cylinder. Most Pneumatic cylinder manufactures typically install the magnet with the South Pole facing out, but we have experienced both North and South Pole magnets.

Stroke Length

Insert stroke to 0.1" as a four-place number, enter 12.0" stroke as 0120.
OR
Insert stroke in millimeters to 1mm.
Enter as a four-place number followed by 'M'. Example: 305mm stroke entered as 0305M.

Quadrature Cycle Output Frequency Range

A1	1 kHz
A2	2 kHz
A3	5 kHz
F1	10 kHz
F2	25 kHz
F3	50 kHz
F4	75 kHz
F5	100 kHz
F6	150 kHz
F7	250 kHz
F8	500 kHz
F9	1 MHz

Options

X	No options
E	Wet environment, electronics sealed to IP68 rating, connector option E only

Output Drivers

D	Differential RS422 line driver, TTL compatible
L	Differential line driver 10 to 30 VDC, V out = V in (LDT Power) -1 Volt

Output Mode

X1	X1 quadrature, consult factory for other output modes
-----------	---

Connector Option

H	HRS environmental connector
E	Euro 12 Pin, 12mm connector, consult factory for others

Zero Offset Storage

V	Volatile (non retentive)
N	Nonvolatile (retentive, 100,000 storage cycles maximum)

Output Resolution

Cycles per inch, maximum internal resolution is 0.001 inches 1000 standard (available range is 0001 through 9999)

Input

E	Sinking (typically used with sourcing output type)
C	Sourcing (typically used with sinking output type)
T	TTL Level

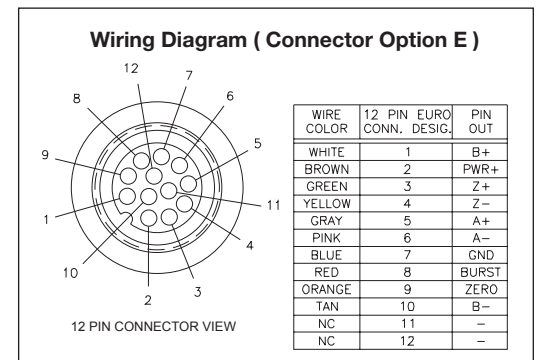
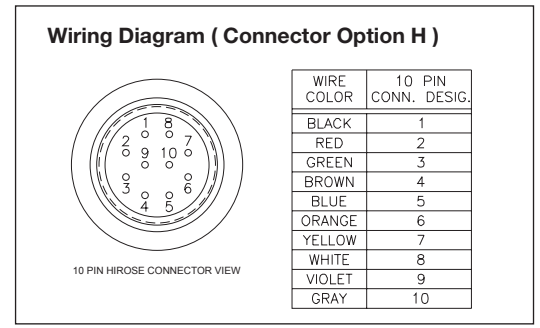

Accessories for 955CDQ	
Item	Part Number
Top Mounting Foot (2 min. required)	SD0522000
End Mounting Feet - Set includes 2 pieces	SD0530600
Side Mounting Feet - Set includes 4 pieces	SD0559200
6 Ft. Cable (Option H Connector)	SD0527700L6 OBSOLETE Consult Factory
12 Ft. Cable (Option H Connector)	SD0527700L12 OBSOLETE Consult Factory
25 Ft. Cable (Option H Connector)	SD0527700L25 OBSOLETE Consult Factory
6 Ft., 12 Pin (Option E Connector)	949023L6
12 Ft., 12 Pin (Option E Connector)	949023L12

For non-standard lengths, consult factory.

955

Gemco 956 BLOK Housing Option

The 956 BLOK is an optional housing for the 955 BRIK Series of Linear Displacement Transducers. This housing adds a chamber, magnet and piston.

The streamlined anodized aluminum extrusion houses the sensing element and electronics. The piston assembly moves over the sensing element that determines the position and converts it to a readable output.

The 956 BLOK is a self-contained unit and does not have a can or head assembly. All of the electronics are incorporated in the transducer which is less than 1.5 inches square. Units can be ordered in span lengths up to 36 inches long in 0.1 inch increments. The piston is designed to move effortlessly along the transducer. A variety of hardware is available for attaching the LDT to the moving portion of the process. All units are provided with a standard quick disconnect connector.

The transducer can be mounted vertically or horizontally using mounting feet or optional rod ends. The mounting feet slide on the extrusion and clamp down when tightened. This package style provides a compact and easy method of mounting for machine builders.

The 956 BLOK is designed for applications where economical continuous feedback is necessary. The sensor can be a cost effective replacement to limit and proximity sensors and linear potentiometers. Applications include presses, blow molding, injection molding, extrusion, roll positioning, wicket gates and many more.



Shown with optional
Metal Rod End.

Specifications

Because the 956 BLOK is an optional housing for the 955, electrical specifications are dependant on the particular 955 sensor. See the 955 BRIK pages for specifications.

Approvals	CE
Enclosure	IP67 (Optional IP68)

Specifications are subject to change without notice.

Part Numbering

To determine a 956 part number, replace the '955' in a 955 BRIK part number with '956'. Typical span lengths range from 6" to 36". Consult factory for other lengths.

955 -S-V0-0120
956 -S-V0-0120-X

An option signifier from the table below must also be added to the end of the part number.

956 Options

X	No Options - Male Piston 1/4" - 28 Threads.
E	Wet Environment. Electronics sealed to IP 68 Rating.
F	Front Metal Rod End, Female - used with option "X".
R	Rear Metal Rod End (Connector End), Female - used with option "X".
A	Tapped Female Piston Rod 1/4" -28 .
S	Stainless Steel Front Rod End used with option "A".
T	Stainless Steel Rear Rod End (Connector End) used with option "A".

Accessories

Item	Part Number
Spacer Kit Mount feet for .45" or .75" mounting Includes two mounting feet & spacers	SD0545100
Metal Rod End, Female for Option "F"	04-570256
Mounting Foot	SD0522000
Stainless Steel Rod End 1/4-28 Male for Option "A"	04-570264

956 BLOK Housing

Dimensions - Standard 956 Housing with Option X

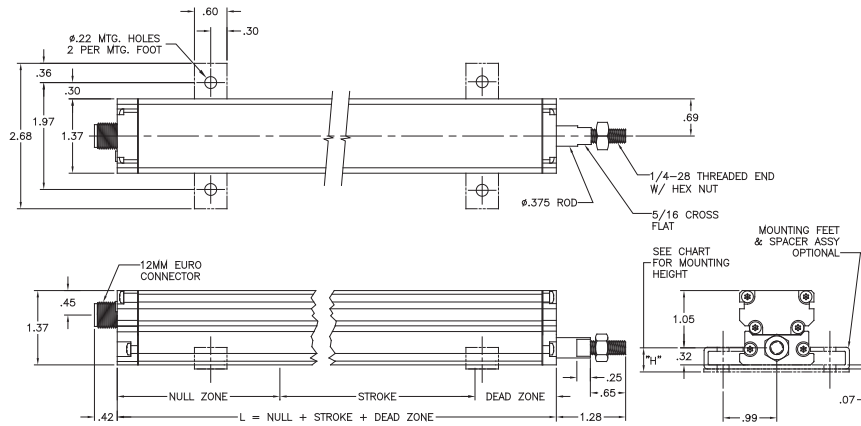

Dimensions - 956 Housing with F, R, and X Options

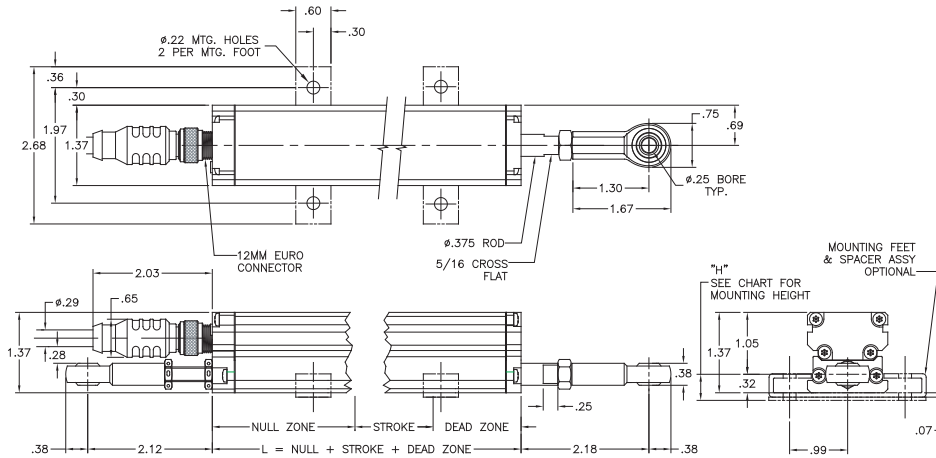

NOTE: SEE PROBE SPECIFICATION FOR NULL & DEAD ZONE DIMENSIONS.

SPACER PART NO.	MOUNTING HEIGHT "H"
S0083900	.45
S0083901	.75

Dimensions - 956 Housing with S, T, and A Options

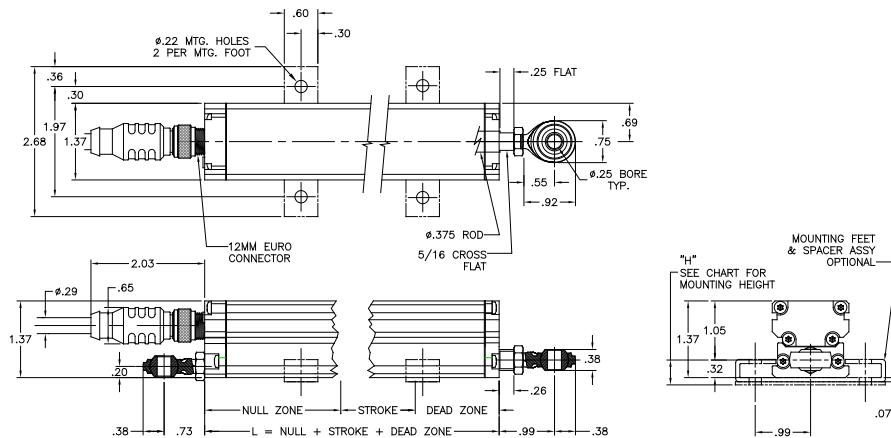

NOTE: SEE PROBE SPECIFICATION FOR NULL & DEAD ZONE DIMENSIONS.

SPACER PART NO.	MOUNTING HEIGHT "H"
S0083900	.45
S0083901	.75

7230 HT Digital Probe

Proven Magnetostrictive Sensing Performance Integrated with a Modbus or ASCII Digital Multivariable Protocol

The 7230 HT Digital Probe is a new magnetostrictive level measurement probe from Ametek APT for the up-stream oil and gas industry where multi-layer and temperature data is critical to everyday operations.

The 7230 Probe is a level measurement solution that provides both total and interface levels as well as temperature readings from up to 5 discreet positions. All the data is collected by installing a single sensor through a single process connection, eliminating the need for multiple sensors and insertion points. The 7230 Series is approved as Explosion Proof (without intrinsic safety barriers) for Class I, Div. 1 and Zone 1 hazardous locations.

The 7230 is available with a choice of either Modbus RTU or ASCII communication protocols. An optional analog interface module is also available for use with the Modbus RTU output. This option allows for multivariable 4-20mA outputs.

All of this performance is enhanced by Ametek APT's patented magnetostrictive design. Magnetostrictive technology requires no calibration yet provides the highest accuracy of any of the most popular level technologies that are currently offered in today's market. The 7230 Probe is no exception, as it exceeds the high accuracy of the proven 7330 Analog STIK with an impressive accuracy of 0.01% of measured span.

Product Features

- Multivariable readings
- Modbus or ASCII Protocol
- High accuracy
- Reliable level measurement
- Material's electrical characteristics and densities do not affect readings
- Easy to install, no technician needed
- Mixed hydrocarbons will not cause level measurement errors
- A variety of floats are available



Specifications		
Enclosure Type	Type 4/4X IP66	Approvals FM (US and Canada) XP Class I, Div I, Group A, B, C, D, T4 DIP Class II, III, Group E, F, G, T4 
Output Signal/Protocol*	Level, Interface, Temperature RS-485, Modbus RTU	
Data	Signed, Long, Binary	
Range Temp.	-40°F to 257°F Process -40°F to 158°F Ambient	
Pressure Rating, Wetted Parts	316SS Probe: 1000 psi max. Float Dependent: Consult Factory	
Wetted Parts	316LSS	
Probe Length	Up to 24 foot, 21" to 288"	
Accuracy	0.01% of Span	
Power Supply	10 to 30 VDC 40mA @ 30 VDC max. 26mA @ 24 VDC Typical	
Null Zone	9.25"	
Dead Band	2.75"	
Specifications are subject to change without notice. Patented. *7235 also available with TTL, proprietary output signal.		

7230 HT Digital Probe Part Numbering

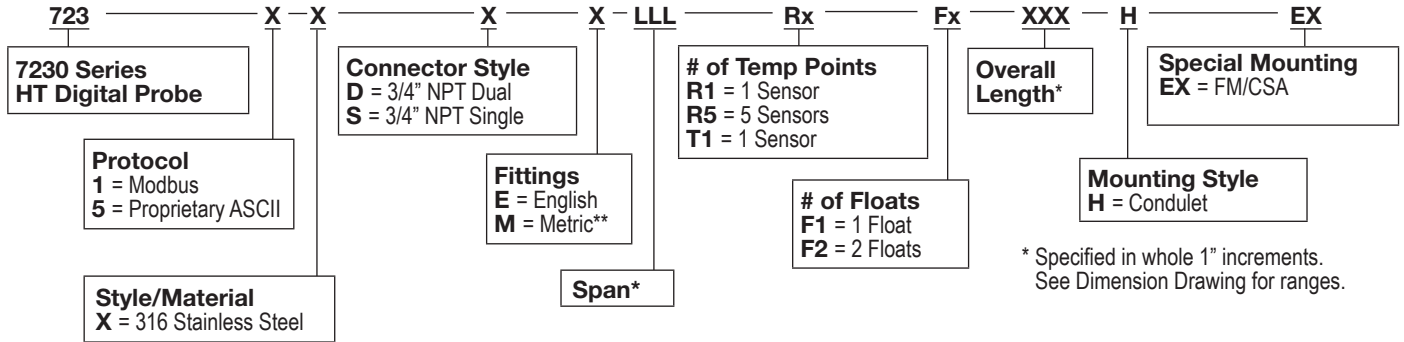

Dimension Drawing

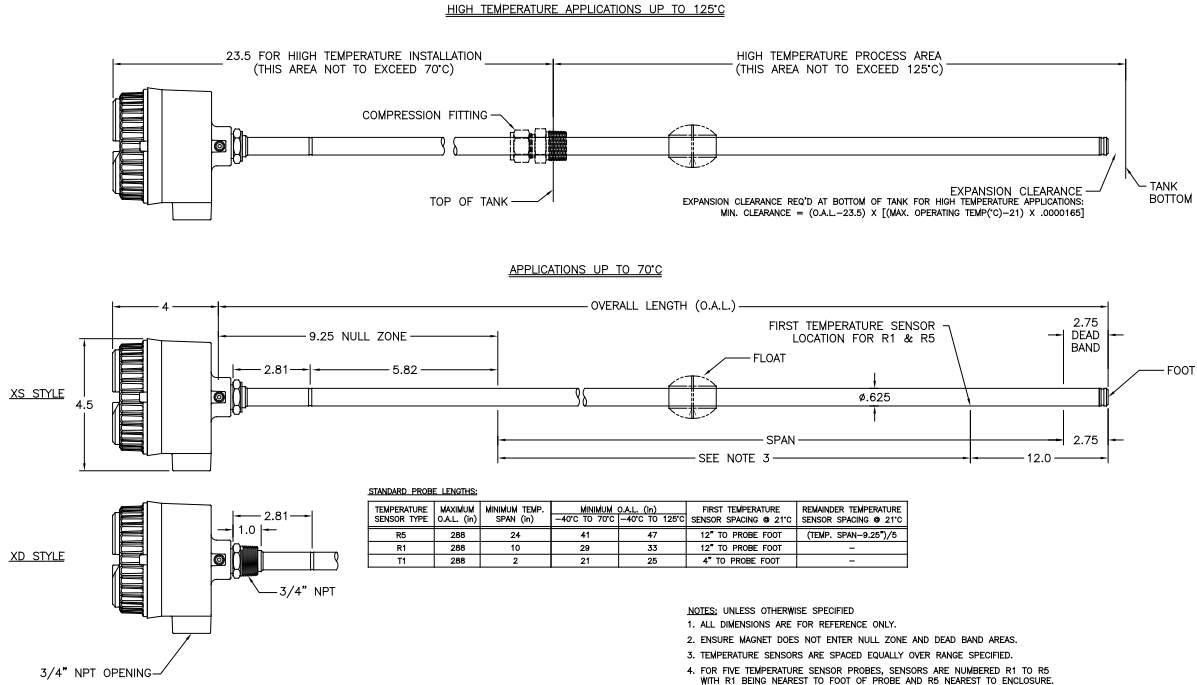

Accessories	
Item	P/N
Float Kit: Level Float, 316SS, 2.05" dia., 0.54sg Float, E-clip & spacer	SD0557200
Float Kit: Interface Float, 316SS, 2.05" dia., 0.96sg Float, E-clip & spacer	SD0556800
Float Kit: Level Float, Nitrophyl 2.0" d x 3.0" h 0.40sg, E-clip & spacer	SD0548600
Float Kit: Interface Float (w/Nitro. level float), 316SS, 2.05" dia., 0.96sg, E-clip & spacer	SD0557300
Adjustable Tube Coupling: 316SS, 5/8" x 3/4" NPT	04283800
Reducing Bushing: 316SS, 2" x 3/4" NPT	04587241
Analog Interface Board: Modbus RTU to analog (4-20mA) converter	04534047

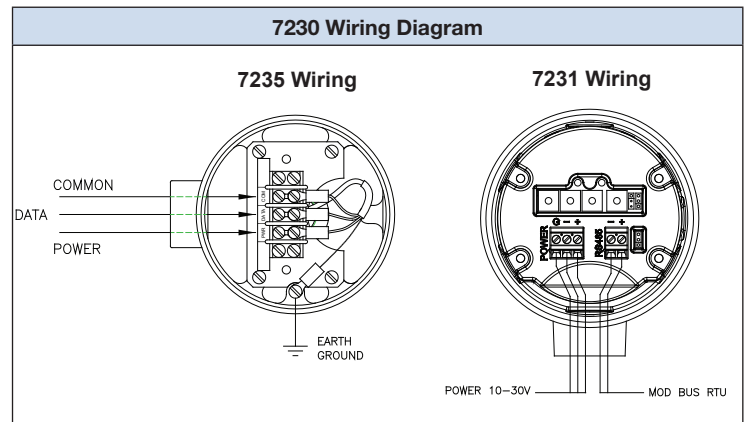

7330 Pro-Stik II

Intrinsically Safe Programmable Linear Position Sensor

The 7330 Pro-Stik II sensor combines the reliability and resolution of magnetostrictive continuous absolute positioning sensing with the Stik sensor package to create a unique level measuring instrument.

The magnetostrictive technology is the same as used in Gemco LDT sensors. Ametek liquid level sensors have been proven in demanding applications such as underground leak detection and inventory management. The 7330 is available with a rigid 316 stainless steel or flexible PVDF materials.

All of the electronics are SMT components integrated into the 5/8" diameter sensing tube. This breakthrough in package design eliminates the electronics enclosure at the top of the sensor, which reduces the cost and offers greater options for insertion and mounting in tanks and vessels.

Continuous position data is provided with resolution of .014". The two wire loop powered 4 to 20mA intrinsically safe output is field programmable for zero and span via a separate programming pin. The position data is absolute and can be referenced from the top or bottom of the probe.

The rugged, all welded 316 stainless steel construction is ideal for industrial, food processing, pharmaceutical, sanitary environments and even hazardous areas requiring intrinsically safe protection.

The sanitary and food grade versions of the Stik are totally welded, ground and polished, and can be easily installed with the Tri-clamp fitting. The 7330S probe design eliminates unacceptable cracks and crevices and is available in a 3-A CIP version or food grade finish with a removable float. A variety of floats, magnets, and mounting options are available to fit virtually any application.



Specifications	
Operating Voltage	13.5 to 30 VDC
Loop Impedance (R)	0 to 1000 @ 24 volts
Output	4 to 20mA
Operating Temperature	-20° to 70° C
Pressure Rating	1000 psi Max.
Resolution	0.025% full scale or 0.02" (whichever is greater)
Repeatability	0.025% full scale or +/-0.020" (whichever is greater)
Accuracy	0.1% or .050" (whichever is greater)
Enclosure: Material Rating	Probe: 316 SS or PVDF IP68
Probe Length Stainless Steel	20" to 288"
Null Zone	8"
Dead Band	2"
Intrinsically Safe Barrier	Voc less than or equal to 31 VDC Isc less than or equal to 165mA
Approvals	Hazardous Areas Approvals FM, CSA -20° ≤ Tamb ≤ 70° C Class I, II, III, Div. 1 Groups C, D, E, F, G, T4 Class I, Div. 2 Groups A, B, C, D, T4 Class I, Zone 0, AEx ia IIB T4 ATEX Ex ia IIB T4 NEMKO 04 ATEX 1357X CE 0344 EX II 1G



Specifications may change without notice. Patented.

7330 Pro-Stik II Part Numbering

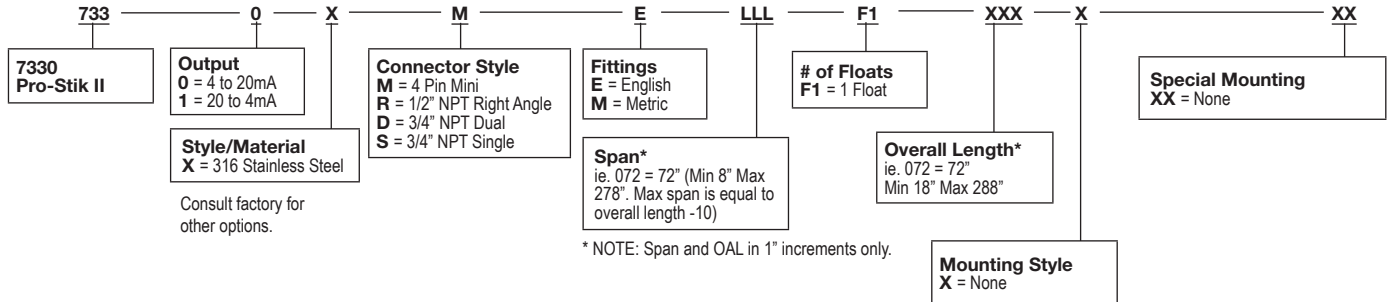

Dimension Drawing

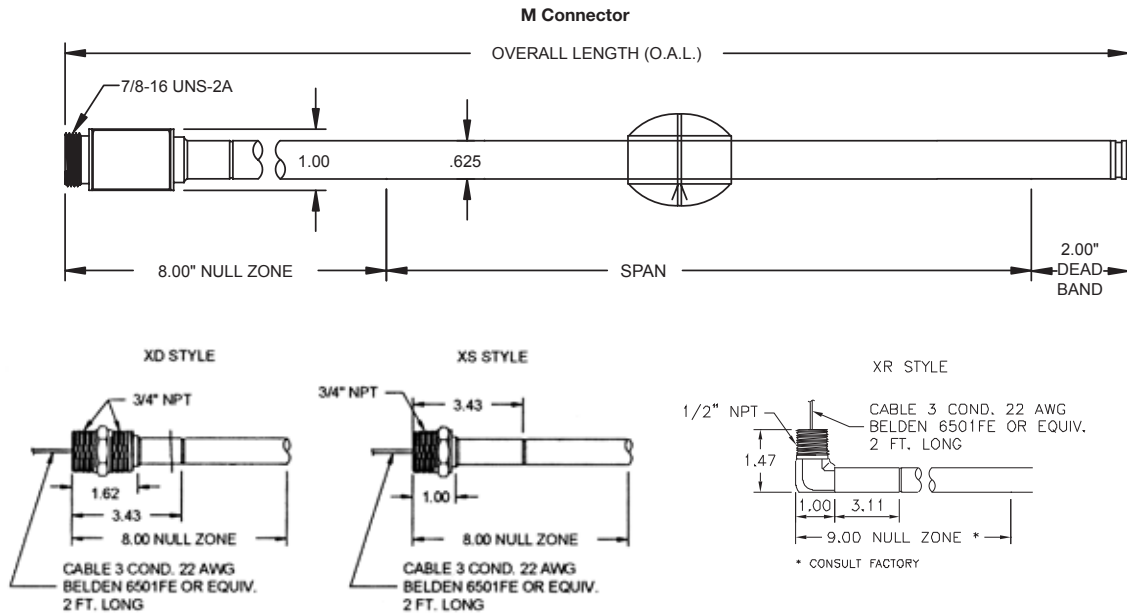

Accessories	
Item	Part Number
Float Kit, 316 SS, 2.05" Diameter w/ E Clip and Spacer 0.54s.g.	SD0515000
Float Kit, Nitrophyl, 2.02" Diameter w/ E Clip and Spacer 0.40s.g.	SD0536500
Cable Assembly, 4 pin, 6 feet long (M style only)	01533141
Adjustable Tube Coupling 5/8" x 3/4" NPT	04283800
Junction Box, side mount, N4X with zero & span push buttons	SD0536101
Safety Barrier Single Channel	04517238
Safety Barrier Dual Channel	04517248
Meter, 4 1/2 digit display, panel mount, 2 output relays	04541069
Bushing, 3/4" x 2" NPT 316SS	04587241

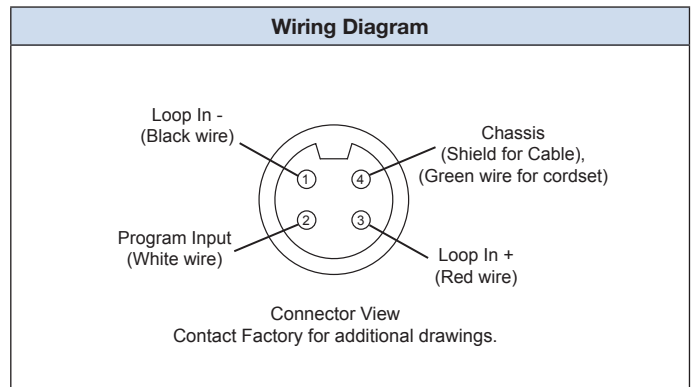

7330EX/ED Pro-Stik II

Explosion/Flame Proof Design Integrated with Magnetostrictive Technology

The 7330 EX/ED Series Pro-Stik II takes field proven magnetostrictive sensing technology and incorporates features such as explosion/flame proof design and field programmable span. This is packaged in our patented Stik design, making the Pro-Stik II ideal for level monitoring in a variety of liquids and tanks. Sensors are available in rigid 316 stainless steel up to 24 feet.

The 7330 EX/ED Series Pro-Stik II is a loop powered explosion/flame proof sensor with a scalable 4 to 20mA span that provides 0.1% accuracy, full scale. Calibration is not required, although the upper and lower limits of the Span can be programmed in the field.

The sensor's electronics are SMT components in a 5/8" diameter sensing tube. This packaging breakthrough improves the environmental seal to the electronics.

The 316 stainless steel sensor is available with 3/4" NPT mounting threads or an optional tube coupling. The housing has terminal connections as well as Zero/Span push buttons. The stainless steel provides a totally welded construction and may be offered with cathodic protection.

The probe provides a security feature by utilizing a timing sequence that is used to unlock the probe for programming. This ensures that the span cannot be accidentally programmed by someone in the field.

The unique diagnostic output provides continuous information about the float's position and passcode protection for programming.

If The float is...	Output
Below set span, but within active region	3.9mA
Above set span, but within active region	20.1mA
Either above or below active range or signal is lost	3.8mA

A variety of floats and mounting accessories are available to fit virtually any application.



Specifications	
Operating Voltage	13.5 to 30 VDC
Output	
Operating Output	4 to 20mA
Diagnostic Output	3.9mA and 20.1mA, float outside of span 3.8mA, no signal received (Note: Diagnostic Tolerance +/- 0.02mA)
Operating Temperature	-40° to 70° C, (-40° to 158° F)
Pressure Rating	316SS Probe: 1000 psi max. Float Dependent. Consult Factory.
Resolution	0.025% of span or 0.014" (Whichever is Greater)
Repeatability	0.014" + 0.05% of span typical, 0.014" + 0.4% of span maximum
Accuracy	0.1% of span or 0.050" (Whichever is Greater)
Null Zone	8"
Dead Band	2"
Enclosure Material Rating	Probe: 316 SS IP68
Probe Length Stainless Steel D, S	18" to 288" * Consult Factory
	Approvals
	 FM (US & Canada) XP Class I, Div I, Group A, B, C, D, T4 DIP Class II, III, Group E, F, G, T4
Specifications are subject to change without notice. Patented.	

7330EX/ED Pro-Stik II Part Numbering

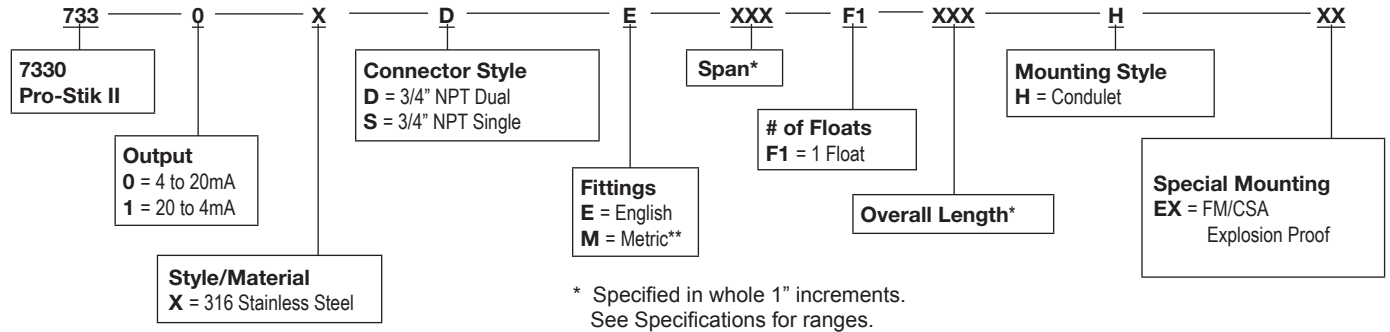

Dimension Drawing

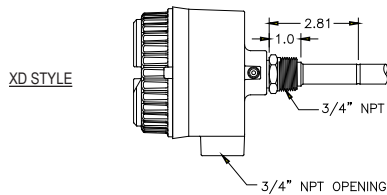
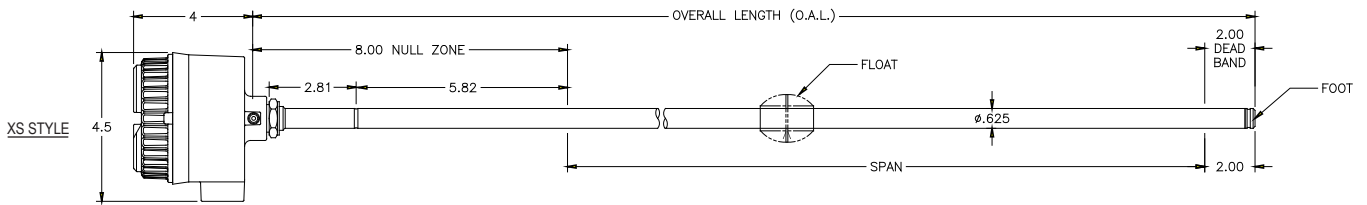

MAXIMUM STANDARD OVERALL LENGTH = 288"
MINIMUM STANDARD OVERALL LENGTH = 18"

NOTES: UNLESS OTHERWISE SPECIFIED
1. ALL DIMENSIONS ARE FOR REFERENCE ONLY.
2. ENSURE MAGNET DOES NOT ENTER NULL ZONE AND DEAD BAND AREAS.

Accessories	
Item	Part Number
Float Kit, 316 SS, 2.05" Diameter w/ E Clip and Spacer 0.54s.g.	SD0515000
Float Kit, Nitrophyl, 2.02" Diameter w/ E Clip and Spacer 0.40s.g.	SD0536500
Cable Assembly, 4 pin, 6 feet long (M style only)	01533141
Adjustable Tube Coupling 5/8" x 3/4" NPT	04283800
Meter, 4 1/2 digit display, panel mount, 2 output relays	04541069
Bushing, 3/4" x 2" NPT 316SS	04587241

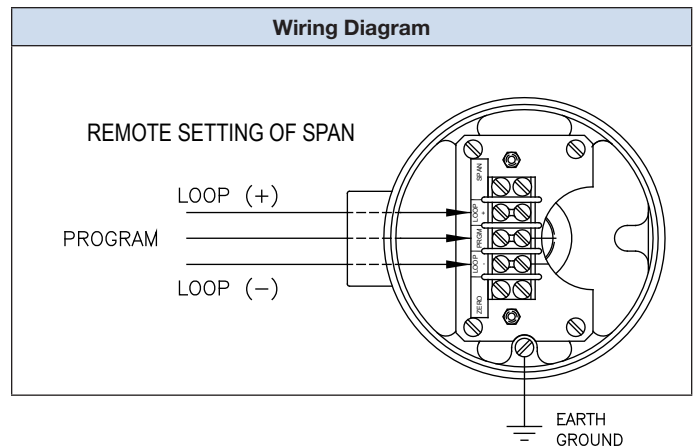

7330



Rod Style LDT Accessories

Description	Part Number	950IS	952	952QD	953	7230	7330	950MD
Standard 4 Hole Rod Magnet	SD0400800	✓	✓	✓	✓			
Stainless Steel 4 Hole Magnet	SD0480900	✓	✓	✓	✓			
Non-Ferrous Spacer for 4 Hole Magnet	M0822400	✓	✓	✓	✓			
Aluminum Split Mag. Assembly	SD0403900	✓	✓	✓	✓			
Non Ferrous Spacer for Split Magnet	M0750500	✓	✓	✓	✓			
Large Split Magnet Assy for use w/ Rod Supports (P/N SD0411200)	SD0411200	✓	✓	✓	✓	✓	✓	
Large Split Mag S.S., Assy for use with Rod Supports (P/N SD0411200)	SD0411201	✓	✓	✓	✓	✓	✓	
Cylinder and 950MD Magnet	SD0410300	✓	✓	✓	✓			✓
Teflon Coated Cylinder Magnet	SD0410301	✓	✓	✓	✓			✓
Float Kit Level Float, 316SS, 2.05" dia., 0.54sg Float, E-clip & spacer	SD0557200					✓		
Float Kit Interface Float, 316SS, 2.05" dia., 0.96sg Float, E-clip & spacer	SD0556800					✓		
Float Kit Level Float, Nitrophenyl, 2.0" d x 3.0" h 0.40sg, E-clip & spacer	SD0548600					✓		
Float Kit Interface Float (w/Nitro. level float), 316SS, 2.05" dia., 0.96sg, E-clip & spacer	SD0557300					✓		
Adjustable Tube Coupling 316SS, 5/8" x 3/4" NPT	04283800					✓	✓	
Reducing Bushing 316SS, 2" x 3/4" NPT	04587241					✓	✓	
Analog Interface Board Modbus RTU to analog (4-20mA) converter	04534047					✓		
Float Kit Level Float, 316SS, 2.05" dia., 0.54sg Float, E-clip & spacer	SD0515000						✓	
Float Kit Level Float, Nitrophenyl, 2.0" dia., 0.40sg, Float & E-clip	SD0548600						✓	
Stainless Steel Float Miniature, .62 SG	04-535090		✓					
Stainless Steel Float Egg Shape, .66 SG	04-535091		✓		✓			
Float and Stop Kit Contains Float and Clamp	SD0565000				✓			

Misc.

Rod Magnets

Standard 4 Hole Magnet

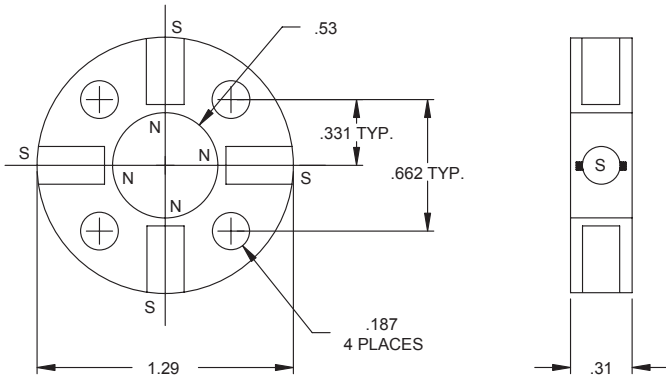

Standard P/N: SD0400800
Stainless Steel P/N: SD0480900

Non-Ferrous Spacer for 4 Hole Magnet

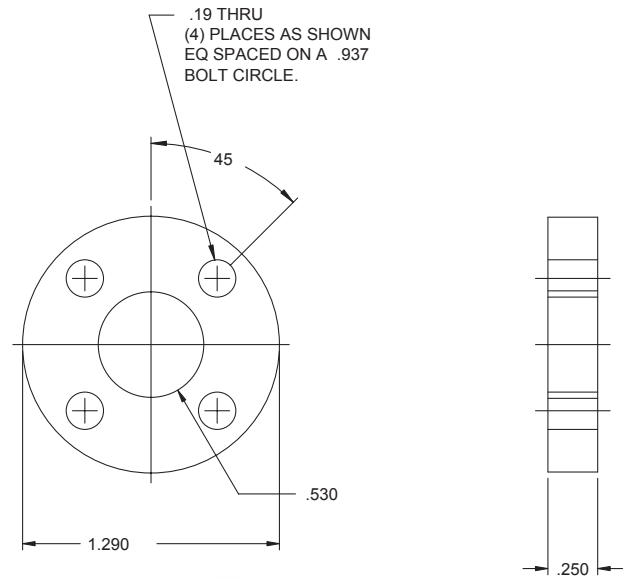

MATERIAL: ALUMINUM
P/N: M0822400

Aluminum Split Magnet

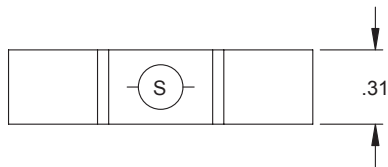

MAT'L: ALUMINUM
P/N: SD0403900

Non-Ferrous Spacer for Split Magnet

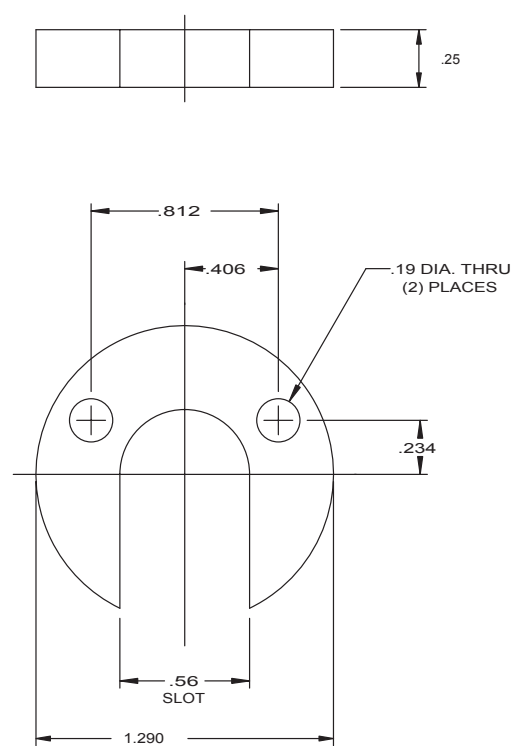

MAT'L: ALUMINUM
P/N: M0750500

Rod Magnets

Large Split Magnet

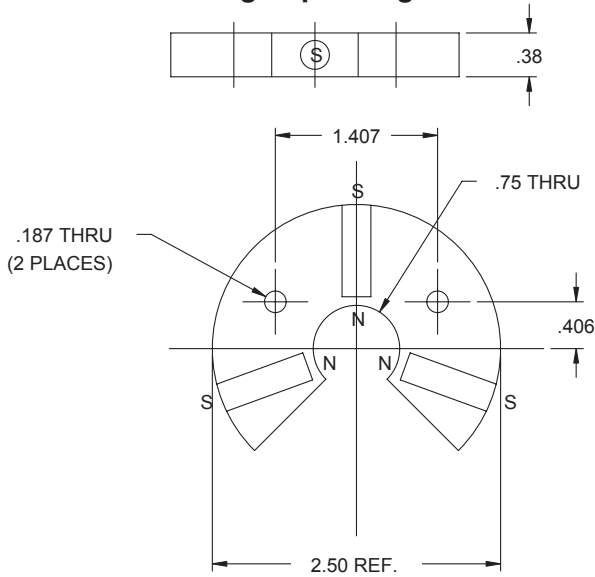

NOTE: USE THIS MAGNET WITH ROD
SUPPORT BRACKET SD0411100

Standard P/N: SD0411200
Stainless Steel P/N: SD0411201

Cylinder Magnet

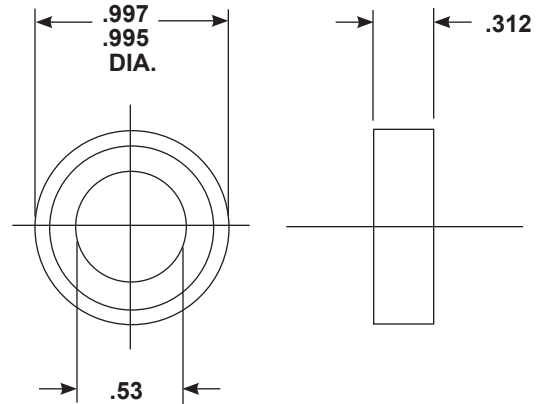

Standard P/N: SD0410300
Teflon Coated P/N: SD0410301

Stainless Steel Float

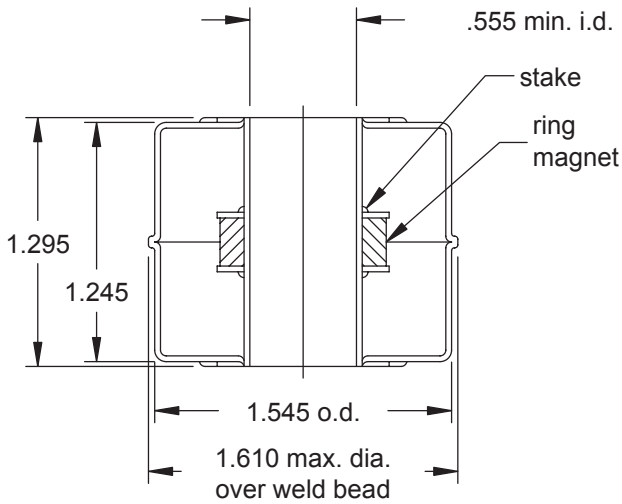

* For use with 952
P/N: 04535090

Stainless Steel Float

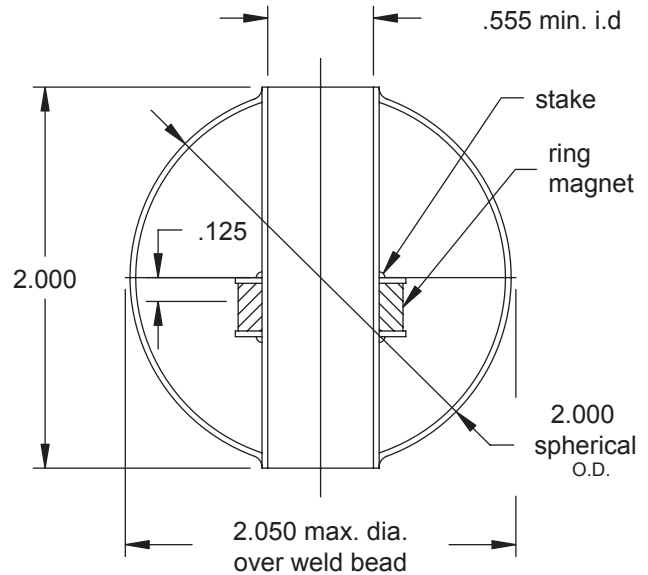

* For use with 952 & 953.
P/N: 04535091

955-956 Accessories

955 Slide Magnet
P/N: SD0521800

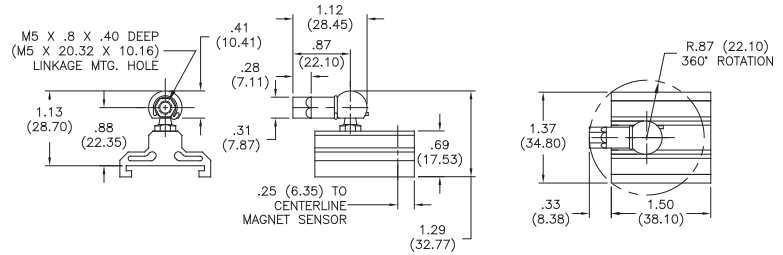

955 Slide Magnet Side Adapter
P/N: SD0521801

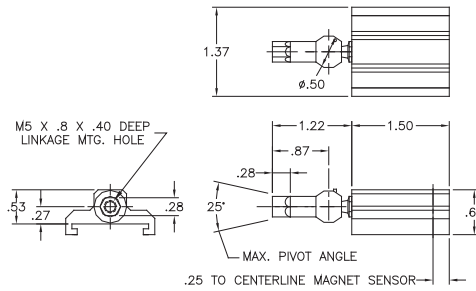

955 Floating Magnet
P/N: SD0522100

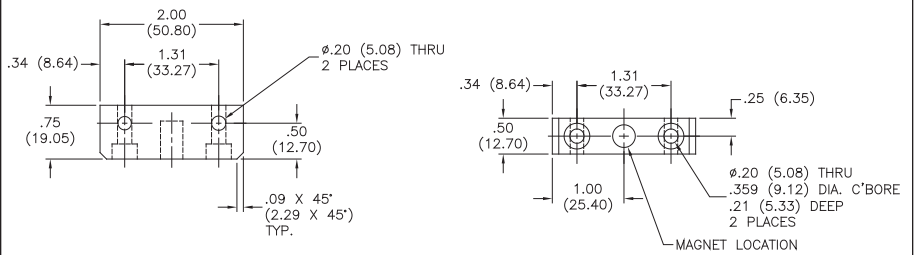

955 Wide Floating Magnet
P/N: SD0551500

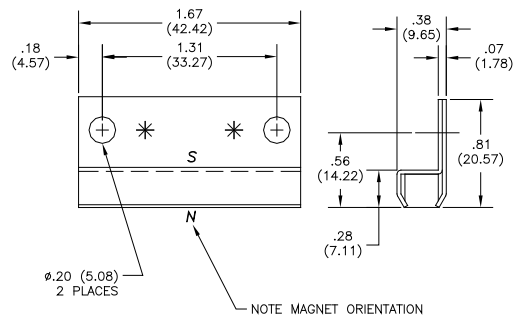

955 Mounting Foot
P/N: SD0522000

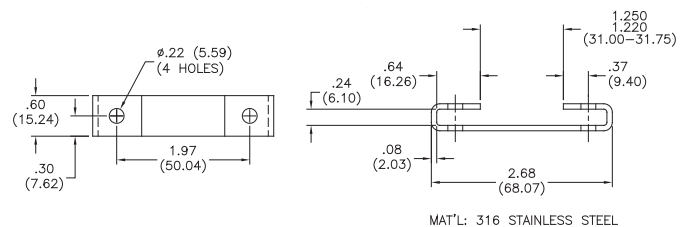

955-956 Accessories

955 Control Arm
P/N: 955ARMXX (X = Inches)

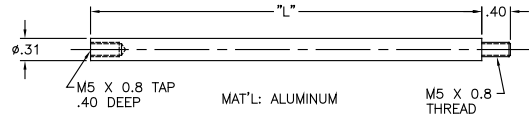

955 Plastic Rod Ends for Control Arms
P/N: 04-570252

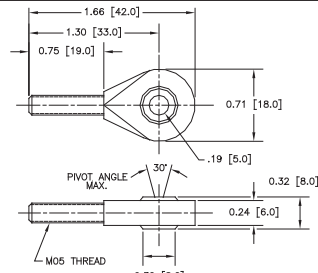

956 Optional Optional Metal Rod End Option "F" & "R" for 956 BLOKS
P/N: 04-570256

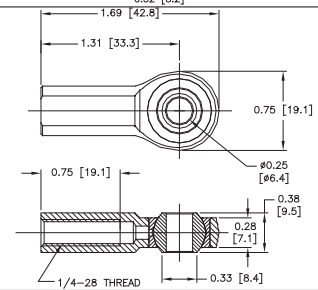

956 Optional Stainless Steel Male Metal Rod End Option "S" & "T" for 956 BLOKS
P/N: 04-570264

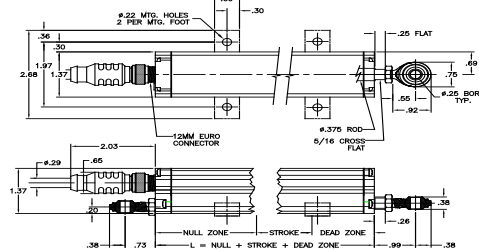
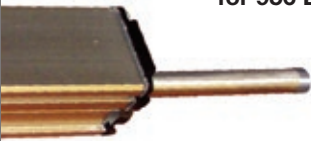

In-Line Programming Unit
P/N: 9551409



Battery Operated Test/Programming Unit

Use with 955e, 955S, 955A, 956S, 956A, 952A with connector option 'S', 953A with connector option 'S'

P/N: SD0528811 for Current Unit
P/N: SD0528810 for Voltage Unit



Cable Assemblies

Description and Part Number	950IS	950MD	951	952	952QD	953D	953A	953SSI	955LC	955e	955S	955DQ	955D	955A	956	7230	7330
7330 Cable P/N 01533141																	✓
2 Pin Mini 16mm Euro Molded Cable P/N 04521210	✓																
4 Pin Micro 12mm Euro Straight Cable P/N 949001LXX									✓		✓						
4 Pin Micro 12mm Euro Right Angle Cable P/N 949002LXX									✓		✓						
5 Pin Micro 12mm Euro Straight Cable (shielded) P/N 949011LXX							✓ ¹										
5 Pin Micro 12mm Euro Right Angle Cable (shielded) P/N 949012LXX							✓ ¹										
5 Pin Micro 12mm Euro Straight Cable P/N 949019LXX				✓ ¹						✓				✓			
5 Pin Micro 12mm Euro Right Angle Cable P/N 949020LXX				✓ ¹						✓				✓			
5 Pin Micro 12mm Euro Straight SS Cable P/N 949013LXX		✓ ²															
6 Pin Micro 12mm Euro Straight SS Cable P/N 949031LXX		✓ ³															
6 Pin Micro 12mm Euro Right Angle Cable P/N 949032LXX		✓ ³															
6 Pin Micro 12mm Euro Straight Cable P/N 949021LXX													✓				
6 Pin Micro 12mm Euro Right Angle Cable P/N 949022LXX													✓				
6 Pin Micro 12mm Euro Straight Cable P/N 949029LXX						✓ ¹		✓ ¹									
6 Pin Micro 12mm Euro Right Angle Cable P/N 949030LXX						✓ ¹		✓ ¹									
7 Pin DIN - M Connector Option Straight Cable P/N SD0558500LXX								✓ ⁷									
12 Pin Micro 12mm Euro Straight Cable P/N 949023LXX												✓					
MTS-6 pin, "M" Option, (Voltage or Current Outputs) P/N SD0553200LXX							✓ ⁷										
Balluff-8 pin, "B" Option, (Voltage Outputs Only) P/N SD0553300LXX							✓ ⁸										
Balluff-8 pin, "B" Option, (Current Outputs Only) P/N SD0553400LXX							✓ ⁸										
MTS-6 pin, "M" Option, (Digital Outputs) P/N SD0554500LXX						✓ ⁷											
Balluff-8 pin, "B" Option, (Digital Outputs) P/N SD0554600LXX						✓ ⁸											
10 Pin Micro 12mm Euro Straight Cable P/N SD0527700LXX												✓ OBS					
10 Pin Straight Cable Assy P/N SD0439700LXX		✓ ⁴	✓	✓	✓	⁵	✓ ⁵	✓ ⁵									
10 Pin Right Angle Cable Assy P/N SD0439701LXX		✓ ⁴	✓	✓	✓	✓ ⁵	✓ ⁵	✓ ⁵									
10 Pin Straight High Temp Cable Assy P/N SD0465500LXX		✓ ⁴	✓	✓	✓												
951, 952, 953 Analog Cable Termination Kit P/N SD0443803L25			✓	✓ ⁵			✓ ⁵										
951, 952, 953 Digital Cable Termination Kit P/N SD0443800			✓	✓ ⁵		✓ ⁵											
953D Digital Cable Termination Kit P/N SD0443804L25						✓ ⁶											

NOTE: XX = Length in Feet.

¹ Option S Connector. ⁴ Option C2 Connector. ⁷ Option M Connector.

² Option C3 Connector. ⁵ Option E Connector. ⁸ Option B Connector.

³ Option C4 Connector. ⁶ Option S Connector.

Misc.

Cable Accessories

10 Pin Straight Cable
(951, 952, & 953 Connector Option E)

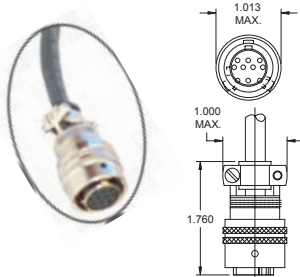

4, 5 & 6 Pin Micro 12mm Euro Straight Cable
(955, 956, 952A, 953)

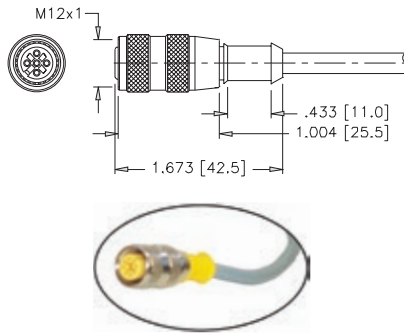

10 Pin Straight Cable
(955DQ Connector Option H)
(OBSOLETE)

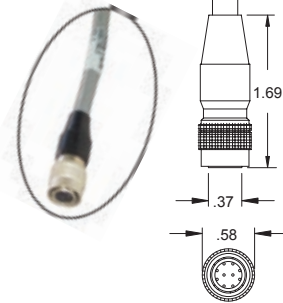

10 Pin Right Angle Cable
(951, 952, & 953 Connector Option E)

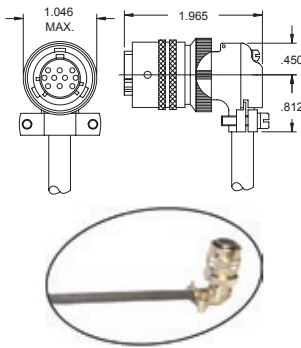

4, 5 & 6 Pin Micro 12mm Euro Right Angle
(955, 956, 952A, 953)

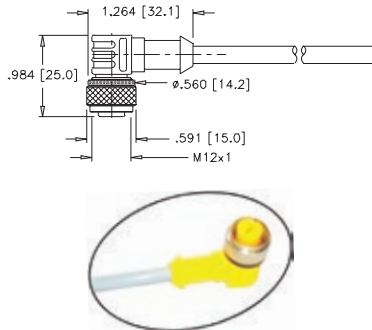

Universal Mounting Kit
P/N: SD0441300



2 Pin Mini 16mm Euro Molded Cable
(950IS)

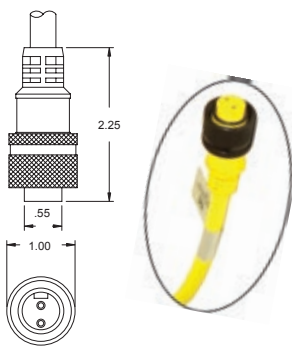

12 Pin Micro 12mm Euro Straight Cable
(955DQ Connector Option E)

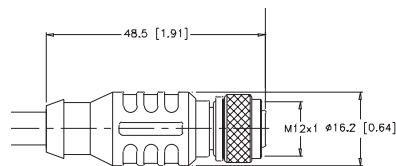

Cable Termination Kit
951, 952 Digital P/N: SD0443800L25
951, 952 Analog P/N: SD0443803L25
953 Digital P/N: SD0443804L25



Connector Options

952 Connector Options



Option "T"
Threaded Metal Connector
(MTS - "RB" on Tempo II & III)



Option "M"
1/4 Turn Quick Disconnect Connector
(MTS - "MS" on Tempo II & III)



Stainless Steel Head
Cover and Connector (Consult Factory)

953 Connector Options



S Connector Style
5 Pin Micro, 12mm Euro



M Connector Style
6 Pin DIN, Fits MTS D60
7 Pin DIN, Fits MTS D70 (for SSI only)



B Connector Style
8 Pin DIN, Fits Balluff S32



C Connector Style
Integral Cable Assembly



Stainless Steel Head
Cover and Connector



M Connector Style
10 Pin MS, Wired to Replace 951 and 952 LDT's

Typical Installation

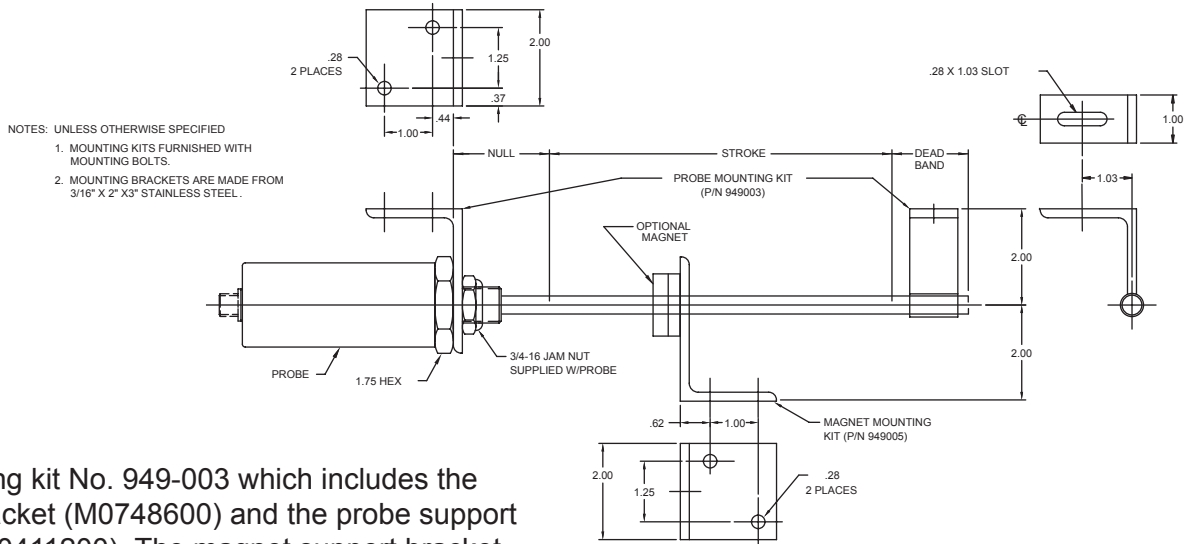

Use mounting kit No. 949-003 which includes the head "L" bracket (M0748600) and the probe support bracket (SD0411200). The magnet support bracket includes the magnet "L" bracket and hardware. It is important to use the mounting kit hardware provided, or to follow the instructions below. The magnet is sold separately. In instances where the magnet will be mounted to a ferrous surface, spacers manufactured of non-ferrous materials, such as stainless steel, nylon, etc. should be used. The spacer should be designed in such a way that any ferrous surface is no closer than 0.25" from the magnet. Ferrous material within 0.25" of the magnet will distort the magnetic flux and adversely affect the unit's operation.

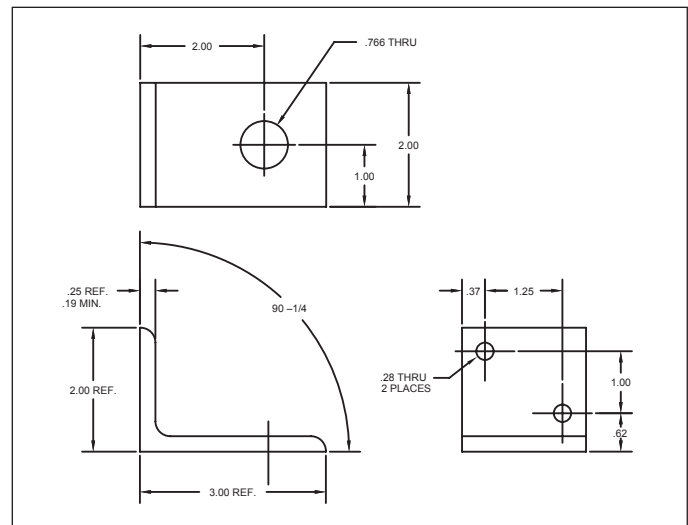
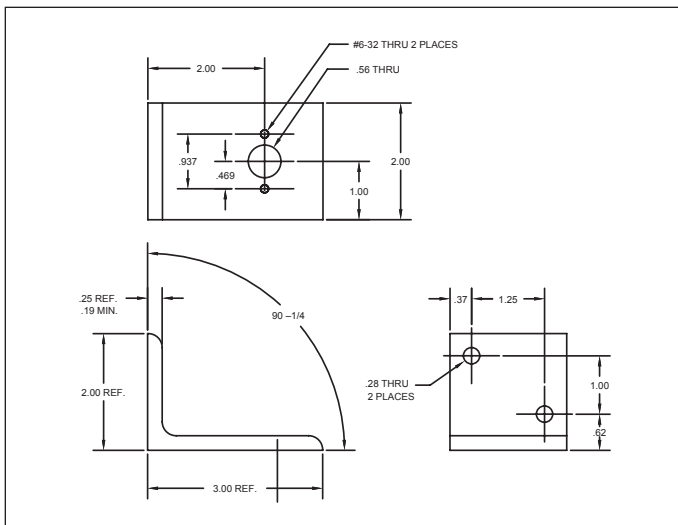
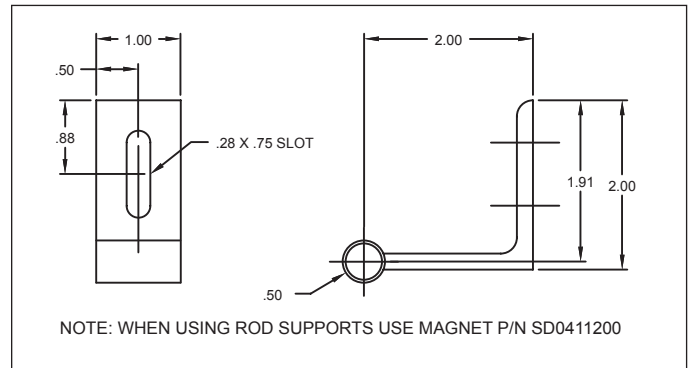

Typical Installation

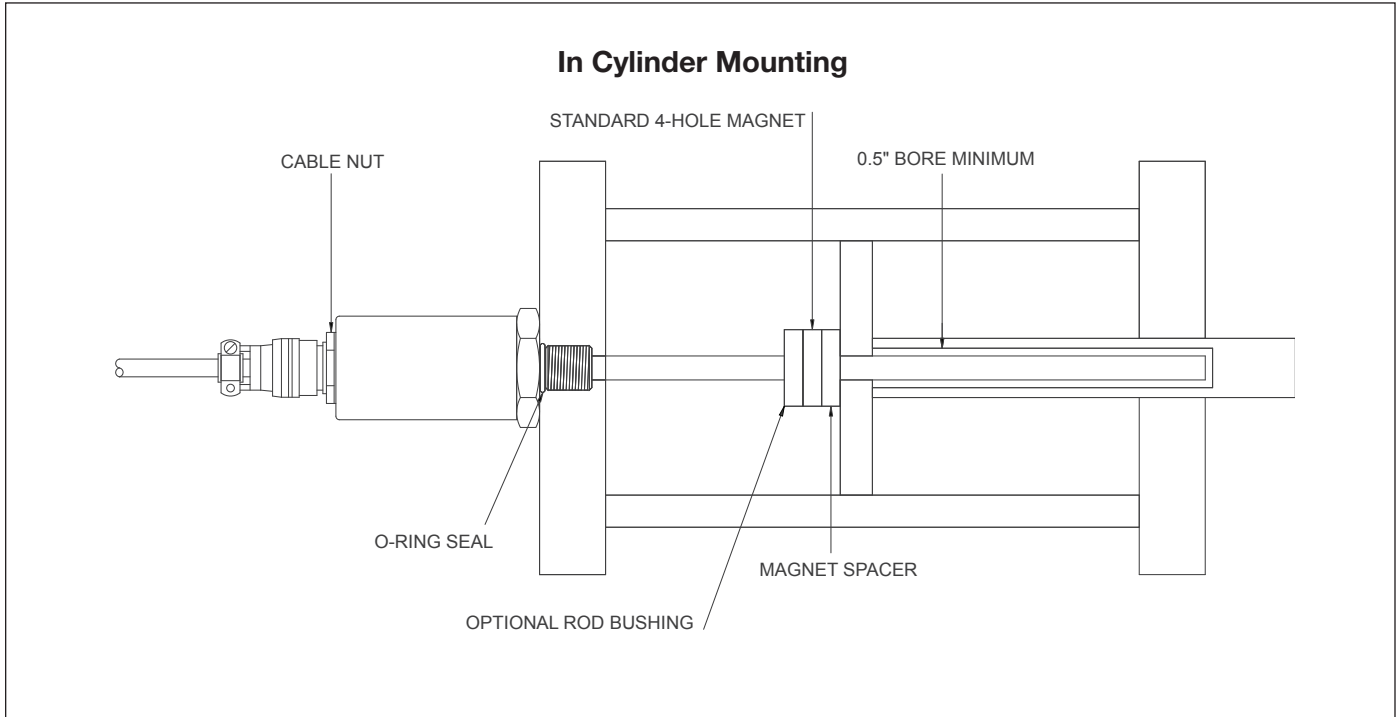

Low Profile Mounting

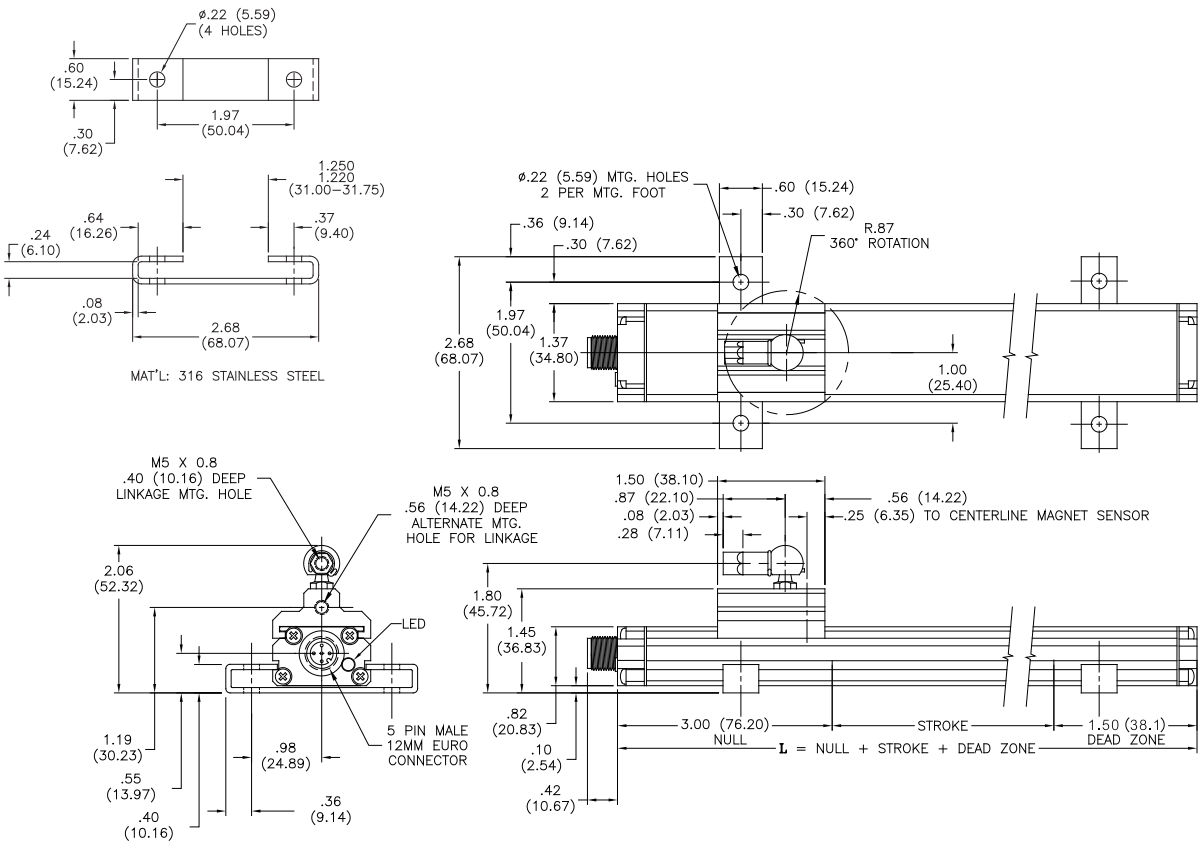

Direct Connectivity

	Series	Application	Gemco Transducer	Comments
	1746L	PLC direct input for the Allen Bradley SLC 500 Chassis	951CP, VP, RS versions 952CP, VP2, RS versions All 955D digital versions	High speed, high accuracy card that delivers position data directly to the I/O image table every 300 microseconds.
	2120	LDT input module that displays position and acts as PLC interface	951VP-2110 version when a V1 board is specified. 951, 952 or 953 CP, RS versions when an L1 board is specified	Display reads in inches or millimeters. Selectable BCD, Gray code, or Binary output. Optional analog output to indicate position and/or velocity. Optional output board provides two relay outputs.
	2110	Press shut height monitor	951VP-2110 version when a V1 board is specified. 951, 952 or 953 CP, RS versions when an L1 board is specified	Designed for press shut height. Offers programmable bolster offset, zero offset, movement direction, count direction, scale offset, and negative overshoot. Decreases hit to hit setup time and offers over-travel limits.
	1996C	Press shut height controller	951CP versions, 952CP versions, 953CP versions	Automatically adjusts the ram up or down to a pre-programmed shut height value for up to 500 jobs. Optional binary output.
	1995L (Consult Factory for 4-20 Input)	Programmable Limit Switch	955 (0-10 VDC or 4-20mA), 951A voltage versions, 952A voltage versions, 953A voltage versions	Allows the transducer to have programmable setpoints throughout the range of the sensor. This unit has multiple program capability and can expand up to 30 outputs.
	Hand-Held Programmer & PC Interface 951-1405	Allows 951 to be programmed in the field	All 951	The field programmer allows for changes in output, polarity, span, and calibration in the transducer.
	In Line Hand-Held Cable SD0457900	Allows 951 to be programmed in the field	All 951	Allows the user to plug in the hand-held programmer. In Line Hand-Held Programmer Patch Cable, use with Part Number 951-1405
	In Line Active Zone Programming Unit 955-1409	Allows 955S & 955A to be programmed in the field	952 with Connector Option S, 953A, 955A, 955e, 955S, 956A, 956S	The field programmer allows for changes in output, polarity, span, and calibration in the transducer.
	Battery Operated Test/Programming Unit SD0528810	Allows Voltage 955S & 955A to be programmed in the field	952A, 953A 955A, 955e, 955S, 956A, 956S	The field programmer allows for changes in output, polarity, span, and calibration in the transducer.
	Battery Operated Test/Programming Unit SD0528811	Allows Current 955S & 955A to be programmed in the field	952A, 953A 955A, 955e, 955S, 956A, 956S	The field programmer allows for changes in output, polarity, span, and calibration in the transducer.



Other Solutions

1025 Footswitch



- Heavy duty treadle operated foot switch
- NEMA 1 & 4
- Optional protective cover
- Single or dual circuit
- Optional locking latch kit
- Optional pneumatic valve installed in place of electrical switches

Cable & Hose Carriers



- All steel or nylon construction
- Prevents twisting & wear
- Steel withstands severe hydraulic shock loads
- Nylon resists corrosion and is non-conductive

1999 Semelex II Safetimeter



- Two Safetimeters in one; the same unit can be used to check full or part revolution clutch presses
- Rugged construction built for pressrooms; will release a run or E-Stop button to initiate press stop when signaled
- Redesigned Auto-Flag connects to the Auto-Hand and is positioned outside the sensing field or personnel safety devices
- Heavy-Duty Position/Velocity Transducer uses industrial

GEMCO Industrial Brakes



- AISE rated brakes
- Electro-Thrust shoe, magnetic DC shoe, solenoid AC shoe and hydraulic shoe configurations
- Non-Asbestos Linings
- Made in the U.S.A.

- grade magnets for secure mounting to the base and upper bolster
- Quick-Charge Battery is built in and can be fully charged in eight hours or run off AC power



LINEAR DISPLACEMENT TRANSDUCERS

PLC INTERFACE PRODUCTS

ROTARY POSITION PRODUCTS

PROGRAMMABLE LIMIT SWITCHES

EXTREME DUTY CABLE REEL PRODUCTS

ROTARY LIMIT SWITCHES

RESOLVERS

MILL DUTY ENCLOSURES

ULTRA HIGH SPEED PLS

SAFETY PRODUCTS



MADE IN AMERICA

Copyright © 2013 by AMETEK Inc. All Rights Reserved. Made in the USA.