

AMETEK®

GEMCO

The Series 2500

A New Family of Programmable Limit Switches

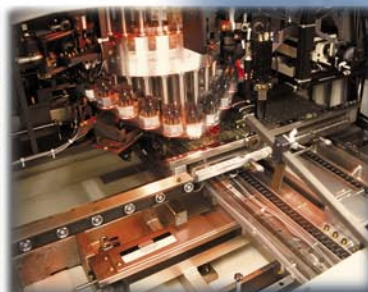



SPEED

Higher speed means greater productivity, with a 100 microsecond scan. The Series 2500 is typically 100 times faster than PLC's.

FLEXIBILITY

From 8 - 64 inputs and outputs are available. This can be obtained by using a simple panel mount with on board relays or a remote display and DIN Rail mount controller. The update speed is the same regardless of the number of outputs.



SIMPLICITY

The Series 2500 PLS is extremely simple to program. The scroll knob is used to cycle through the real language display. A help menu eliminates operator confusion.

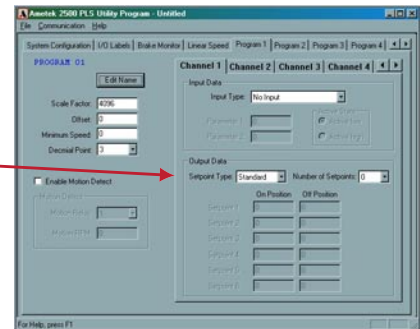

As an added bonus, a Windows-based programming file allows full upload and download of all program parameters via the RS485 communication port. For the OEM, this means rapid downloading of all programs and setpoints for a given machine. For the user, this feature is a permanent record and back-up of proper machine setting.

Scale Factor

The scale factor is the number of increments that the PLS counts through during one rotation of the resolver. For example, a PLS based on a scale factor of 360 will count from 0 to 359 over one revolution. Valid values that can be programmed for the scale factor are 2-65535.

Offset

The offset feature is used to electronically synchronize the PLS displayed position with the actual machine position.

Supervisor Menu

Two levels of programming access are provided: User and Supervisor. In the supervisor menu, display screens can be customized and outputs and functions can be locked out. Each level can be assigned a password that must be entered to program the locked out functions. This can provide key personnel the flexibility they need while protecting settings against accidental or unauthorized changes.

On Board Help

On board help is available from the vacuum fluorescent display. Each programming screen has easy-to-follow English instructions and help screens.

Multi-program

The multi-program feature allows the storage of multiple sets of output sequences that are pre-programmed based on various requirements of different jobs. When jobs are changed, the new program is simply called up from the interface or remote inputs and all outputs and inputs are automatically set to the new output sequences. The 2500 PLS is capable of storing 15 different programs.

Program Name

The program name feature allows the user to assign alphanumeric names up to 15 characters for each program.

Program Copy

The program copy feature can be used to copy all operating parameters from one program to another. This is useful when there are small variations from program to program.

Brake Monitor

The brake monitor checks the stopping time of the machine against a selectable stopping time. A user defined output remains energized when the stop time parameters are within tolerance. An excessive stop time will cause the relay to de-energize, which could be used to stop further machine operation.

Motion Detector

A programmable motion detect output will energize a relay when the resolver speed meets or exceeds the programmed RPM value.

Fault Check

The 2500 PLS offers an on board fault check which provides an automatic, in-process mechanism to verify that all major programmable limit switch functions are operating properly. The fault check output can be energized by activating the fault check enable input. The output is a mechanical relay which remains energized during normal operation.

Input Configuration

Each input can be configured as either a reset to preset input, an output enable input, or a die protection input.

Reset to Preset

The reset to preset features allow the user to reset an output to any pre-programmed position. This feature can be used to compensate for mechanical slippage.

Note: each output has its own independent reset input.

Reset to Preset Single Shot

The reset to preset single shot features allows the user to reset an output to any pre-programmed position. However, with this feature the output associated with this input waits for the input signal before it allows the output to fire. Once the input is made, the output will only fire for one resolver rotation before waiting for the next input signal.

Die Protection

Die Protection is used in stamping applications where it is necessary to monitor a part as it is progressing through the die. If the part is not detected in the proper location, an output will signal the press to stop.

Output Enable

Output Enable is used in conjunction with an input. If the input is not seen within the user programmed range, the output associated with that input will not fire. Output enables are typically used in gluing applications where the gluing output does not fire if a product is not present.

Setpoint Data

There are six setpoint pairs that can be programmed for each output. The user can add, delete, or change a setpoint in the list. Valid setpoints range from 0 to a value one less than the current scale factor. For example, if the scale factor is set at 1000, then valid setpoint values range from 0 to 999.

Timed Outputs

Time based outputs are programmed like standard outputs to turn on at a specific resolver position and turn off according to time.

Minimum Speed Disable

The minimum speed disable will disable the selected outputs when the actual RPM falls below the minimum speed programmed by the user. Valid minimum speed values range from 0 to 2048. A value of 0 will disable this feature.

Linear Speed Compensation

Speed compensation allows for setpoints to be adjusted based on the RPM value. Each output can be programmed with its own adjusted values. The user will program an on offset and an off offset and the RPM that is associated with that offset. The unit will linearize the offset values and adjust the setpoints for that output based on the actual RPM value.

Labeling Inputs and Outputs

User defined names can be assigned to inputs and outputs.

RS 485 Communication Port

This communication port is used for upload and download through an optional Windows based program and offline programming. This port also supports the Modbus ASCII protocol and can interface to many HMI's as a slave device.

Remote Operator Interface, Blind Main Controller and Expansion Module

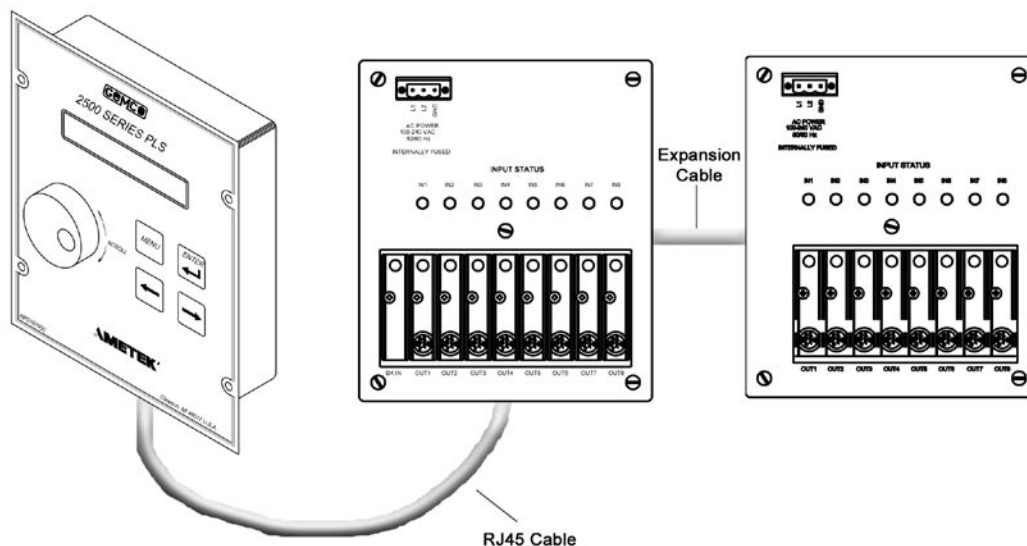

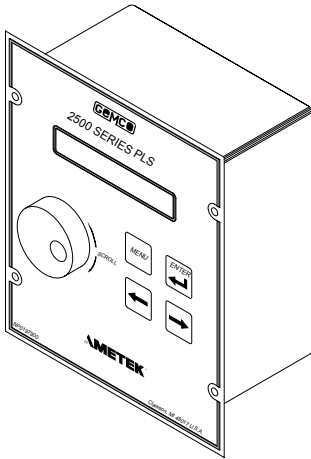

2500 Stand Alone Main Controller

- 8 Isolated DC Inputs and 8 Solid-State AC or DC Outputs, or Mechanical Relays, Expandable to 64 (in groups of 8) using 2500E Expansion Modules
- Brake Monitor
- 2 x 24 Vacuum Fluorescent Display
- Panel Mountable
- Rotary Knob, with Scrolling, Menu Driven Programming

The main controller is resolver-based and consists of 8 isolated DC inputs and 8 isolated output relays, one fault check output relay and one optional brake monitor input relay. The main controller unit can be ordered as either a complete stand alone system or as a blind unit for use with the 2500R Remote Operator Interface.

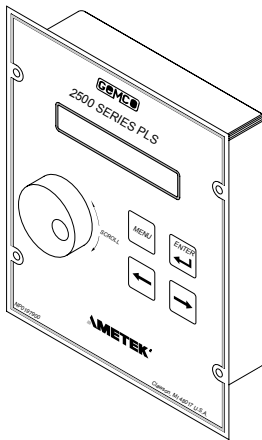

2500R Remote Operator Interface

- Keypad Only, Used with 2500C Blind Main Controller Units
- 2 x 24 Vacuum Fluorescent Display
- Panel Mountable, up to 25 Feet From Main Controller
- Simple RJ45 Connections to Main Controller
- Rotary Knob with Scrolling, Menu Driven Programming

The Remote Operator Interface is made up of a 2x24 vacuum fluorescent display along with 4 pushbutton keys and a rotary knob for programming. The keys have been defined as MENU, ←, →, and ↵. The 2500R Remote Operator Interface is used with the 2500CB main controller units to remotely program the main controller.

- A rotary knob replaces the standard number buttons. As the knob is rotated it scrolls through the programming process. The entire programming process is accompanied by convenient Help screens.
- A 2 line x 24 character vacuum fluorescent display shows all PLS functions.
- The Remote Operator Interface connects to the main controller through an 8 pin Ethernet cable, commonly know as an RJ45. Full duplex RS-485 is used to communicate to the main controller.

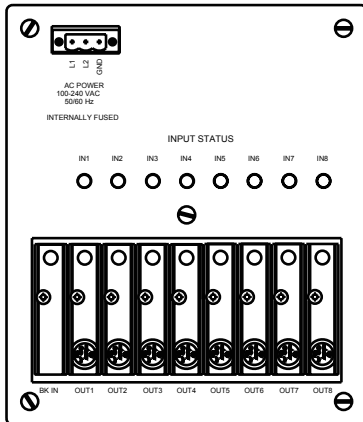

2500C Blind Main Controller Units

- 8 Isolated DC Inputs and 8 Solid-State AC or DC Outputs, or Mechanical Relays. Expandable to 64 (in groups of 8) using 2500E Expansion Modules
- Brake Monitor
- Panel or DIN Rail Mountable

Incorporates the same functionality as the stand alone unit.

NOTE: The Remote Operator Interface is typically used with this unit, however it can connect directly to an HMI using the Modbus ASCII protocol.

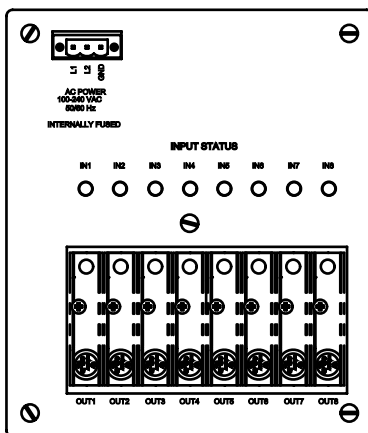

2500E Expansion Modules

- 8 Isolated DC Inputs and 8 Solid-State AC or DC Outputs or Mechanical Relays
- Panel or DIN Rail Mountable
- Up to 7 Expansions Modules can be Driven From the Main Controller
- Simple Depluggable Connections from Expansion to Expansion

The standard 2500 PLS is supplied with 8 inputs and 8 outputs. The system is expandable to 64 inputs and 64 outputs by adding the 2500E Expansion Module. Each expansion module consists of 8 outputs and 8 inputs. These outputs are an optically isolated barrier between the PLS and the field devices they control. These output modules are also de-pluggable and can be configured with any combination of AC and DC or mechanical relays.

- Panel mount or DIN rail mountable.
- Plug and play cable design.
- Pluggable output relays.
- No increase in update time regardless of number of expansion modules.
- LEDs are located next to each input and output. These LED's specify the state of each input and output.

SPECIFICATIONS

Resolution:	12 Bit (4096)
Scale Factor:	2 - 65535
Scan Time:	100 Microseconds, Regardless of Number of Output Channels
Input Voltage:	100 - 240VAC 50/60Hz
Power Consumption:	7 Watts
Max. Speed:	2048 RPM
Job Storage:	Up to 15 Programs
Temperature Range:	Operating: 32 - 131°F (0 - 55°C) Storage: 0 - 150°F (-17 - 65°C)
Resolver Cable Length:	1000 ft. max.
Enclosure Rating:	IP50

Output Relays

DC Relays

Output relay type G4ODC5
5-60VDC, 3amp max. load
1ma leakage current @ 60VDC
50 microsecond turn-on and turn-off time

AC Relays

Output relay type G4OAC5A
24-280VAC, 3amp max. load
1.25ma leakage current @ 120VAC
2.5ma leakage current @ 240VAC
8.3 millisecond turn-on and turn-off time, one-half cycle maximum. Relay turns on at zero volt crossing of the AC sine wave.

Mechanical Relays

S.P.D.T. 8 amps, 250 VAC, 30 VDC, 1/4 HP 125, 250 VAC

Inputs

8 Isolated Inputs 10 - 30 VDC,
Sourcing Device ON @
>1.5mA @ 10V
>4.0mA @ 30V

Program, Fault Clear, Multi-Program Inputs

Sinking Inputs +5VDC max.
On @ <1Vdc @ 5mA

2500CF Stand Alone Main Controller Dimensions

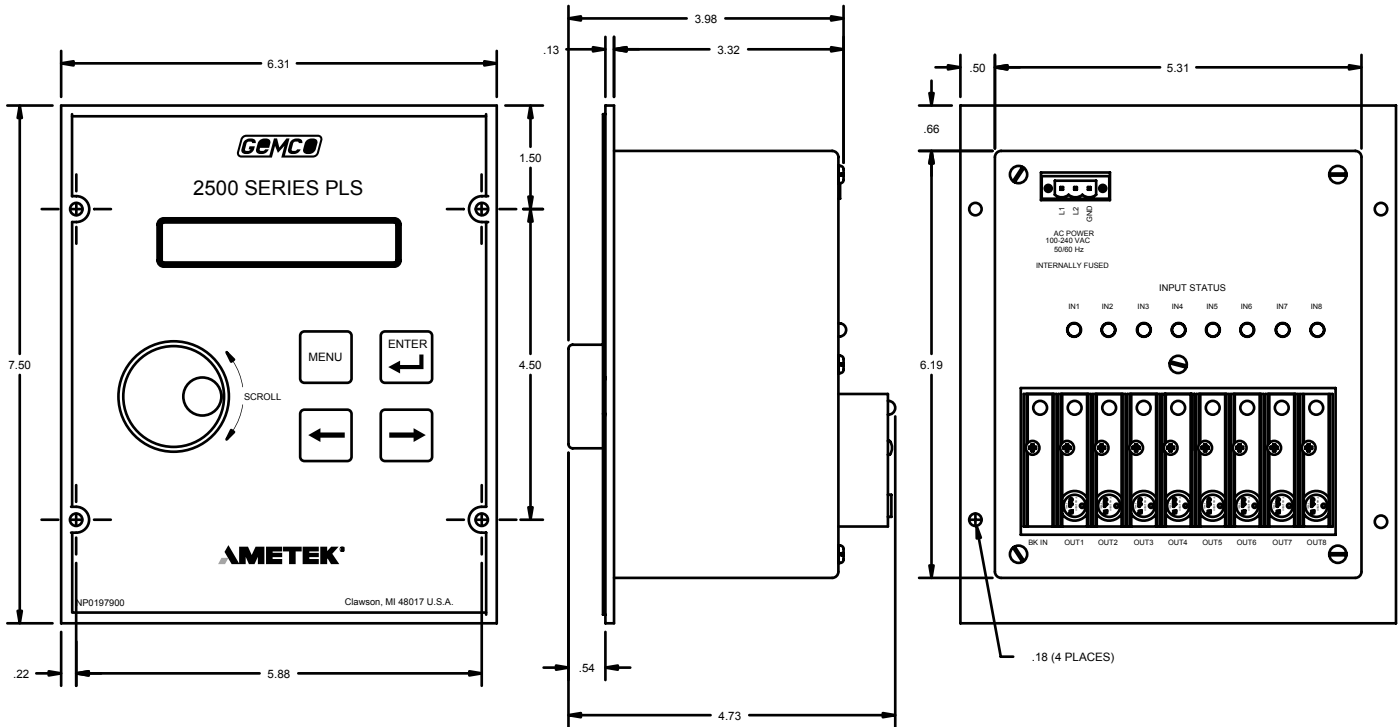

2500R Remote Operator Interface

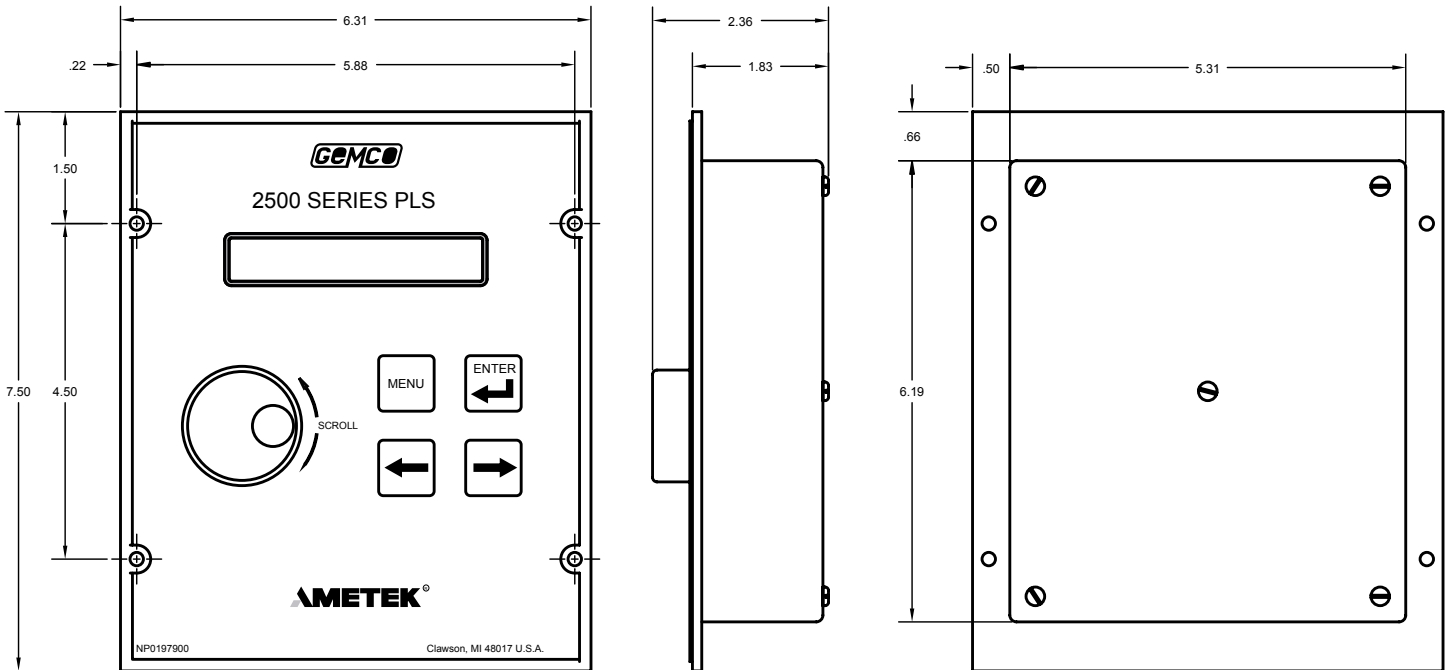

2500CB Blind Main Controller Unit

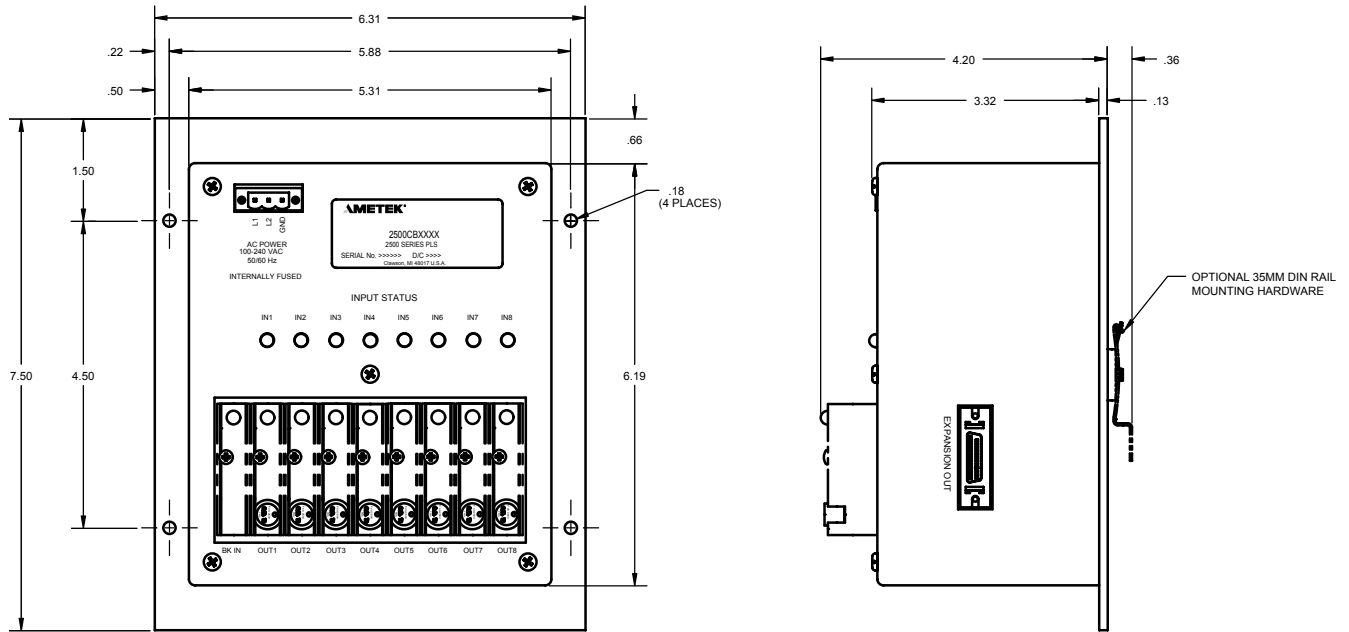

2500E Expansion Module

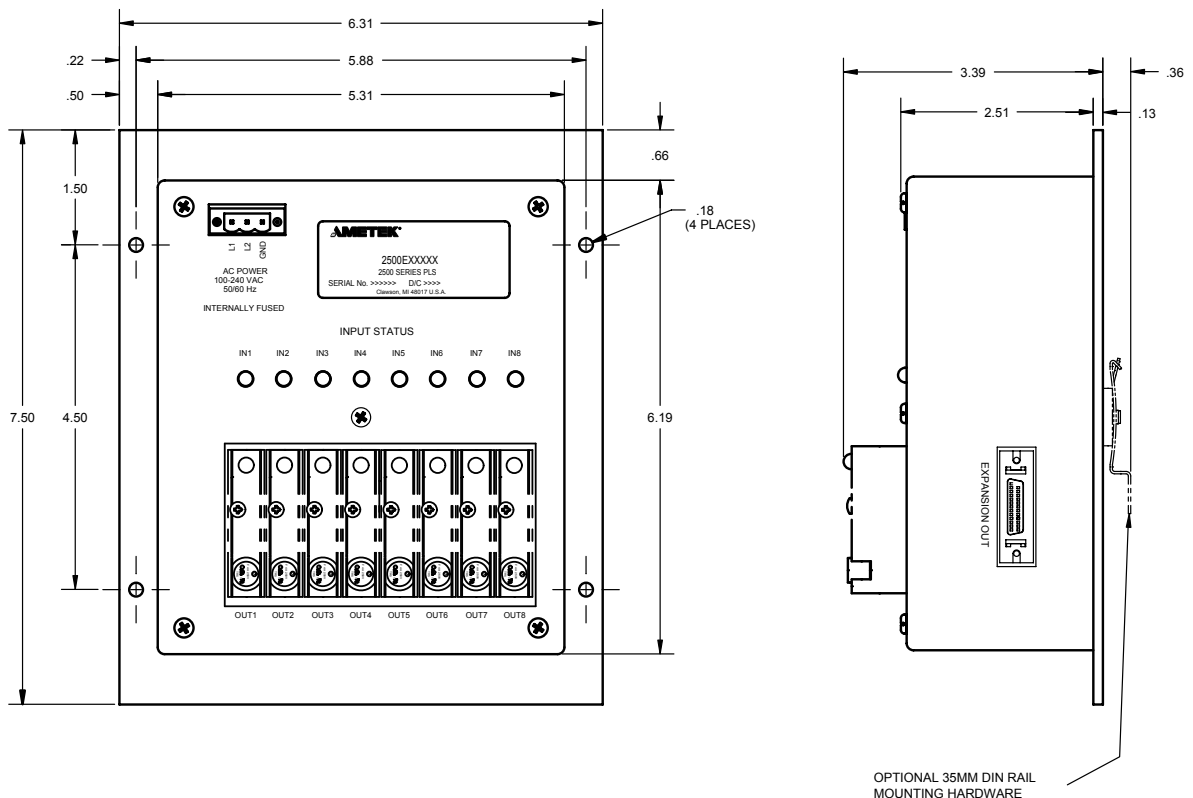

Nema 4 & 12 Enclosure (Option 4 or 12)

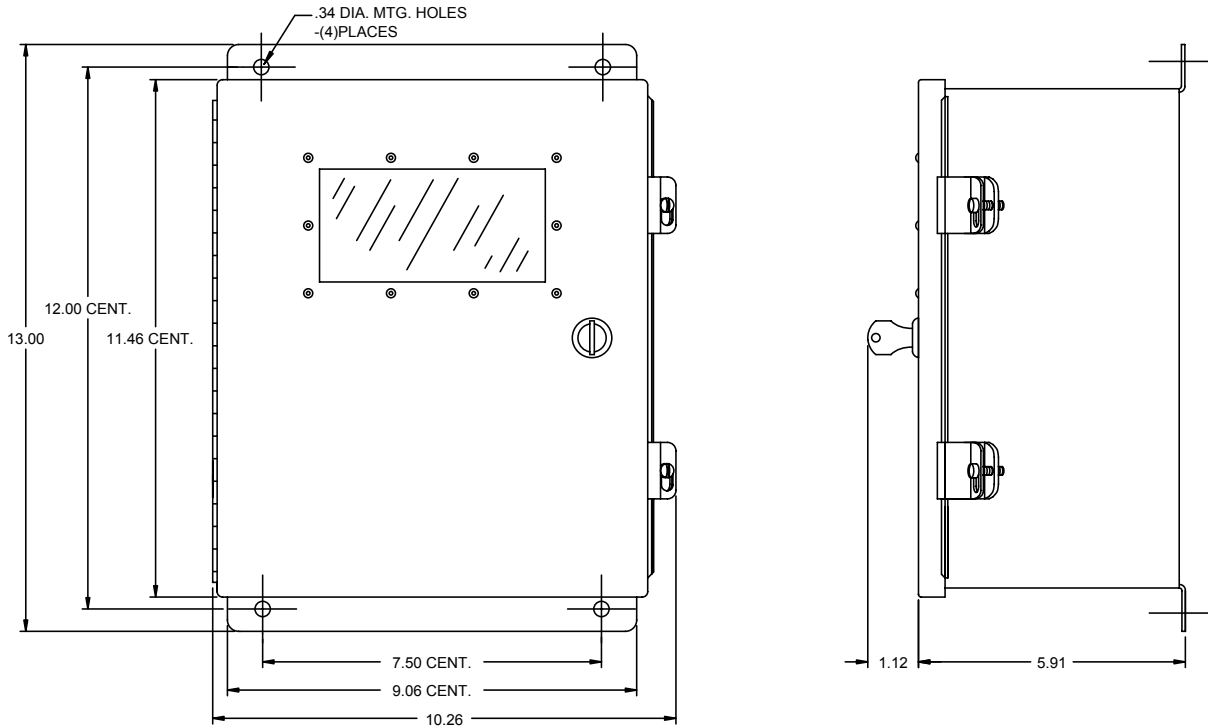

Nema 4 with 2 Expansion Modules (Option 4A)

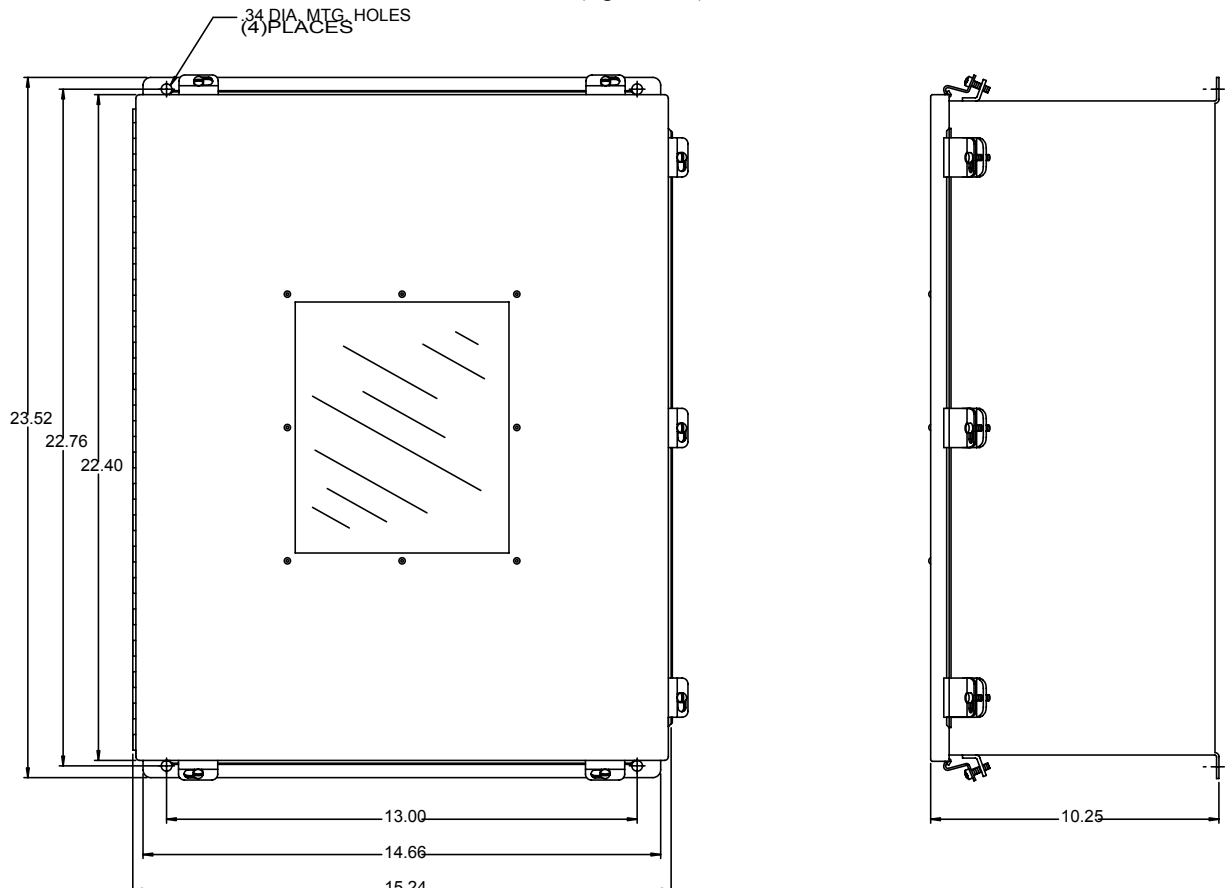

Nema 12 with 2 Expansion Modules (Option 12A)

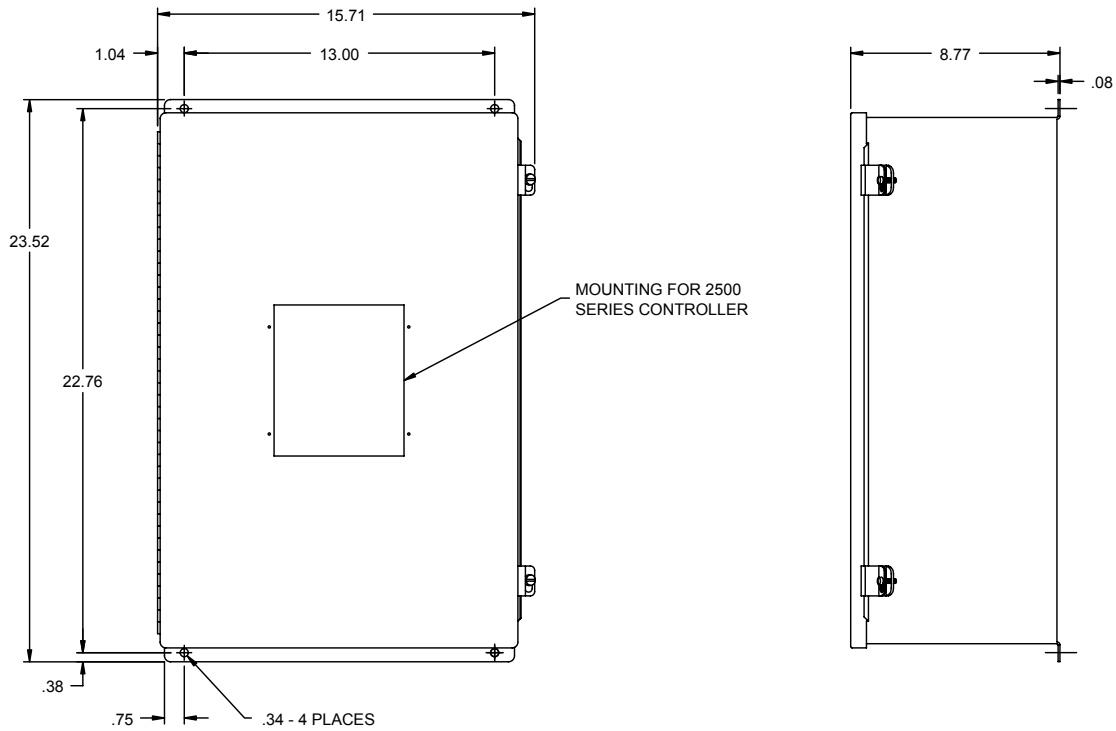

Nema 12 with 4 Expansion Modules (Option 12B)

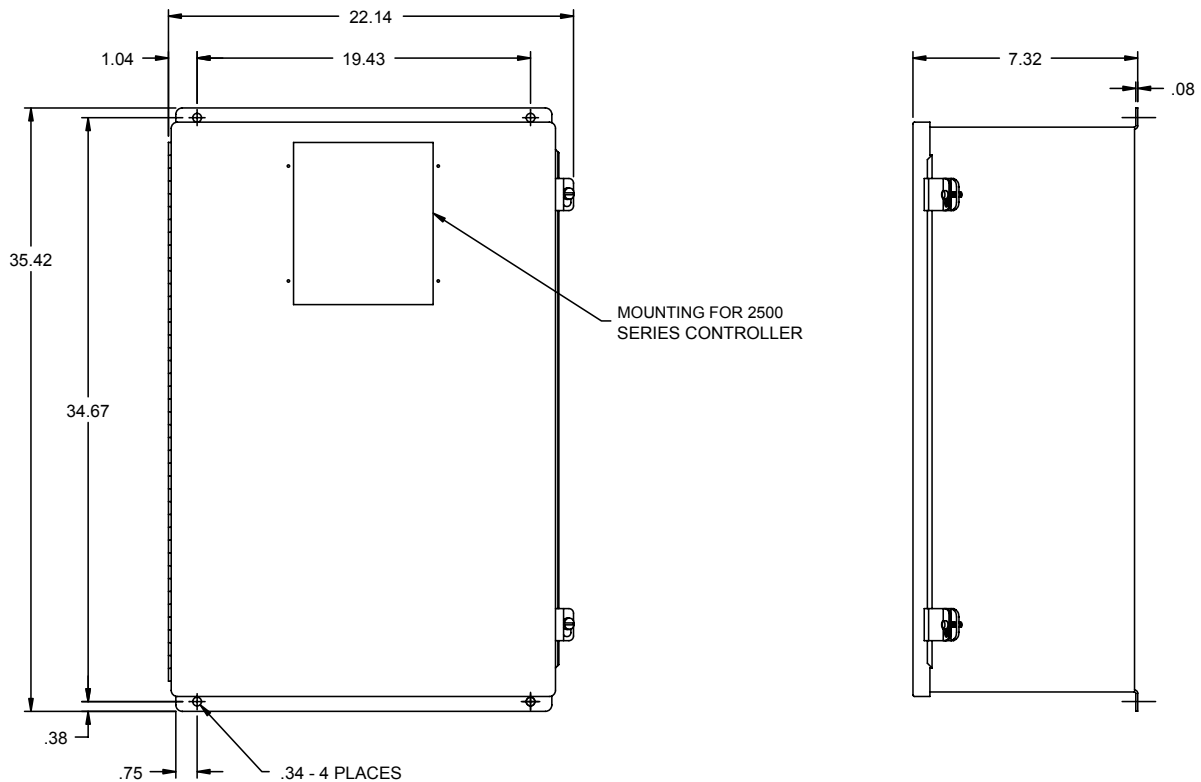

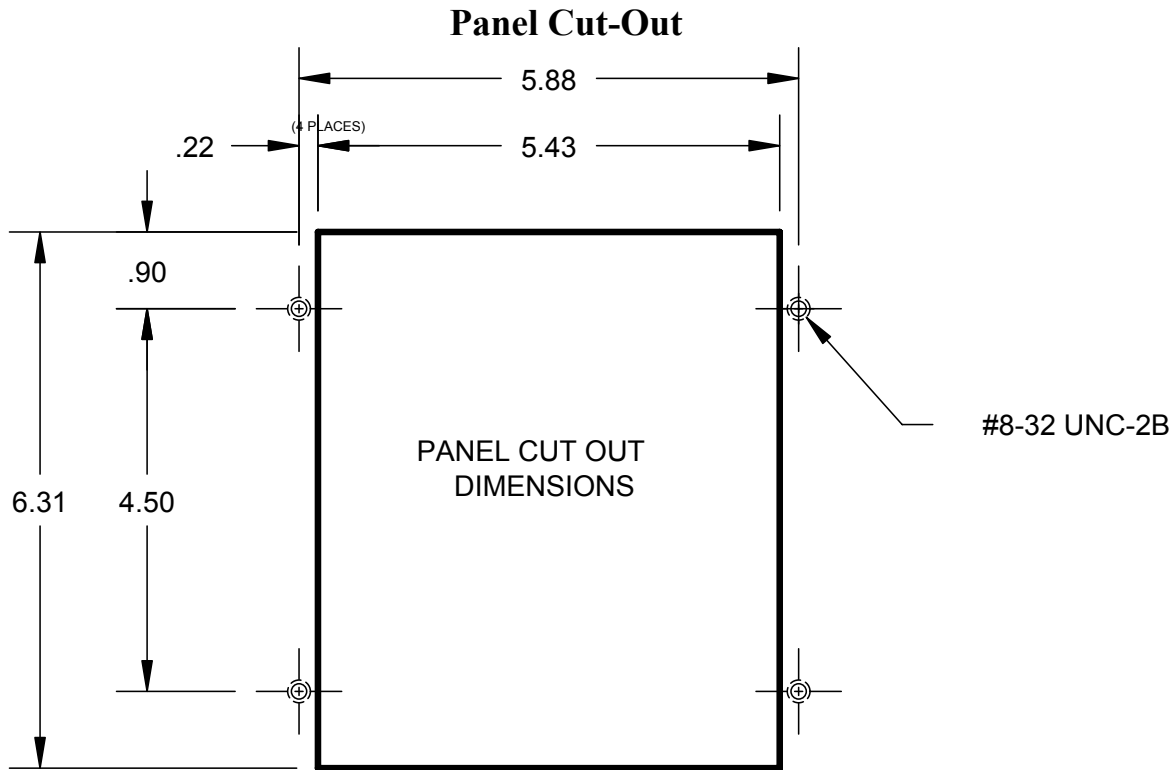

Cut-out dimensions for the Series 2500CF, 2500CB, 2500E and 2500R

1986F Resolver

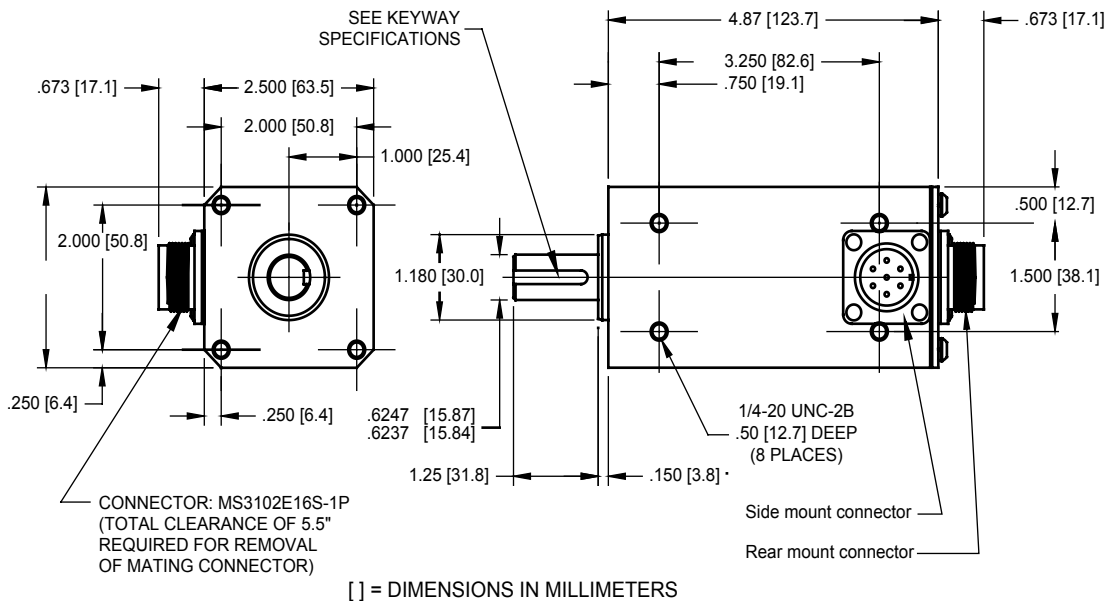

Resolver Cables	
Part Number	Description
SD0508200L15	Resolver Cable - Straight Connector (15 ft.)
SD0531400L15	Resolver Cable - Right Angle Connector (15 ft.)
SD0296000	7 pin Straight Resolver Cable Connector
SD0370200	7 pin Right Angle Resolver Cable Connector
01-533114L_	22 awg, 3 Twisted Pair Resolver Cable with Shield
Cable length in feet is required at the end of the part number. Maximum cable length is 1,000 ft.	

Resolvers	
Part Number	Description
1986F-1-X-R-X	Industrial Duty Block Mount Resolver
PSD0232100	Resolver Mounting Bracket for 1986 "F" Style Resolver
See Catalog Section 1986 for Full Line of Gemco Resolvers	
See Catalog Section 1980R for Combination Camswitch/Resolver Assemblies	

The Series 2500 is a family of PLS's that offers unparalleled flexibility. The main controller is resolver-based and consists of 8 isolated DC inputs and 8 isolated output relays, one fault check output relay and one optional brake monitor input relay. Each optional expansion module will provide 8 additional inputs and 8 outputs per module. Up to 7 expansion modules can be driven by the main controller for a total of 64 inputs and 64 outputs. The display and keypad, known as the Remote Operator Interface, can be remotely mounted when desired.

2500 Main Controller

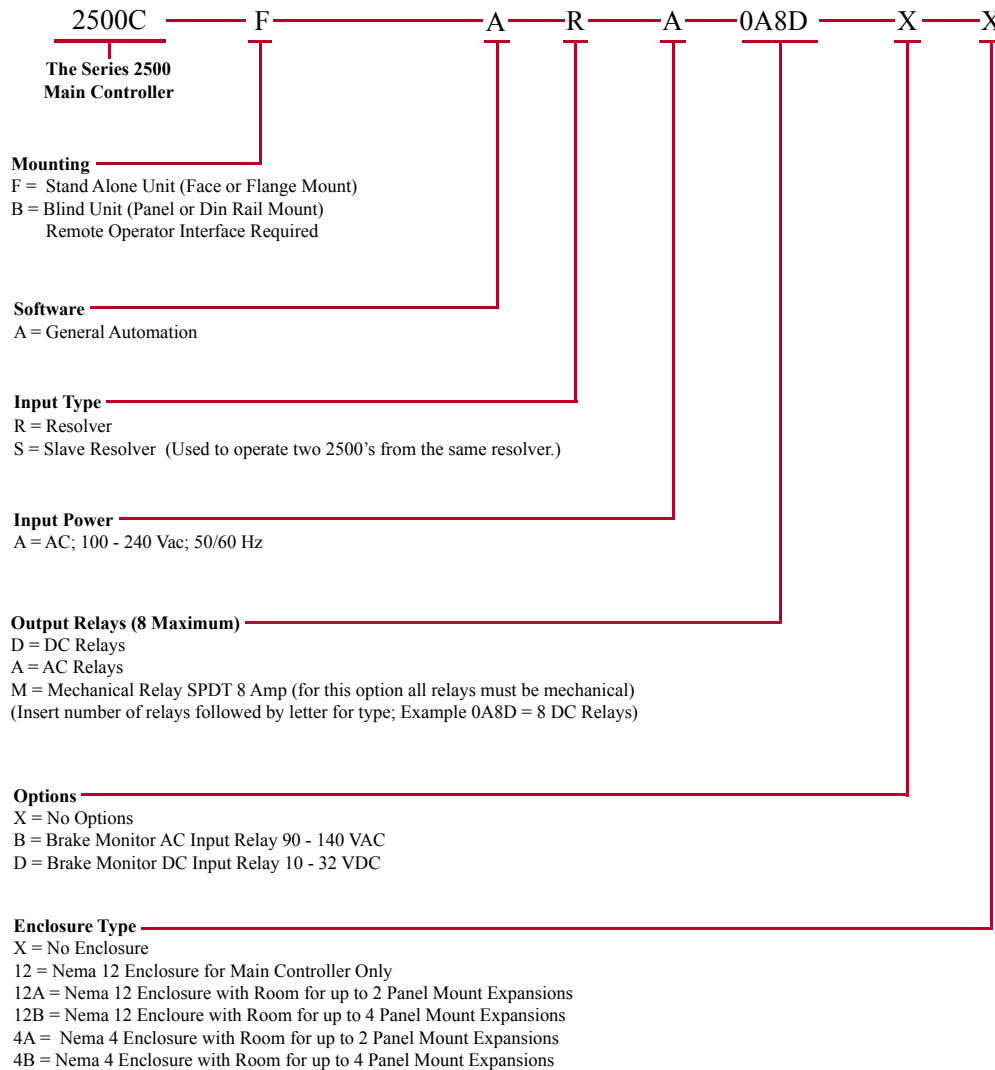

Spare Relays	
Part Number	Description
04-523125	Solid-State AC Brake Monitor Input Relay, 90 - 140 VAC
04-523133	Solid-State DC Brake Monitor Input Relay, 10 - 32 VDC
04-523126	AC Solid-State Relay, 3 AMP, 24-280 VAC
04-523127	DC Solid-State Relay, 3 AMP, 5-60 VDC
04-523083	S.P.D.T. Mechanical Relay 8 Amp

2500 Expansion Module

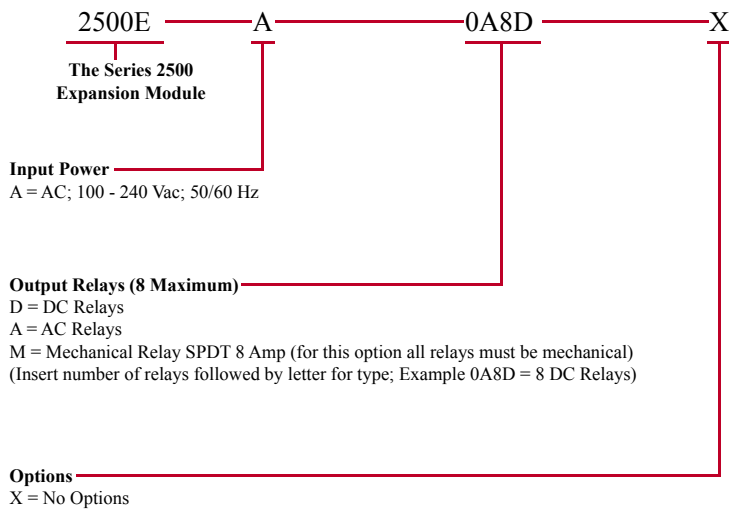

Expansion Module Cables	
Part Number	Description
SD0528500L1	1 ft. De-Pluggable Expansion Cable
SD0528500L2.5	2.5 ft De-Pluggable Expansion Cable
SD0528500L6	6 ft. De-Pluggable Expansion Cable

2500 Remote Operator Interface

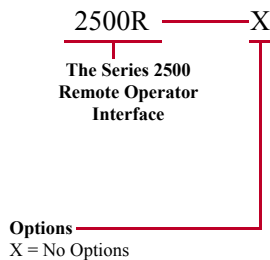

* The 2500R is only used with th 2500CB Blind Main Controller Unit.

Remote Operator Interface Cables	
Part Number	Description
SD0530100L6	6 ft. RJ45 Cable
SD0530100L9	9 ft. RJ45 Cable
SD0530100L22	22 ft. RJ45 Cable



Positioning Solutions for Niche Markets...

In addition to the products **AMETEK Automation & Process Technologies** provides the packaging industry, we also offer positioning solutions to a wide variety of niche markets. Whether you're looking for rotary positioners, linear displacement transducers, resolvers, switches, brakes, or safety devices, AMETEK APT has a solution for your application. From PLC cards to mill duty sensors, you'll find our products across a myriad of industries, including:

- Plastics** — injection molding and extruding, vibration and spin welding
- Mills** — steel, paper, and lumber
- Machine Tools** — robotics, stamping, transfer presses, casting, automated conveying
- Nonwovens** — diapers and feminine hygiene products
- Textiles** — looms and weaving
- Chemical** — liquid level
- Food and Pharmaceutical** — liquid level and packaging

■ ***Safety Devices, Switches, and Brakes***

Some of our products are so well designed and versatile that they defy classification. From PLC cards to footswitches to a broad selection of stopping and holding brakes, **AMETEK Automation and Process Technologies** has been solving production problems for years. Whether you are operating a crane or producing baby diapers, we have a wide assortment of **Gemco** products to help optimize your processes.

■ ***Programmable Limit Switches***

Whether your need is a dedicated, ultra-high speed control to manage the complexities of packaging, converting, or gluing applications, or something as slow-paced as controlling basic input/output and shut height on a stamping press, a Gemco Programmable Limit Switch (PLS) has just the right stuff. With features specifically designed for these industries, our PLS product line offers world-class value for firms that need the speed, flexibility, or ease-of-use that Gemco PLSs are known for.

■ ***Network Connectivity***

The seamless passing of information from the production line to the people who need it requires smart processes. Gemco's 'connected' products include a wide array of linear displacement transducers (LDTs), resolvers, and PLSs that transparently make available vital process information without interrupting the flow of production. From **DeviceNet™** to **ControlNet™** we are the home of smart, rugged sensors that speak your language.



We Are Your Solution to Factory Automation...



GEMCO

AMETEK[®]
AUTOMATION & PROCESS TECHNOLOGIES

1080 North Crooks Road • Clawson, MI 48017 USA
800-635-0289 • 248-435-0700 • 248-435-7540
www.ametekapt.com www.ametek.com

2500.B1R2
1/04.Z143
3M