



1025C Foot Switch Service Bulletin

Heavy Duty, Treadle Operated

Description

This treadle-operated foot switch has two precision unit switches. Each of these has a normally open and a normally closed circuit. The switch, as shipped, is set up for three-position spring return of the treadle lever. The cam block may be rotated to provide either two- or three-position maintained contact. See back side for Cam Positioning instructions.

Installation

This foot switch may be mounted in any convenient position. When installed, it will give a long service life with a minimum amount of maintenance. Four stamped function nameplates are included with the switch: "Start," "Stop," "Forward," and "Reverse." Mount the two plates which best suit the application.

Adjustment

This switch does not require adjustment or readjustment.

Renewal Parts

When ordering renewal parts, give this Document No. Z74, Item No., Description, Quantity, Part No., and the Complete Number stamped on the label.

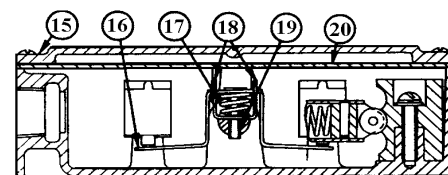
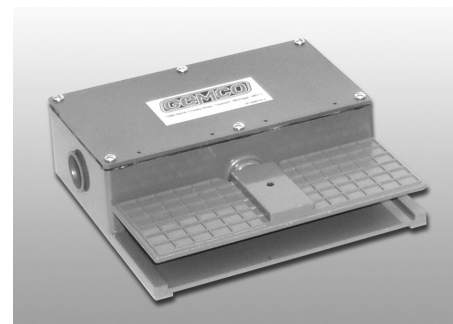
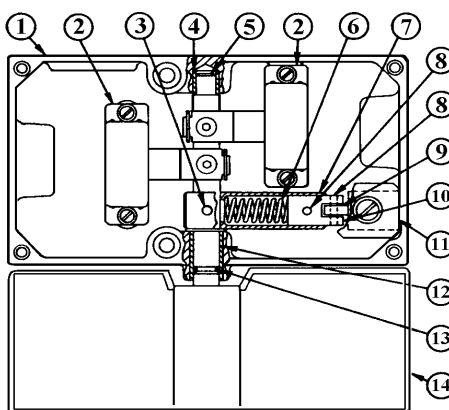

Renewal Parts			
Item No.	Description of Part	No. Req.	Part No.
1	Case Complete (Includes items 4 and 12)	1	SD0316900
2a	Switch - SPDT	As Req.	1950-1-B-A-D0
2b	Switch - DPDT	As Req.	1950-4-B-A-D0
2c	Air Switch	As Req.	04537014
3	Pin	2	04564030
4	Bearing	1	04570018
5	Shaft	1	M0651400
6	Spring	1	04581006
7	Sleeve	1	M0651600
8	Spring pin 5/32" dia. x 1/2" long	2	04564031
9	Roller	1	M0667100
10	Plunger	1	M0651800
11	Cam Block	1	P0078800
12	Bearing	1	04570019
13	Sealing Washer	1	04563034
14	Treadle Level	1	A0054400
15	Cover Complete (Includes item 20 and cover screws)		
	With Shield	1	SD0317600
	Without Shield	1	SD0316800
16	Lever	As Req.	C0743400
17	Spring	As Req.	04581004
18	Bracket	As Req.	S0070200
19	Flat Head Screw #10-32 x 7/8"	As Req.	04560062
20	Gasket	1	S0069200

1025C Heavy-Duty Foot Switch

Dimension Drawing

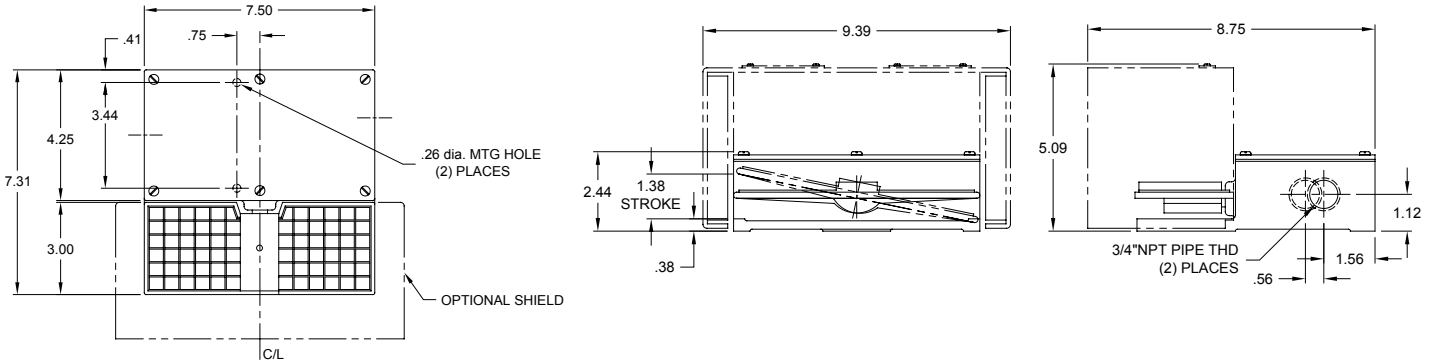

Cam Positioning

Item 11 (Fig. 1 and Fig. 2) illustrates the three available cam faces that control the treadle positions. When the switch leaves the factory, the cam is assembled for three-position spring return. This is shown on the left face of Figure 1. The right face of Figure 1 is for two-position maintained contact. The left face of Fig. 2 is for three-position maintained contact.

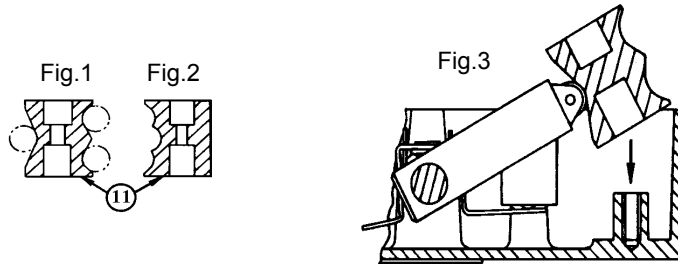

To Change Cam Positions

(Fig. 3) Remove the screw in the center of the cam block. Lift the cam block straight up. Allow the cam follower to rise with the block. When the cam block is up as high as it will go, tip it as shown in Fig. 3 and remove. Turn the cam block to provide the desired face as described on Cam Positioning paragraph above. Install the cam block observing the procedure described above.

SPDT
SINGLE POLE
DOUBLE THROW

FILE E56660
CCN NKCR2

DPDT
DOUBLE POLE
DOUBLE THROW

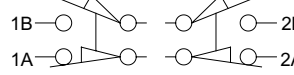
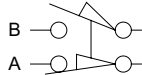
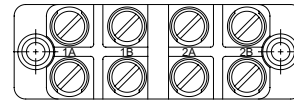
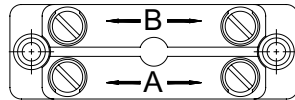

CONTACT RATINGS AMPERES

AC Pilot Duty			DC Pilot Duty	
Volts	Make	Break	Volts	Make/Break
110	40	15	115	0.25
220	20	10	230	0.10
440	10	6	600
600	8	5		

CONTACT RATINGS AMPERES

AC Pilot Duty			DC Pilot Duty	
Volts	Make	Break	Volts	Make/Break
115	30	3	115	0.2
230	15	1.5	230	0.1
440	7.5	.75	600
575	6	.60		

APPLICATION NOTE

- The N.O. and N.C. contacts of the SPDT snap switch must be used on circuits of the same polarity.
- The DPDT snap switch has (2) two electrically separate poles, which can be used on opposite polarities. The N.O. and N.C. circuit of each pole of the DPDT snap switch, however, must be used on the same polarity.

Lubrication

This limit switch was lubricated at the factory and should not require lubrication for the life of the switch.

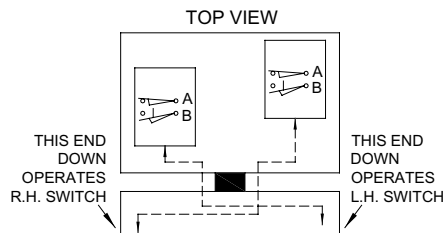

OPERATOR WARNING

THIS FOOT SWITCH SHOULD ONLY BE USED WHERE POINT OF OPERATION GUARDING DEVICES HAVE BEEN PROPERLY INSTALLED SO THAT IT IS IMPOSSIBLE FOR THE OPERATOR'S HANDS OR FINGERS TO REMAIN WITHIN THE POINT OF OPERATION DURING THE ACTUAL MACHINE CYCLE.

OSHA REGULATIONS (STANDARDS 29 CFR - 1910)

NP-0096900