



**Interface Manual**

**Continuous Level Controls**

# **7100 Leak Detect Stik™**

**MAGNETOSTRICTIVE LEVEL SYSTEM**

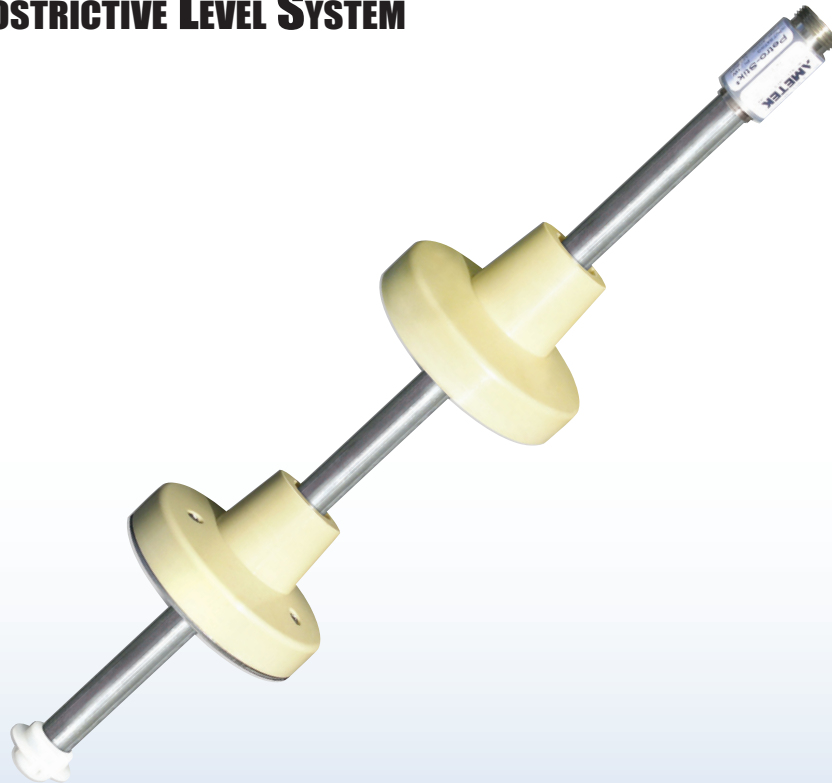

**ABSOLUTE PROCESS CONTROL  
KNOW WHERE YOU ARE... REGARDLESS**

**AMETEK®**



# Contents

<b>Chapter 1: Description of Probe</b> .....	<b>2</b>
1.1 Data Protocol .....	2
1.2 Frame Protocol .....	3
1.3 Installation and Dimension Drawings .....	5
<b>Chapter 2: Interfacing to Probe</b> .....	<b>8</b>
2.1 Interface Hardware .....	10
<b>Chapter 3: Getting the Data</b> .....	<b>12</b>
3.1 Synchronizing with a Watchdog Timer .....	12
3.2 System Hardware Setup .....	12
3.3 System Software Setup .....	13
<b>Chapter 4: Processing the Data</b> .....	<b>14</b>
4.1 Front End Algorithm .....	14
<b>Chapter 5: Computing the Temperature</b> .....	<b>15</b>
5.1 Improving Measurement Accuracy .....	15
EC Certificate of Conformity .....	18

AMETEK has checked the accuracy of this manual at the time it was printed. Any comments you may have for the improvement of this manual are welcomed.

AMETEK reserves the right to revise and redistribute the entire contents or selected pages of this manual. All rights to the contents of this manual are reserved by AMETEK.

The information in this document is subject to change without notice. No part of this document may be reproduced or transmitted in any form or by any means, for any purpose, without the express written permission of AMETEK.

# Chapter 1: Description of Probe

The 7100 liquid level probe uses a proprietary data transmission technique providing a compact information format for level and temperature data, and a signal pattern which is very easily recognizable at the console.

## 1.1: Data Protocol

Transmission consists of a sequence of similarly formatted frames of data, each frame in turn, consisting of 15 pulse pairs and a pause period. The pause period, as well as the 15 pulse pairs, each occupy 1 of 16 equal time slots of approximately 4.5 milliseconds<sup>1</sup>.

Time slot #1 is the pause period and carries no signals. This pause is used by the console to synchronize with the signal sequence. After this pause is found, no further recognition operations are necessary; the console can simply follow the sequence described below. Each of the remaining 15 time slots carries two pulses. The time interval between the pulses in each pair is equal to a value of the parameter assigned to the corresponding time slot. (See Figure 1)

Even numbered pulse pairs #2, 4, 6, 8, 10, 12, 14, & 16 carry temperature related data.

The time interval between the pulses in time slot #3 is proportional to the water level (the lower float position).



The six remaining odd numbered pulse pairs #5, 7, 9, 11, 13, & 15 carry signals related to the product signal. Thus, information on the product level collected during one frame increases the initial resolution (determined by the frequency of the clock advancing the high speed counters in the console) by a factor of about 2.5 (square root of 6). See footnote<sup>2</sup>.

The entire message, including time slot #1 through #16, is referred to as a Frame of data throughout this document.

**NOTE:** The first pulse pair in a frame is in time slot #2 and is hence referred to as pulse pair #2. As stated above, the eight even pulse pairs #2, 4, 6, 8, 10, 12, 14, & 16 carry temperature data. #2 through #10 correspond to the lowest to the highest temperature sensors in the probe rod, respectively. #12 corresponds to the temperature sensor in the head electronics. #14 and #16 are references. The five sensors are spaced apart equally in the probe rod. (See Chapter 5 for more information on computing the temperature).

<sup>1</sup> For probes over 18 feet in length, the frame duration should be doubled. This is due to the longer wire propagation time.

<sup>2</sup> Since the magnetostrictive wire velocity is about 9 microseconds per inch, a 110 MHz. clock would provide a single level readout resolution of 0.001". Since the 7100 probe utilizes the patented resolution-doubling reflection method, the resolution would be 0.0005". If a more practical 40 MHz. clock is used, the resolution is 0.001375".

Specifications	
Input Voltage	16 to 31 VDC
Sensor Length	Stainless Steel up to 24' PVDF up to 70'
Enclosure Rating	Material 316 SS or PVDF, IP 68
Typical Level Resolution (Controller Dependent)	0.010" Inventory Mode 0.001" Leak Detection Mode
Linearity	+/- 0.01% of Full Scale +/- 0.010", whichever is greater
Repeatability	+/- 0.001% of Full Scale +/- 0.00025", whichever is greater
Temperature Measurement	Up to 5 along the sensor span
Temperature Accuracy, Absolute	+/- 2°F
Typical Temperature Resolution (Controller Dependent)	+/- 0.01°F
Temperature Sensing Range	- 40°F to +158°F or -40°C to 70°C
Operating Temperature Range	- 40°F to +158°F or -40°C to 70°C
Sensor Output	Pulse Position Modulated
Distance to Monitor	Over 1000' using twisted pair wire
Floats (not included)	Specs based on 4" standard floats
Approvals	<p><b>NORTH AMERICA</b> CLASS I,II,III, DIVISION 1, GROUPS D,E,F,G; T4 (7100 K&amp;V) GROUPS C,D,E,F,G; T4 (7100 M&amp;R) Exia SECURITE INTRINSEQUE</p> <p><b>EUROPEAN UNION IEC</b> CE 0575   II 1 G            Ex ia IIA T4 Ga (7100 K&amp;V)            Ex ia IIB T4 Ga (7100 M&amp;R)            IECEx UL 11.0041X            DEMKO 09 ATEX 0902049X            LISTED            14X7   </p>
Specifications are subject to change without notice. Patented.	

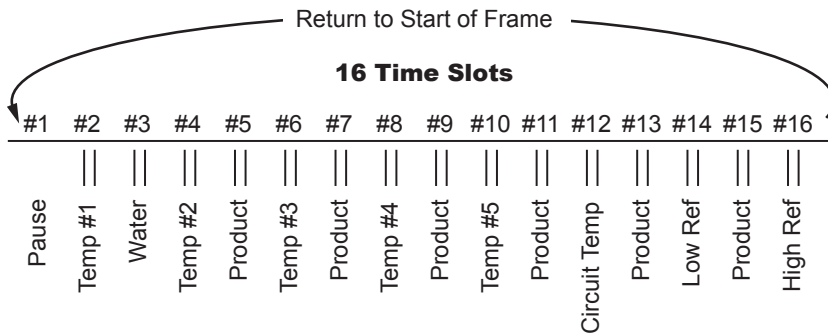

**Figure 1: One frame of Data**

## 1.2: Frame Protocol

All 7100 probes transmit data in the same general format. In this format, information is conveyed during a discrete period of time called a frame. The duration of a frame varies depending on the probe type. Table 1 specifies the frame periods for various probe types.

7100 series probe data consists of a series of pulses that are transmitted along the wire pair that provides power to the probe. Pulses are grouped in pairs called readings. Position and temperature information can be determined by measuring the period between the two pulses that comprise a reading.

A frame consists of a sync. period followed by 15 readings. The sync. period is a period of time during which no pulses occur. An external device that is attempting to synchronize with the probe data should start looking for the first pulse in reading 1 after detecting a period greater than sync. period during which no pulses occur. Table 1 lists the recommended sync period for various probe types.

Table 1 - 7100 Probe parameters by probe type				
Probe Type	Overall Length	Frame Period	Sync Period	Reference Magnet
Types 1, 4	$0 < L \leq 18$	72 ms	7 ms	No
Types 2, 5	$18 < L \leq 24$	144 ms	16.6 ms	No
Types 3, 6	$24 < L$	144 ms	16.6 ms	Yes

**NOTE:** Probe types 1, 2, and 3 are 5 thermistor probes (R5 designation in part number). Probe types 4, 5, and 6 are 1 thermistor probes (R1 designation in part number).

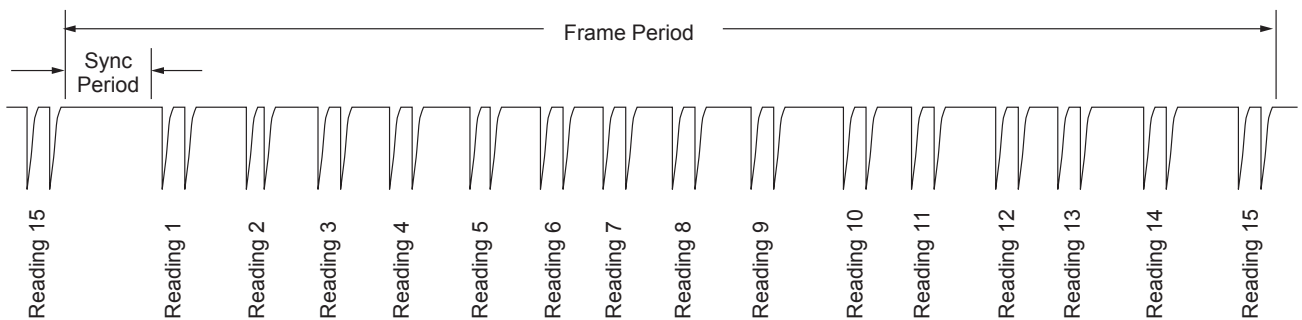

**Figure 2: Data Frame Relationship Between the Data Pulses, Sync and Frame Periods**

The type of information contained in each reading varies depending on the probe type. Table 2 specifies the data pattern for various probe types.

<b>Table 2 - Reading Data Type Specification by Probe Type</b>		
	<b>Types 1, 2, 3</b>	<b>Types 4, 5, 6</b>
<b>Reading 1</b>	Temp 1	Temp 1
<b>Reading 2</b>	Product or Water*	Product or Water*
<b>Reading 3</b>	Low Ref Temp	Temp 2
<b>Reading 4</b>	Product	Product
<b>Reading 5</b>	High Ref Temp	Temp 3
<b>Reading 6</b>	Product	Product
<b>Reading 7</b>	Low Ref Temp	Temp 4
<b>Reading 8</b>	Product	Product
<b>Reading 9</b>	High Ref Temp	Temp 5
<b>Reading 10</b>	Product	Product
<b>Reading 11</b>	Circuit Temp	Circuit Temp
<b>Reading 12</b>	Product	Product
<b>Reading 13</b>	Low Ref Temp	Low Ref Temp
<b>Reading 14</b>	Product	Product
<b>Reading 15</b>	High Ref Temp	High Ref Temp
* For single float probes, this frame contains product data. For dual float probes, this frame contains water data.		

When calculating Water or Product positions, one must consider whether or not the probe uses a reference magnet. For probes that use a reference magnet (type 3 and type 6), position can be calculated using the following formula:

$$\text{Position} = \text{Measured Period} / \text{Wire Speed}$$

Where:

Measured Period = the time between pulses in a reading ( $\mu\text{s}$ )

Wire Speed = ( $\mu\text{s} / \text{inch}$ )

Position = distance from internal reference

For probes that do not use a reference magnet (types 1, 2, 4, and 5), position can be calculated using the following formula:

$$\text{Position} = \text{Measured Period} / \text{Wire Speed} * 2$$

# 1.3: Installation and Dimension Drawings

## 7100 Flex Stik Installation Drawing

**\*\*APPROVED DOCUMENT\*\***  
CHANGES TO THIS DOCUMENT  
REQUIRE AGENCY APPROVAL

REVISION			
REV.	DESCRIPTION	DATE	BY
H	CE0575 WAS CE0344, ADDED NOTES 6, 7, 8	10/11/13	MJD

NON HAZARDOUS AREA

HAZARDOUS AREA

NORTH AMERICA  
CLASS I,II,III, DIVISION 1,  
GROUPS D,E,F,G; T4 (7100 K&V)  
GROUPS C,D,E,F,G; T4 (7100 M&R)  
Exia SECURITE INTRINSEQUE

EUROPEAN UNION IEC  
**CE0575**  
Ex ia IIB T4 Ga (7100 K&V)  
Ex ia IIB T4 Ga (7100 M&R)  
IECEX UL 11.0041X  
DEMKO 09 ATEX 0902049X

**NOTES: UNLESS OTHERWISE SPECIFIED**

1. MINIMUM VOLTAGE TO OPERATE THE PROBE IS 16V.
2. THE SELECTED BARRIER SHALL BE APPROVED WITH INTRINSICALLY SAFE CIRCUITS FOR THE HAZARDOUS LOCATION CLASS AND GROUP AS APPROPRIATE FOR THE APPLICATION.
3. ELECTRONIC EQUIPMENT CONNECTED TO THE ASSOCIATED APPARATUS MUST NOT USE OR GENERATE MORE THAN 250vrms, WITH RESPECT TO EARTH GROUND.
4. INSTALLATIONS SHALL COMPLY WITH THE LATEST EDITION OF THE NATIONAL ELECTRICAL CODE (ANSI/NFPA 70) AND THE CANADIAN ELECTRICAL CODE (CEC) AND IEC 60079-14, EN 60079-14 OR OTHER APPLICABLE STANDARDS.
5. ALL CABLES MUST BE 24 GAUGE OR HEAVIER.
6. INSTALLATIONS SHALL BE IN ACCORDANCE WITH ANSI/ASI RP 12.06.01, INSTALLATION OF INTRINSICALLY SAFE SYSTEMS FOR HAZARDOUS (CLASSIFIED) LOCATIONS.
7. FOR FM APPROVAL, THE ASSOCIATED APPARATUS MUST BE FM APPROVED.
8. IN ACCORDANCE WITH ATEX SPECIAL CONDITIONS FOR USE, THE FOLLOWING SHOULD BE CONSIDERED; THE SURFACE OF THE ISOLATING MATERIAL (PVDF) EXCEEDS THE LIMIT OF 4CM AS SPECIFIED IN EN60079-26, AND THE PROBABILITY OF ELECTROSTATIC CHARGING NEEDS TO BE CONSIDERED FOR USE IN CATEGORY 1 (ZONE 0). CLEAN ONLY WITH A DAMP CLOTH.

TERMINATE BARRIER EARTH GROUND TO THE GROUND BUS OF THE POWER DISTRIBUTION PANEL. RESISTANCE TO GROUND MUST NOT BE GREATER THAN 1 OHM.

SELECTED BARRIERS SHALL HAVE ENTITY PARAMETERS SUCH THAT:

$V_{max} \geq V_{oc}$   
 $I_{max} \geq I_{sc}$   
 $C_i + C_{wire} \leq C_a$   
 $L_i + L_{wire} \leq L_a$

SELECTED BARRIER MUST BE INSTALLED IN ACCORDANCE WITH MANUFACTURER'S INSTALLATION INSTRUCTIONS.

APPLICABLE STANDARDS

IEC 60079-0 6th Edition  
IEC 60079-11 6th Edition  
IEC 60079-26 2nd Edition  
EN 60079-0:2012  
EN 60079-11:2012  
EN 60079-26:2007

TRANSUDER ENTITY PARAMETERS					
WIRE NAME	Pi	Vmax	Imax	Ci	Li
POWER TO COMMON	1W	31V	165mA	OpF	OuH

AMBIENT TEMPERATURE RANGE:  
 $-40^{\circ}C \leq T_{amb} \leq +70^{\circ}C$

**\*\*\* WARNING \*\*\***  
TO PREVENT IGNITION, DISCONNECT POWER BEFORE SERVICING

IF WIRE PARAMETERS ARE UNKNOWN THEN THE FOLLOWING SHALL BE USED:

$60pF/ft. = C_{wire}$   
 $.2uH/ft. = L_{wire}$

FOR EXAMPLE: 1000 ft X 60 pF/ft. = 0.06uF

THIRD ANGLE PROJECTION

SURFACE FINISH  $\frac{63}{\sqrt{16}}$   
UNLESS OTHERWISE SPECIFIED

TOLERANCE ALLOWANCE  
UNLESS OTHERWISE SPECIFIED:

+/- 0.010 ON 2 PLACE DECIMALS  
+/- 0.005 ON 3 PLACE DECIMALS  
+/- 0.0005 ON 4 PLACE DECIMALS  
+/- 30 MIN. ON ALL ANGLES

COPYRIGHT © 2013. AMETEK AUTOMATION & PROCESS TECHNOLOGIES. ALL RIGHTS RESERVED. DRAWING IS PROPERTY OF AMETEK AUTOMATION & PROCESS TECHNOLOGIES. UNAUTHORIZED USE, DUPLICATION OR DISTRIBUTION IS STRICTLY PROHIBITED BY FEDERAL LAW.

**AMETEK**  
AUTOMATION & PROCESS TECHNOLOGIES

Clawson, MI 48017 U.S.A.

DR. *X.W.*

DATE 2/26/98

APP. G.S.L.

DATE 10/11/13

SCALE NONE

TITLE

INSTALLATION DRAWING  
PETRO/FLEX STIK  
SERIES TANK PROBES

DRAWING NO.	REV.	SIZE
E0234300	H	A

# 7100 Dimension Drawing, Page 1

REV.	DESCRIPTION	REVISION	DATE	BY
H	ADDED "P" TO TANK MOUNTING METHOD IN PART NUMBER		2/1/08	MJD
J	ADDED NOTE FOR THERMISTOR LOCATION FOR V STYLE PROBES (ECR 1552)		6/6/08	KTP
K	UPDATED CHARTS FOR V & VB PROBES		1/6/09	KTP
L	ADDED R1 & T1 OPTIONS FOR VB		11/5/09	MJD

**SAMPLE PART NUMBER**

7100 - M - 048 - R5 - X - E2 - L058

XXX = O.A.L. (in)  
AFFECTS TOP DIMENSION (#)  
O.A.L. BASED ON ACTIVE SENSING SPAN. MIN. O.A.L. = SPAN+10" (M, R & K-C STYLE);  
SEE DRAWING (V & VB)

F1 = ONE FLOAT  
F2 = TWO FLOATS

TANK MOUNTING METHOD:  
C = COMPRESSION FITTING / 0-40° TEMPERATURE RANGE ONLY  
B = COMPRESSION FITTING / 0-40° TEMPERATURE RANGE ONLY  
X = STANDARD REPLACEMENT PROBE FOR FIXED BOTTOM ONLY  
R(0-5) = NUMBER OF THERMISTORS  
T1 = ONE THERMISTOR (FIXED LOCATION)  
048 = TEMPERATURE SPAN (in)

M = ST. STEEL TUBE W/MINI CONNECTOR, CATHODIC PROTECTIVE BOOT & FOOT (BOOT & FOOT NOT SHOWN)  
S1 = ST. STEEL TUBE W/RIGHT ANGLE NPT CONNECTOR  
K = FLEXIBLE PVDF TUBE W/MALE NPT PVDF CONNECTOR, & OPERATING TEMPERATURE RANGE 0-40 °C (32-104°F)  
V = FLEXIBLE PVDF TUBE W/MALE NPT PVDF CONNECTOR & 2 FT. POTTED TEFLON CABLE

**R-STYLE**

**M-STYLE**

**7100K-OPTION G-STYLE**

**V-STYLE**

**STANDARD PROBE LENGTHS:**

PROBE TYPE	MAXIMUM O.A.L. (in)	MINIMUM O.A.L. (in)
7100R (R5)	288	36
7100R (R1)	288	31
7100R (T1)	288	17
7100M (R5)	288	36
7100M (R1)	288	31
7100M (T1)	288	17
7100V (R5)	840	51
7100V (R1&T1)	840	44
7100K-C (R5)	192	64
7100K-C (R1&T1)	192	22

**THERMISTOR SPACING:**

PROBE TYPE	OVERALL PROBE LENGTH	THERMISTOR SPACING @ 24°C
7100 M & R (R5)	ALL STD. LENGTHS	18"
7100 M & R (R1)	L = 144"	4"
7100 V (R1 & T1)	L = 144"	27"
7100 V (R1 & T1)	145" ± L = 288"	30"
7100 V (R1 & T1)	289" ± L = 432"	35"
7100 V (R1 & T1)	433" ± L = 600"	39"
7100 V (R1 & T1)	601" ± L = 720"	42"
7100 V (R1 & T1)	721" ± L = 840"	45"
7100 K-C (R5)	L = 192"	5 1/2"

**NOTES:** UNLESS OTHERWISE SPECIFIED

- OPERATING TEMPERATURE OF K-C STYLE PROBE IS 0-40°C (32-104°F)
- ALL DIMENSIONS ARE FOR REFERENCE ONLY.
- THERMISTORS ARE SPACED EQUALLY OVER RANGE SPECIFIED.
- THERMISTORS ARE SPACED EQUALLY OVER TEMPERATURE SPAN + DEAD BAND + TANK BOTTOM CLEARANCE

**THIRD ANGLE PROJECTION**

SURFACE FINISH:  $\sqrt{16}$

UNLESS OTHERWISE SPECIFIED TOLERANCE ALLOWANCE:  $\pm 0.010$  ON 2 PLACE DECIMALS,  $\pm 0.0005$  ON 4 PLACE DECIMALS,  $\pm 0.0005$  ON ALL ANGLES

**EXPANSION CLEARANCE REQ'D AT BOTTOM OF TANK (V STYLE):**  
MIN. CLEARANCE = (O.A.L.) X (MAX. OPERATING TEMP(°C) - 20) X (.00014)  
OVERALL LENGTH = TANK HEIGHT - CLEARANCE + 1"

**TANK BOTTOM CLEARANCE**

O.A.L. (in)	DEAD BAND (in)	TANK BOTTOM CLEARANCE (in)
51-144	6.00	1.00
145-288	8.00	2.00
289-432	12.00	3.00
433-600	15.00	4.00
601-720	17.00	5.00
721-840	19.00	6.00

**REVISION**

REV.	DESCRIPTION	DATE	BY
H	ADDED "P" TO TANK MOUNTING METHOD IN PART NUMBER	2/1/08	MJD
J	ADDED NOTE FOR THERMISTOR LOCATION FOR V STYLE PROBES (ECR 1552)	6/6/08	KTP
K	UPDATED CHARTS FOR V & VB PROBES	1/6/09	KTP
L	ADDED R1 & T1 OPTIONS FOR VB	11/5/09	MJD

**TITLE**

DIMENSION DRAWING  
7100 SERIES STIK  
TANK PROBES (2 SHEETS)

DR: K.P.  
DATE: 09/28/01  
APP:

SCALE: NONE

DRAWING NO: D0247300

REV. SIZE: L B



# 7100 Dimension Drawing, Page 2

REV.	DESCRIPTION	REVISION	DATE	BY
F	UPDATED PART NUMBERS DESCRIPTION, SPAN IN 7100R & DAL FOR 7100K-C		4/19/05	KTP
G	REVISED MAX OAL OF "VB" STYLE PROBE TO 608"		8/24/06	KTP
H	ADDED "P" TO TANK MOUNTING METHOD IN PART NUMBER		2/1/08	IMD
J	ADDED NOTE FOR THERMISTOR LOCATION FOR V STYLE PROBES (LEGR 195Z)		6/6/08	KTP
K	UPDATED CHARTS FOR V & VB PROBES		1/6/09	KTP
L	ADDED R1 & T1 OPTIONS FOR VB		11/5/09	IMD

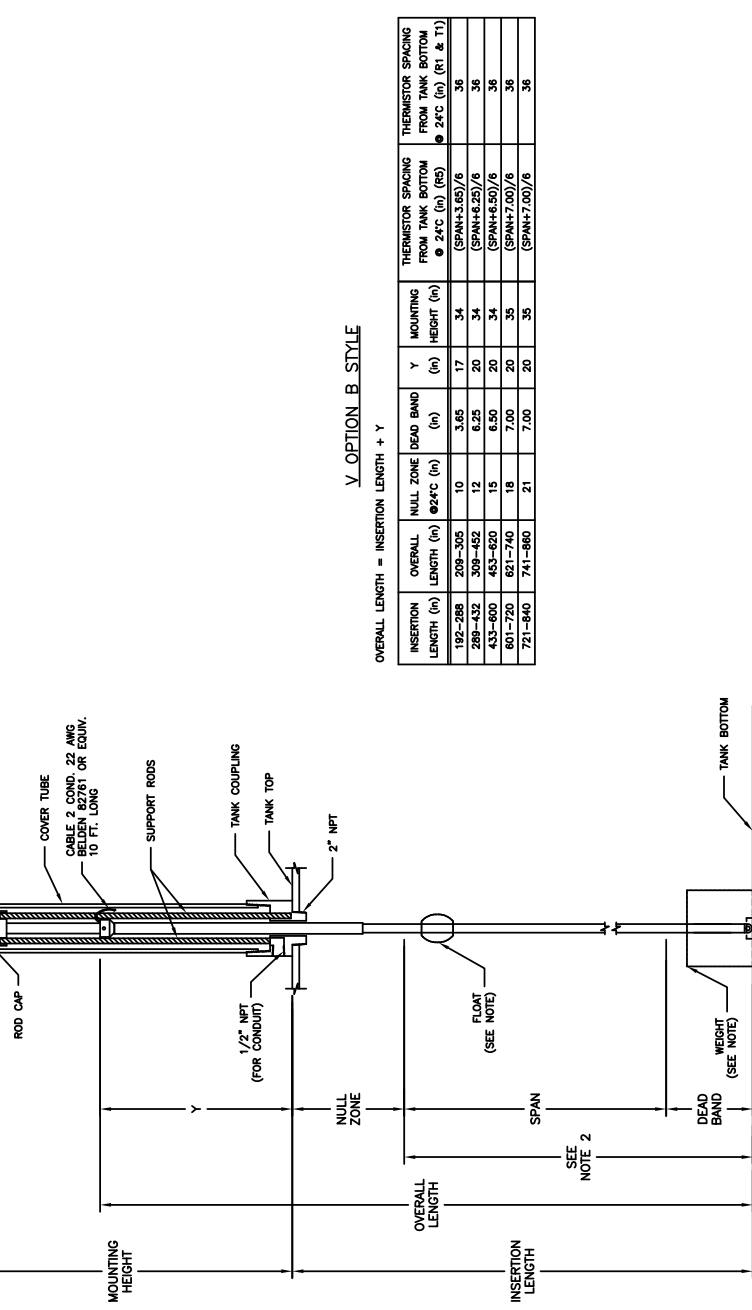

Y OPTION B STYLE

OVERALL LENGTH = INSERTION LENGTH + Y

INSERTION LENGTH (in)	NULL ZONE Ø24°C (in)	DEAD BAND (in)	Y MOUNTING HEIGHT (in)	THERMISTOR SPACING FROM TANK BOTTOM @ 24°C (in) (R1 & T1)	THERMISTOR SPACING FROM TANK BOTTOM @ 24°C (in) (R1 & T1)
192-288	10	3.65	17	34	35
289-432	12	6.25	20	34	35
433-600	15	6.50	20	34	35
601-720	18	7.00	20	35	35
721-840	21	7.00	20	35	35

- NOTES: 1. FLOAT AND WEIGHT TYPE & GEOMETRY ARE DEPENDANT ON APPLICATION.
- 2. TEMPERATURE SENSORS ARE SPACED EQUALLY OVER RANGE SPECIFIED.

SHEET 2 OF 2

THIRD ANGLE PROJECTION	DR. K.P.	TITLE
SURFACE FINISH UNLESS OTHERWISE SPECIFIED	DATE 09/28/01	DIMENSION DRAWING
TOLERANCE ALLOWANCE UNLESS OTHERWISE SPECIFIED: +/- 0.005 ON 3 PLACE DECIMALS +/- 0.0005 ON 4 PLACE DECIMALS +/- .30 MIN. ON ALL ANGLES	SCALE NONE	7100 SERIES STIK
UNLESS OTHERWISE SPECIFIED	DRAWING NO. D0247300	TANK PROBES (2 SHEETS)
AMETEK AUTOMATION & PROCESS TECHNOLOGIES Clawson, MI 48017 U.S.A.	DATE	REV. SIZE
		L B

## Chapter 2: Interfacing to Probe

The pulse signals coming from the probe are superimposed onto the nominal 24 VDC power supply connections. As shown in Figure 3, the pulses are negative-going and are large in amplitude, nominally 20 volts peak. The peak is negative going and only a few microseconds in duration. The leading edge is the proper edge to use for timing purposes. The large signal amplitude offers high noise immunity.

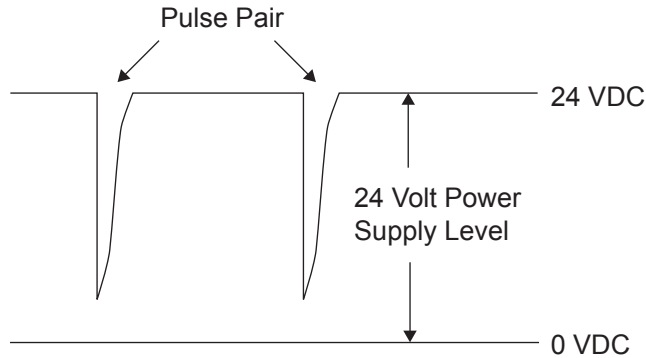

**Figure 3: Pulse Signals**

A simple approach to getting 5 volt logic levels from the input signal is to simply set a comparator level as shown in Figure 6. The comparator output can then be used to create a gate signal for a counter circuit. The circuit example in Section 2.1 (page 10) has a variation of this concept using a 5:1 pulse transformer to eliminate the reference to 24 VDC and make the comparison relative to circuit common (with inverted polarity).

Probe power supply impedance will have an effect on pulse amplitude. Wire lengths will vary the pulse amplitude. Wire has an associated inductance, resistance and capacitance which will change the amplitude of the coupled pulse. Users may wish to load their circuit to minimize wire effects.

The chart below gives relative times by which a user can distinguish timing for various probe lengths.

Length	Float Position	Tstart	Tstop	$\Delta t = \text{Position}$
12"	1"	160 $\mu\text{sec}$	180 $\mu\text{sec}$	20 $\mu\text{sec}$
12"	12"	50 $\mu\text{sec}$	290 $\mu\text{sec}$	240 $\mu\text{sec}$
30"	1"	340 $\mu\text{sec}$	360 $\mu\text{sec}$	20 $\mu\text{sec}$
30"	30"	50 $\mu\text{sec}$	650 $\mu\text{sec}$	600 $\mu\text{sec}$
100"	1"	1040 $\mu\text{sec}$	1060 $\mu\text{sec}$	20 $\mu\text{sec}$
100"	100"	50 $\mu\text{sec}$	2050 $\mu\text{sec}$	2000 $\mu\text{sec}$
200"	1"	2040 $\mu\text{sec}$	2060 $\mu\text{sec}$	20 $\mu\text{sec}$
200"	200"	50 $\mu\text{sec}$	4050 $\mu\text{sec}$	4000 $\mu\text{sec}$

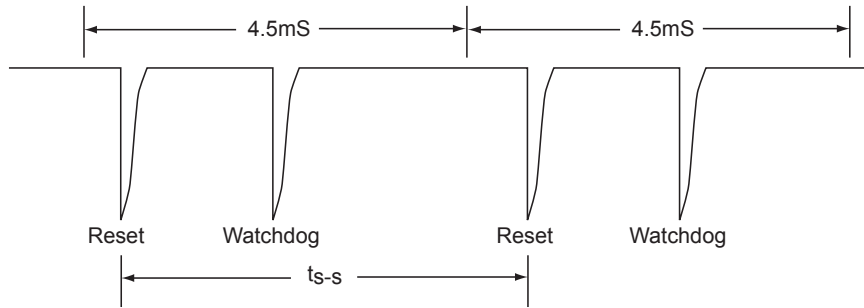

**Figure 4: Start Pulse**

**NOTE 1:**  $t_{S-S}$  = time from 1st start pulse in one frame to next start pulse in the next frame.

**NOTE 2:** Start pulse can start anywhere in the 4.5 ms frame. The stop pulse will follow at the correct time. The  $t_{S-S}$  is not consistent. The user does not have the 4.5 ms frame as a reference. The user must use the watchdog timeout during the pause frame to “sync up”. The watchdog timer should be reset on both the start and stop pulse.

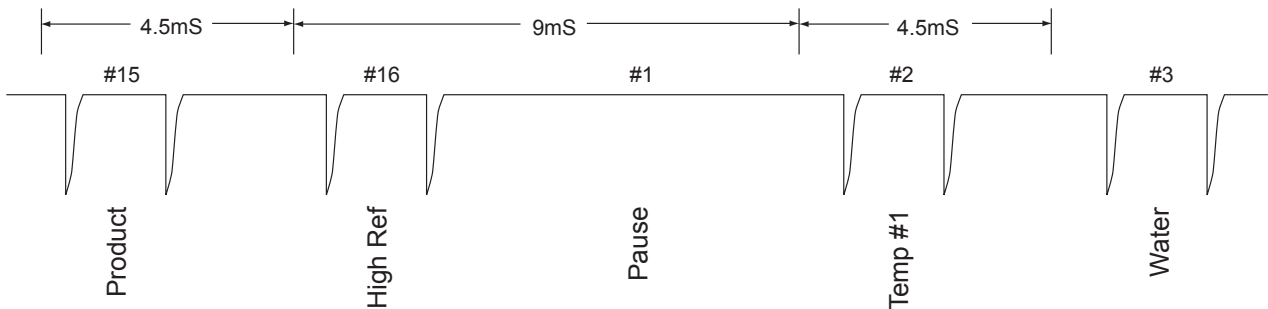

**Figure 5: Pause Period Timing**

**NOTE:** Although the timebase is generated with a crystal oscillator, the times shown are NOT exact times. Also, the initial pulse within a window of the frame does not start at the beginning of the window. See Section 3.1: Synchronizing with a Watchdog Timer and footnote 3 for more information.

## 2.1: Interface Hardware

A typical console has the following sub-systems:

1. Probe Multitplexer
2. Intrinsic Safety Barrier
3. Pulse Discriminator
4. Gate Circuit
5. High Speed Counter

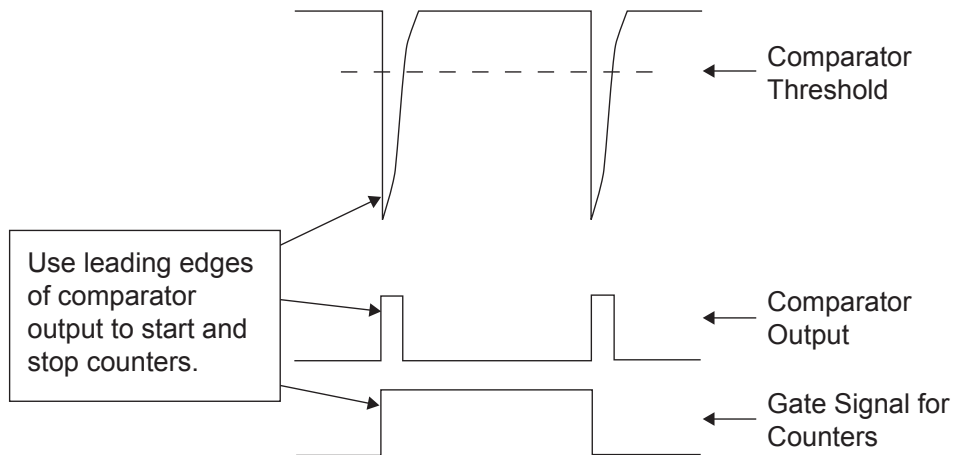

**Figure 6: Start and Stop Counters**

Figure 7 shows typical means of achieving each of these sub-systems. The multiplexing is achieved with the use of a PNP-style bipolar driver IC, where only one output is turned on at a given time. The output that is turned on serves two functions; it couples power to the corresponding probe, and it conducts the probes output pulses back to the pulse discriminator.

The intrinsic safety barrier is achieved where the dotted line is shown.

A Stahl Intrinsicpak 9001/01-280-110-101 could be used as an "off-the-shelf" barrier when installed in accordance per Stahl manual 9001/60/301 and local safety standards. Safety barrier entity parameters must meet the requirements as called out in installation drawing E0234300.

The pulse discriminator is comprised of a 5:1 pulse transformer that is capacitively coupled to the intrinsically safe power supply (where the probe pulses are found) and used to invert the pulses, amplify them, and remove the 24 VDC. offset. Finally, a comparator is used to generate the final output used to drive the gate circuit. The comparison is done with a nominal threshold voltage of approximately 1 VDC.

The gate and counter circuits are shown only in block diagram form. The clock feeding the counters should be selected to yield the resolution required (see footnote 2, page 2). The gate circuit should enable the counters upon the first pulse in a pulse pair and disable the counters on the second after which the counter values are taken. The gate signal is also used to alert the resident computer that it is time to take the data.

For clock frequencies above 35Mhz., it is recommended that all analog comparators and digital gating circuit components be relatively high speed. (If FAST or ACT logic is used for the counters, then also use it for the gating circuits.)

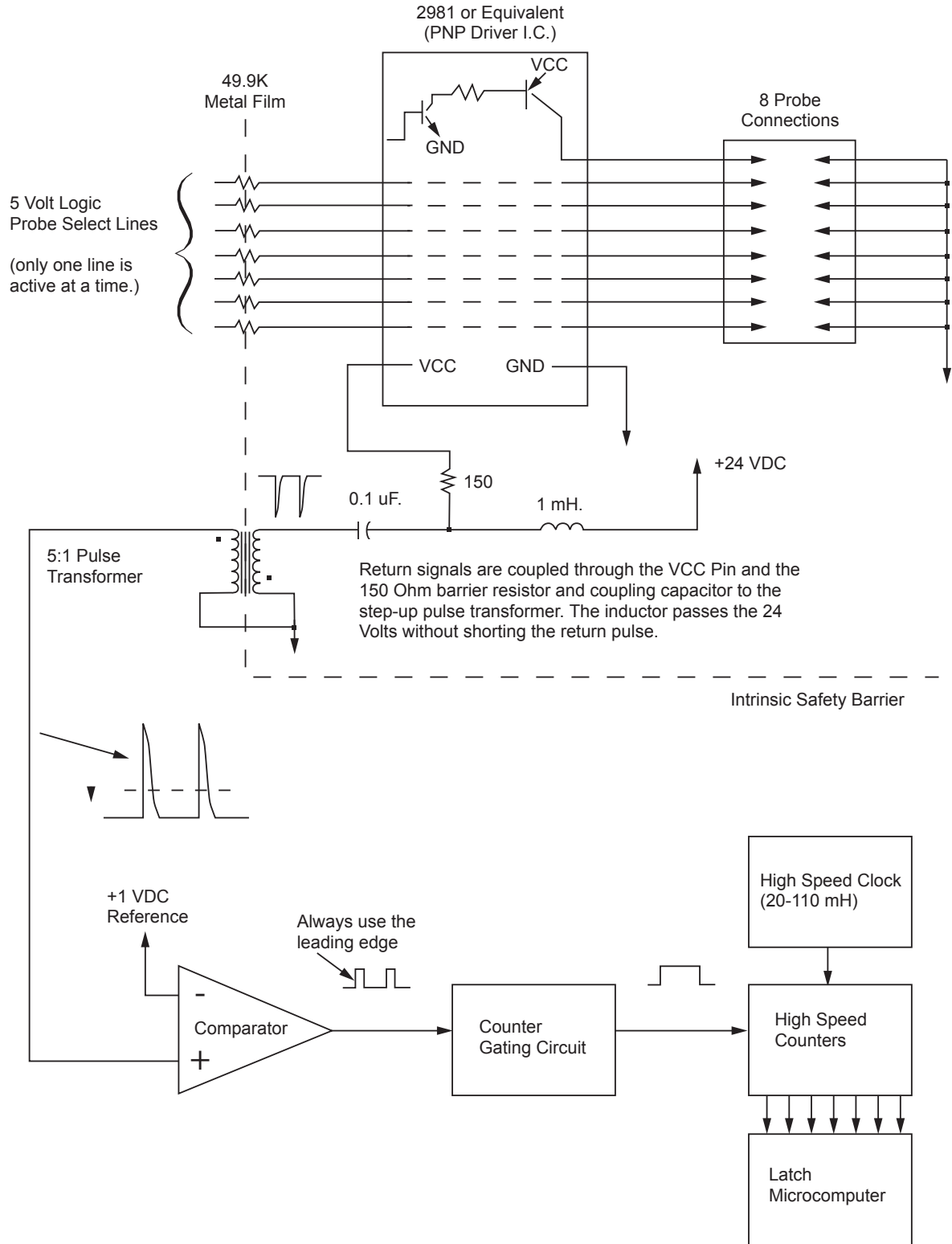

**Figure 7: Typical Console Circuitry**

# Chapter 3: Getting the Data

The method that data is communicated between the probe and the console is described in Section 1.1: Data Protocol. The user should understand the data protocol scheme before attempting to process the data.

## 3.1: Synchronizing with a Watchdog Timer

Referring to Figures 1 and 5, note that there is only one pause period per frame and therefore, only one time during the sequence when no pulses will be received for approximately 9 milliseconds. A hardware or software watchdog timer may be implemented to time-out after 7 milliseconds (for probes > 18', this time should be 14 milliseconds) which will occur only during frame #1, the pause frame. The next 15 pulse pairs may then be recorded in the sequence shown in Figure 1.

**NOTE:** The times depicted in Figure 5 are not exact times<sup>3</sup>. A watchdog timer setting of 7 milliseconds should generally be used.

## 3.2: System Hardware Setup

Before discussing signal processing, a brief review of the console hardware is in order. Refer to Section 2 as required.

Based on a 16 foot maximum probe length, the number of bits required for the probe counter circuit is the duration of the low reference temperature pulse pair. With a 3 ms low reference pulse duration and a 100 MHz clock frequency, the number of bits can be calculated. Dividing the low reference pulse pair duration by the period of the clock yields 300,000 counts. Converting this number to hexadecimal will show the number of required bits. In this case, 19.

<sup>3</sup> Although the time between adjacent frames is generated with an internal crystal oscillator, the actual pulse pair for a temperature frame is delayed a few hundred microseconds nominally. This is independent of any temperature data. The product and water float pulse pairs may be delayed as much as 2 milliseconds. This delay is affected by the corresponding float position. The longest delay is experienced with a long probe with the float near the bottom.

### 3.3: System Software Setup

Although one frame of data is sufficient to obtain valid product, water, and temperature readings, averaging multiple frames is generally much more appropriate. This is because all elements in the system are subject to slight uncertainties and/or the effects of electrical noise or mechanical vibration. This includes the magnetostrictive wire in the probe, the probe electronics, the transmission wire between the probe and the console, and the console electronics.

The number of frames of data required for a good probe reading is application dependent. Since the number of frames of data taken is directly proportional to the console update time, the user should review the system criterion before implementing a design. For the sake of discussion, 16 frames of data will be taken. The following table shows the particulars of a console taking in 16 frames of data.

Parameter	Result	Notes
Frames Read	16	16 Frames as defined
Pulse Pairs Read	240	16 Frames x 15 Pulse Pairs/Frame
Product Pulse Pairs	96	16 Frames x 6 Pulse Pairs/Frame
Water Pulse Pairs	16	16 Frames x 1 Pulse Pairs/Frame
Temp. Pulse Pairs	128	16 Frames x 8 Pulse Pairs/Frame
Pause Pulse Pairs	0	NO PULSE DURING PAUSE
Console Update Time	1.17 Seconds	See Below
Required Memory	720 Bytes	See Below

The update time is calculated as:

$$t_{\text{update}} = 16 \text{ Frames} \times \left\{ \frac{16 \text{ Time Slots}}{1 \text{ Frame}} \right\} \times \left\{ \frac{4.57 \text{ Milliseconds}}{1 \text{ Time Slot}} \right\} = 1170 \text{ Ms.}$$

**NOTE:** This update time does not include the time required to become synchronized. Up to one additional frame is necessary to synchronize making the total 1.24 seconds.

The required memory is calculated as:

$$\text{Memory Bytes} = 16 \text{ Frames} \times \left\{ \frac{15 \text{ Pulse Pairs}}{1 \text{ Frame}} \right\} \times \left\{ \frac{3 \text{ Bytes}}{1 \text{ Pulse Pair}} \right\} = 720 \text{ Bytes}$$

The user will want to configure the system based on individual requirements for update time and memory space. Readings are more precise when more frames are read but more time and memory are required.

# Chapter 4: Processing the Data

Data acquisition was discussed in Section 3 to the degree that memory locations are filled with an array of data from a selected number of frames. It is now appropriate to test for data integrity, average and/or filter the data, and then convert from binary counter values to scaled, meaningful numbers.

## 4.1: Front End Algorithm

A technique for eliminating any possible erroneous data is to discard some of the highest and lowest count values. Lets assume that there is some uncontrolled source of harsh electrical noise causing erroneous data to be received once approximately every 100 to 1000 frames. The table below shows appropriate numbers of High and Low discard values to ensure that no erroneous data is used.

<b>Parameter</b>	<b>Highs Discarded</b>	<b>Lows Discarded</b>	<b>Probe Reading is the Average of</b>
Product	12	12	72 of 96
Water	2	2	12 of 16
Temp #1	2	2	12 of 16
Temp #2	2	2	12 of 16
Temp #3	2	2	12 of 16
Temp #4	2	2	12 of 16
Temp #5	2	2	12 of 16
Circuit Temp	2	2	12 of 16
LO Reference Temp.	2	2	12 of 16
HI Reference Temp.	2	2	12 of 16

After discarding the Highs and Lows, the remaining data is averaged and the results are referred to as one Probe Reading. These discard numbers are only guidelines. They may be changed to accommodate more or less frequently encountered noise problems, depending upon the installation environment.

One probe reading contains ten values, one for product level, one for water level, and eight for temperature.



# Chapter 5: Computing the Temperature

A probe reading contains 15 values for product, water and temperature. The product and water values are each useful by themselves (a single product or water value may be converted with linear math to represent the float position).

Unlike the product and water values, the temperature values are always accompanied by two reference values. A single temperature sensor value is of no use without its associated reference temperature values. The use of reference values eliminates the effects of circuit drift and produces exceptionally good repeatability.

The 7100 Liquid Level Probe uses thermistors as the temperature sensing elements. All thermistors exhibit known, well defined non-linearity. In our application, the non-linearity of the temperature data is in the range of a few percent. (See Section 5.1: Improving Measurement Accuracy)

As shown in Section 5.1: Improving Measurement Accuracy, the first step in computing the temperature of a given sensor is to use a linear equation to interpolate between the reference temperatures. The above mentioned non-linearity will then be present in the result.

## 5.1: Improving Measurement Accuracy

The temperature measurement circuitry of the 7100 probe generates temperature pulse pairs with the time interval directly proportional to the resistance of a parallel connected thermistor (or reference temperature resistor) and a fixed 37.4 K resistor. The 37.4 K parallel resistor serves to keep the time range of the temperature pulses within reasonable limits over the probe's temperature range.

Variations in parameters of thermistors, time defining capacitors, and other parts of the probe introduce additional error to the temperature measurement. To reduce this error the 7100 probe transmits signals for two reference temperatures: +5 °C (low reference), and +50 °C (high reference). The following sequence of calculations compensates for errors using the reference signals, and takes into account the thermistor plus 37.4 K resistor non-linearity.

**Step 1** - Get reliable time counts for each temperature read, including the temperature references.

Example:

- 1) Take 16 reads of a temperature.
- 2) Discard 2 highest and 2 lowest readings.
- 3) Take average value of the 12 remaining readings.

**Step 2** - Calculate linear approximation of temperature ( $T_{LIN}$ ) using the following formula:

$$T_{LIN} = [(R - L) * (H_{REF} - L_{REF}) / (H - L)] + L_{REF}$$

Where:

- R = counts for thermistor,
- L = counts for low reference,
- H = counts for high reference,
- $L_{REF}$  = low reference = 5 °C,
- $H_{REF}$  = high reference = 50 °C.

$T_{LIN}$  is a normalized value for temperature that compensates for errors caused by variations of the probe parts' parameters. This is not actual temperature yet. It does not take into account non-linearity of the thermistor-parallel resistor combination.

**Step 3** - Using the attached table, find the linear temperature interval ( $T_{LIN1}$ ,  $T_{LIN2}$ ) and then the actual temperature interval ( $T_1$ ,  $T_2$ ) for  $T_{LIN}$ .

Example.

$$\begin{aligned}T_{LIN} &= 15.763 \text{ }^\circ\text{C}, \\T_{LIN1} &= 15.178 \text{ }^\circ\text{C}, \\T_{LIN2} &= 16.321 \text{ }^\circ\text{C}, \\T_1 &= 14 \text{ }^\circ\text{C}, \\T_2 &= 15 \text{ }^\circ\text{C}.\end{aligned}$$

**Step 4** - Calculate accurate table interpolated temperature  $T$ , using linear interpolation within intervals ( $T_{LIN1}$ ,  $T_{LIN2}$ ) and ( $T_1$ ,  $T_2$ ).

$$T = ((T_{LIN2} - T_{LIN1}) * T_2 - (T_{LIN2} - T_{LIN}) * (T_2 - T_1)) / (T_{LIN2} - T_{LIN1})$$

Example:

$$\begin{aligned}T_{LIN} &= 15.763 \text{ }^\circ\text{C}, \\T_{LIN1} &= 15.178 \text{ }^\circ\text{C}, \\T_{LIN2} &= 16.321 \text{ }^\circ\text{C}, \\T_1 &= 14 \text{ }^\circ\text{C}, \\T_2 &= 15 \text{ }^\circ\text{C}, \\T &= 14.512 \text{ }^\circ\text{C}\end{aligned}$$

<b>Temperature Calculation Table</b>									
<b>Actual Temp °C</b>	<b>Linear Temp °C</b>	<b>Actual Temp °C</b>	<b>Linear Temp °C</b>	<b>Actual Temp °C</b>	<b>Linear Temp °C</b>	<b>Actual Temp °C</b>	<b>Linear Temp °C</b>	<b>Actual Temp °C</b>	<b>Linear Temp °C</b>
-40	-25.141	0	-0.325	40	42.332	80	63.706	120	70.136
-39	-24.884	1	0.709	41	43.185	81	63.984	121	70.215
-38	-24.613	2	1.759	42	44.016	82	64.250	122	70.296
-37	-24.327	3	2.828	43	44.824	83	64.511	123	70.370
-36	-24.030	4	3.904	44	45.618	84	64.766	124	70.444
-35	-23.714	5	5.000	45	46.386	85	65.009	125	70.524
-34	-23.386	6	6.102	46	47.155	86	65.246	126	70.586
-33	-23.038	7	7.214	47	47.893	87	65.477	127	70.653
-32	-22.678	8	8.331	48	48.618	88	65.696	128	70.719
-31	-22.297	9	9.461	49	49.317	89	65.913	129	70.782
-30	-21.900	10	10.598	50	50.000	90	66.121	130	70.844
-29	-21.488	11	11.738	51	50.665	91	66.323	131	70.905
-28	-21.055	12	12.875	52	51.320	92	66.519	132	70.963
-27	-20.601	13	14.032	53	51.955	93	66.711	133	71.020
-26	-20.133	14	15.178	54	52.575	94	66.894	134	71.075
-25	-19.641	15	16.321	55	53.177	95	67.072	135	71.128
-24	-19.126	16	17.472	56	53.761	96	67.245	136	71.180
-23	-18.598	17	18.629	57	54.331	97	67.413	137	71.231
-22	-18.042	18	19.770	58	54.882	98	67.576	138	71.281
-21	-17.466	19	20.907	59	55.423	99	67.734	139	71.328
-20	-16.871	20	21.974	60	55.942	100	67.886	140	71.375
-19	-16.249	21	23.173	61	56.451	101	68.034	141	71.420
-18	-15.611	22	24.295	62	56.943	102	68.180	142	71.464
-17	-14.945	23	25.419	63	57.423	103	68.319	143	71.507
-16	-14.258	24	26.518	64	57.890	104	68.453	144	71.548
-15	-13.554	25	27.611	65	58.344	105	68.583	145	71.589
-14	-12.823	26	28.695	66	58.779	106	68.710	146	71.629
-13	-12.068	27	29.767	67	59.205	107	68.833	147	71.667
-12	-11.291	28	30.822	68	59.618	108	68.954	148	71.703
-11	-10.497	29	31.866	69	60.022	109	69.070	149	71.740
-10	-9.671	30	32.899	70	60.410	110	69.181	150	71.775
-9	-8.832	31	33.914	71	60.783	111	69.290		
-8	-7.968	32	34.920	72	61.153	112	69.396		
-7	-7.078	33	35.903	73	61.506	113	69.498		
-6	-6.178	34	36.868	74	61.849	114	69.597		
-5	-5.252	35	37.830	75	62.182	115	69.694		
-4	-4.297	36	38.759	76	62.510	116	69.789		
-3	-3.332	37	39.677	77	62.821	117	69.879		
-2	-2.347	38	40.582	78	63.127	118	69.968		
-1	-1.345	39	41.472	79	63.422	119	70.053		

**NOTE:** Consult the factory if calculations within a larger temperature range is required.



# EC Declaration of Conformity

**Manufacturer:** AMETEK Automation & Process Technologies  
6380 Brockway Road, Peck, MI 48466 USA

**Identification of Equipment:**  
7100 Stik Series Liquid Level Transducer

**Description of Device:**  
The device is a permanently mounted liquid level probe. It determines the level of a liquid based on signal reflections, caused by magnetic floats, in a wire running the length of the probe. These signals are amplified and processed, then relayed via a signal imposed on the input wires to the probe. The probe body and tube may be constructed of stainless steel or of a flexible PVDF polymer. These devices also take liquid level temperature measurements using thermistors located inside the probe tube.

**EC type certificate:** DEMKO (0539) 09ATEX0902049X  
Lyskaer 8, P.O. Box 514, 2730 Herlev, Denmark

**Conformity Specifications:** models 7100 M/R:  II 1 G Ex ia IIB T4 Ga Ta: -40°C to +70°C  
models 7100 K/V:  II 1 G Ex ia IIA T4 Ga Ta: -40°C to +70°C

Council Directives:

Directive 94/9/EC, ATEX
Directive 89/336/EEC, EMC

Harmonized Standards:

EN60079-0:2012	Electrical apparatus for explosive gas atmospheres - Part 0: General requirements
EN60079-11:2012	Electrical apparatus for explosive gas atmospheres - Part 11: Intrinsic safety "i"
EN60079-26:2007	Explosive atmospheres – Part 26: Construction, test and marking of group II category I G electrical apparatus
EN61010-1:2010	Safety Requirements for Electrical Equipment for Measurement, Control, and laboratory Use

Other Standards:

EN55011:1998	Limits and methods of measurement of radio characteristics of industrial, scientific and medical (ISM) Radio Frequency equipment, Class B, Group 1
EN50082-1:1992	Electromagnetic compatibility Generic immunity standard Part 1. Residential, commercial and light industry
IEC 801-2:1984	ESD Susceptibility
IEC 801-3:1984	Radiated Susceptibility, Electromagnetic Field
IEC 801-4:1988	Conducted Susceptibility, Burst Interference Transients

**Signed:** 

**Name:** Glenn S. Loding      **Dated:** 10/25/13  
**Position:** Engineering Manager      **Company:** AMETEK Automation & Process Technologies



## Other Products



LINEAR DISPLACEMENT TRANSDUCERS

PLC INTERFACE PRODUCTS

ROTARY POSITION PRODUCTS

PROGRAMMABLE LIMIT SWITCHES

EXTREME DUTY CABLE REEL PRODUCTS

ROTARY LIMIT SWITCHES

RESOLVERS

MILL DUTY ENCLOSURES

ULTRA HIGH SPEED PLS

SAFETY PRODUCTS

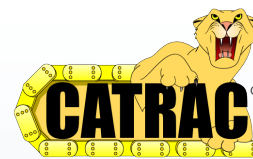

MADE IN AMERICA

© Copyright 2013. All Rights Reserved. Made in the USA.