

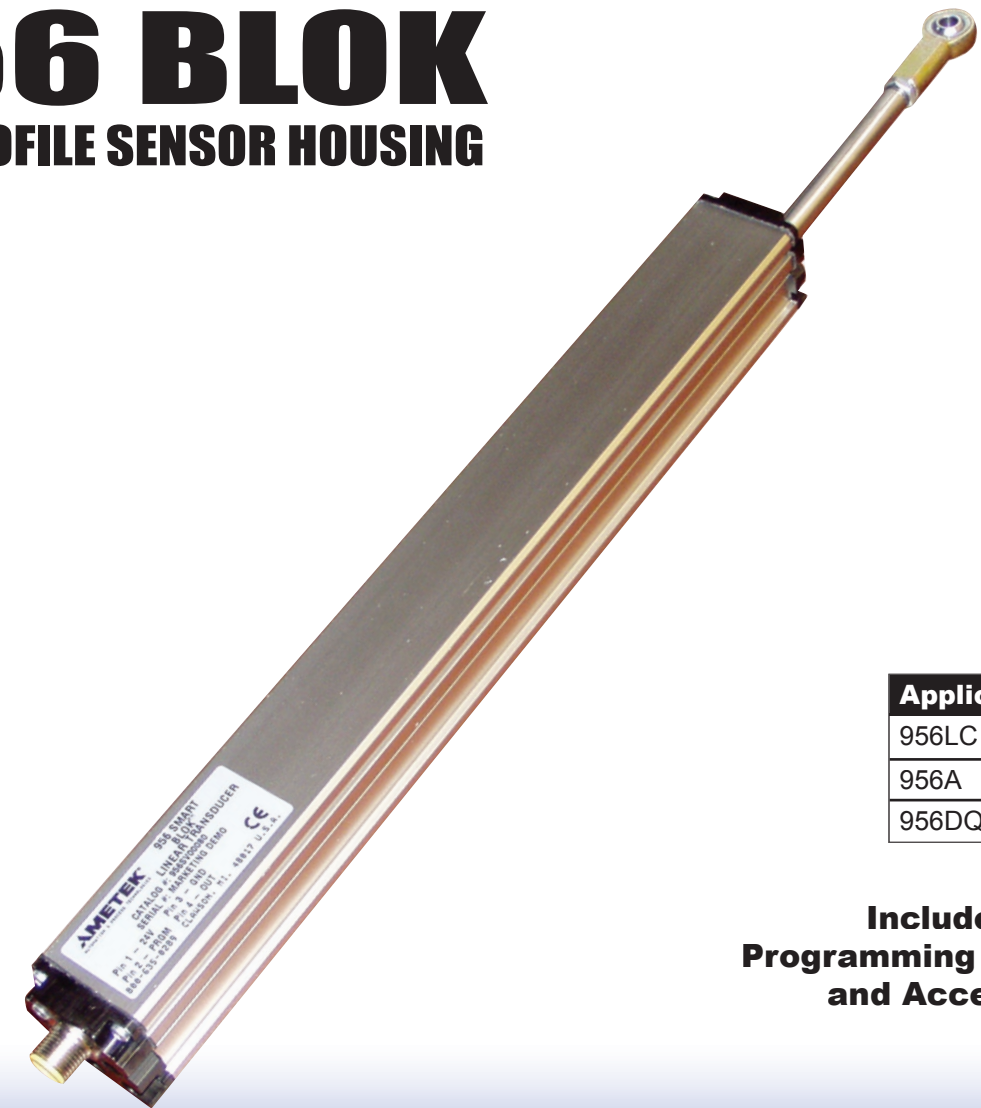

INSTALLATION MANUAL
LINEAR DISPLACEMENT TRANSDUCERS

956 BLOK
LOW PROFILE SENSOR HOUSING



Applications	
956LC	956S
956A	956D
956DQ	

**Includes 956 BLOK
 Programming Instructions
 and Accessory Guide**

**ABSOLUTE PROCESS CONTROL
 KNOW WHERE YOU ARE... REGARDLESS**

Other Products

<p>B/W Controls LIQUID LEVEL TECHNOLOGY</p>	<p>LINEAR DISPLACEMENT TRANSDUCERS PLC INTERFACE PRODUCTS ROTARY POSITION PRODUCTS PROGRAMMABLE LIMIT SWITCHES EXTREME DUTY CABLE REEL PRODUCTS ROTARY LIMIT SWITCHES RESOLVERS MILL DUTY ENCLOSURES ULTRA HIGH SPEED PLS SAFETY PRODUCTS</p>	<p>CATRAC HEAVY DUTY CABLE AND HOSE CARRIERS</p>
<p>GEMCO INDUSTRIAL BRAKES</p>	<p>Made In America</p>	

Copyright 2004 by AMETEK AUTOMATION & PROCESS TECHNOLOGIES.
 All Rights Reserved. Made in the USA. Version 1.0.



1080 N. Crooks Road, Clawson, MI 48017-1097
 Phone: 248-435-0700 Toll Free: 800-635-0289
 Fax: 248-435-8120 www.AMETEKAPT.com

956.M2R2
 4/04.Z163
 25





Preface

The **956 BLOK** is a housing option available for all 955 Brik Style Linear Displacement Transducers.

In this manual you will find all necessary dimension and mounting drawings. Wiring and programming details along with electrical specifications can be located in the 955 Installation & Programming manual.

Introduction

The Series **956 BLOK** is an exclusive two chamber industrial rod and barrel style enclosure for the Gemco 955 Series of Linear Displacement Transducers. The electronics are isolated in a chamber that has an IP67 optional IP68 rating. The piston is housed in the second chamber which has an IP65 rating. The units are available up to a stroke length of 36 inches.* The 316 stainless steel rod or piston is .375" in diameter and has 1/4"-28 threads extending from the extrusion for easy installation. The opposing end of the rod is a piston with a magnet permanently affixed that slides effortlessly through a Rulon bearing assembly. As the magnet is moved it is sensed by the electronics in the other chamber and converted to a useable output.

Accessories

Other Accessories		Compatible LDT's	
Description	Catalog Number	956A, S, LC	955D, QD
Mounting Foot (order two per probe)	SD0522000	X	X
Rod End (Shaft)	04-570256	X	X
Mount feet for .45" or .75" mounting Includes two mounting feet & spacers	SD0545100	X	X

Caution



Disconnect power before servicing.
The Gemco **956 BLOK** LDT contains no serviceable components. Consult factory for repair or replacement.

Mounting

The **956 BLOK** is available with three optional mounting heights. When using the standard SD052200 mounting feet the distance from the bottom of the foot to the center of the piston rod is .315".

When replacing linear potentiometers we offer a mounting kit which will include two standard feet and the necessary spacer to accommodate either a .45" or .75" mounting height. The part number for the spacer kit is SD0545100.

The mounting feet simply slide into the grooves on the **BLOK** extrusion and clamp down when tightened.

The **956 BLOK** comes standard with a 1/4"-28 UNC thread and a flat across the piston for attaching it to a moving member of the machine. Optional rod ends are available for ease of mounting and alignment.

When the **956 BLOK** leaves the factory it is programmed for the specific stroke length. However, the mechanical stroke of the piston is greater than the specified stroke length to help prevent damage that could occur to the unit if over-stroked.

When the piston is fully retracted, the magnet assembly will be at 3/8" (.375") into the Null Zone.

When mounting, or if you plan to re-program the unit, it is very important to stay out of this area.

To determine the usable portion of the unit, fully retract the piston assembly, then pull it out 3/8" and mark this location on the piston with either a pencil or a marker. From this point, extend the piston by the active stroke length specified in the part number on the product label. Again, mark this location on the piston.

The area between the two marks on the piston is the sensors active stroke range. To re-program the units active stroke, please refer to the programming guide located in the 955 manuals.

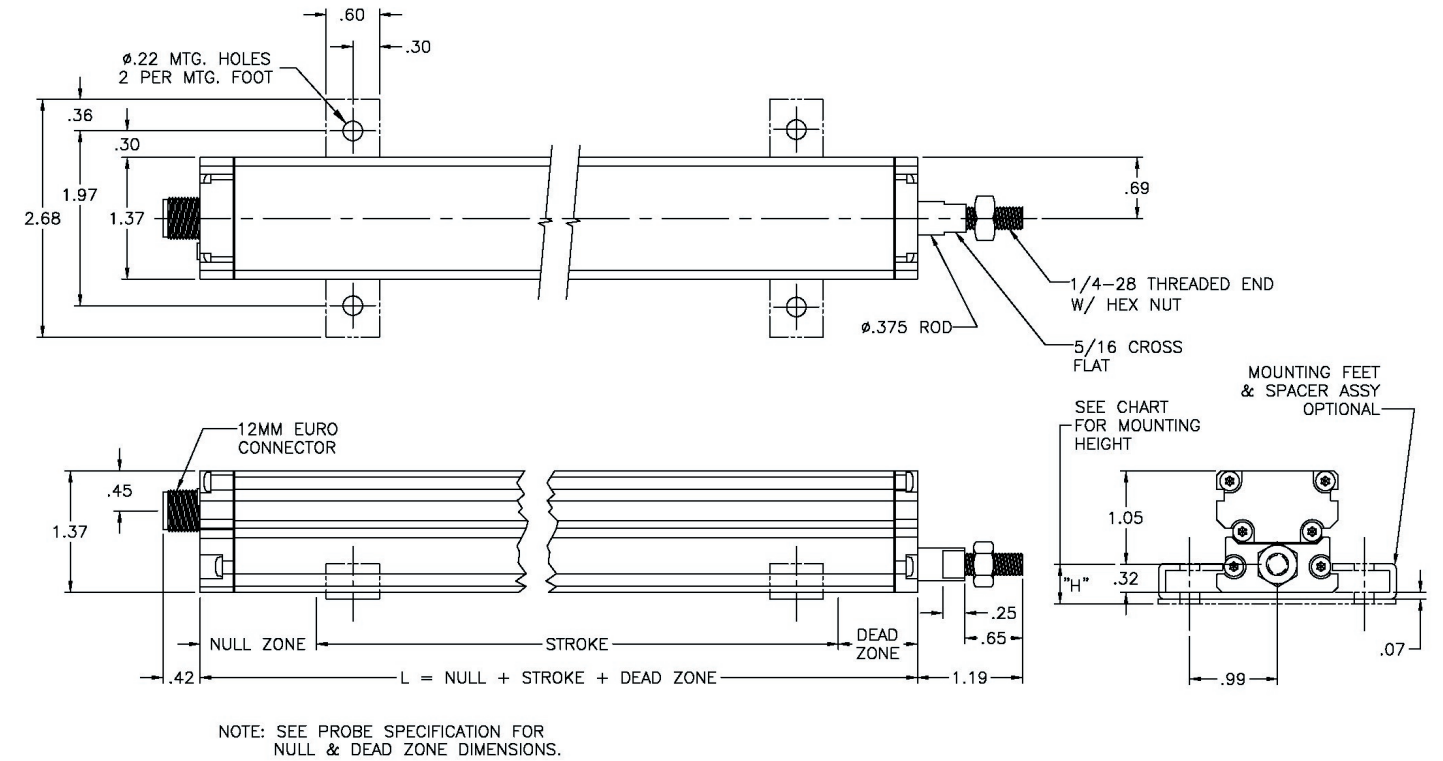

Wiring Diagram 955A Only

Euro Connector (Micro 12 mm single keyway)

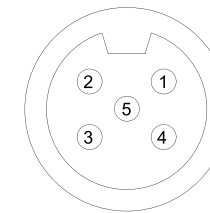

Pin #	Wire Color	Function
1	Brown	Customer Supplied Power (+VDC)
2	White	Program Input
3	Blue	Power Supply Common
4	Black	Position Output
5	Gray	Analog Output Common

Note: Refer to your specific model number and application manual for the correct wire diagram and pin location.



Optional Rod End.
Part # 04-570256

Ametek Automation & Process Technologies has checked the accuracy of this manual at the time it was approved for printing. However, this manual may not provide all possible ways of installing and maintaining the LDT. Any errors found in this manual or additional possibilities to the installation and maintenance of the LDT will be added in subsequent editions. Any comments you have for the improvement of this manual are welcomed.

AMETEK reserves the right to revise and redistribute the entire contents or selected pages of this manual. All rights to the contents of this manual are reserved by AMETEK.