

INSTALLATION AND OPERATING INSTRUCTIONS

General Description:

The 8040MD is a conductance-actuated control for detection of moisture in the oil chamber of a submersible pump motor. It is used as a warning device to indicate a seal leakage and to signal the need for preventative maintenance.

Installation:

Mount the control box vertically on a wall or other solid structure. The SERIES 8040MD is to be wired as indicated on drawing figures 1 thru 4. Terminals on the control relay are numbered and are in the same relative position as shown on the wiring diagrams. Terminals 3 and 4 must be continuously energized from an AC power source with electrical characteristics shown on the control relay data plate. Contacts 1-2, 5-6 and 9-10 are available for load duty, and if required, must be wired in series with the load device(s) and load. Terminals 7 and 8 are connected to the moisture sensing probes in the motor marked W1 and W2 via cable provided with the motor. **CAUTION: The Probe Sensing Circuit, terminals 7 and 8 have 480 volts AC. This high voltage has minimal amperage but can cause significant shocking.**

Operation:

Normally the oil surrounding the probes is non-conductive and the control will be de-energized. An influx of moisture past the outer seal and into the oil reservoir will change the conductivity of the oil and cause the relay to energize. Note that the moisture may not cause this change in conductivity until motor is running and moisture becomes emulsified with the oil. Load contacts 1-2, 5-6 and 9-10 will change from their normally open or normally closed position when the control energizes.

Test Procedure:

A normally closed pushbutton and neon indicator lamp are provided as part of the control relay for testing the moisture sensing components. The motor manufacture has provided a 330,000 Ω resistor across the probes inside the motor to complete the test. When the test pushbutton is depressed, the neon indicator lamp will be illuminated to indicate:

- A: Power is supplied to the control.
- B: The control is operative.
- C: The wiring to the moisture sensing probes in the motor is intact.

The following check does not simulate a seal leakage. Remove the enclosure cover and momentarily place a jumper wire or a 20,000 Ω resistor across terminals 7 and 8 on the control relay. This will energize the control relay and test out the neon-indicating lamp. **CAUTION: Voltage will be present at all terminals on the control relay when this test is being made.**

Catalog Numbering System

SERIES: 8040MD

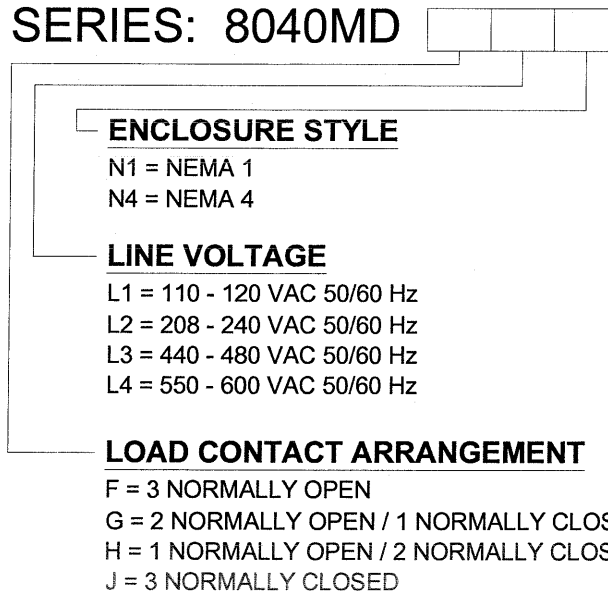

"F"
LOAD CONTACT
ARRANGEMENT
3 N.O.

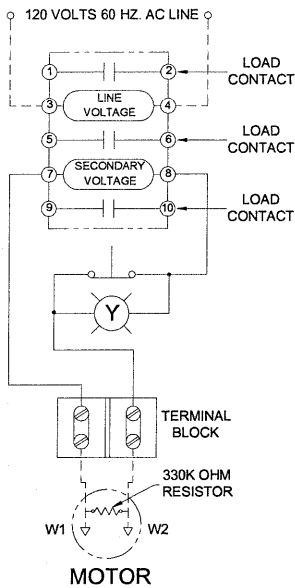

FIGURE #1

"G"
LOAD CONTACT
ARRANGEMENT
2 N.O. / 1 N.C.

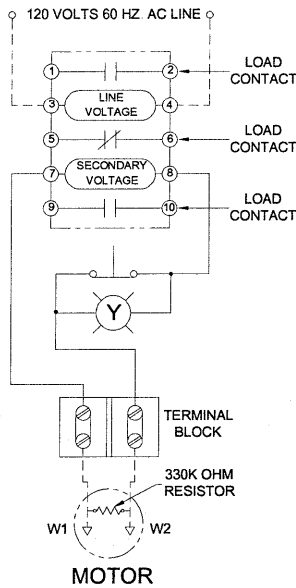

FIGURE #2

"H"
LOAD CONTACT
ARRANGEMENT
1 N.O. / 2 N.C.

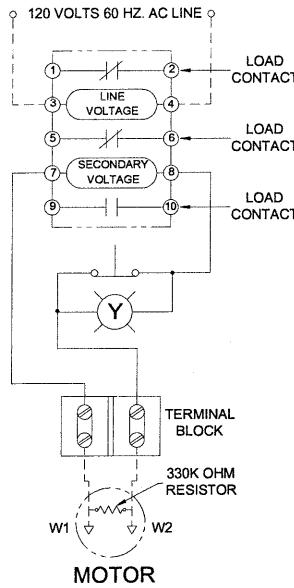

FIGURE #3

"J"
LOAD CONTACT
ARRANGEMENT
3 N.C.

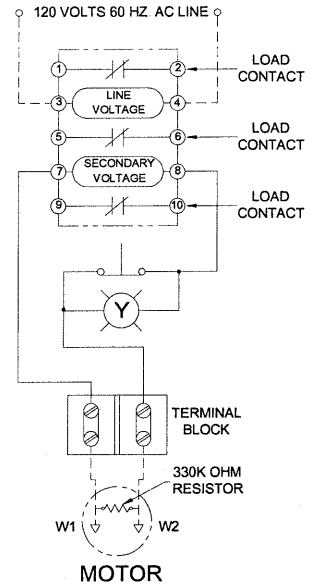
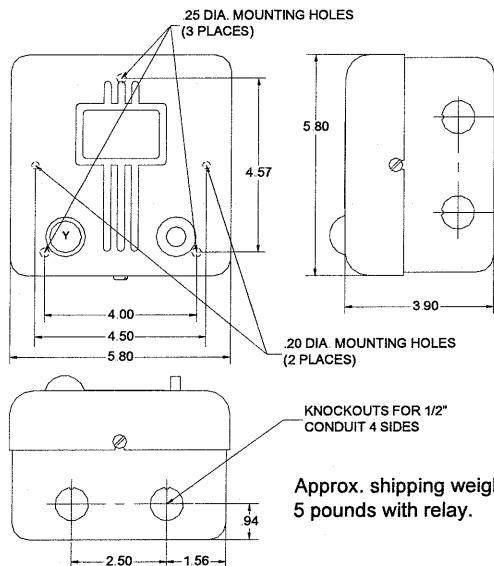

FIGURE #4

**NEMA TYPE 1
GENERAL PURPOSE ENCLOSURE**



**NEMA TYPE 4
WATER & DUST TIGHT ENCLOSURE**

