

Din Rail Mount Module Allows Standard Resolvers DeviceNet Functionality.

In many applications the harsh environment requires a rugged method of rotary positioning. Resolver technology is the proven method to obtain absolute rotary position data in the harshest environments such as steel mills, lumber and metal stamping. In areas of the plant where electronics cannot survive, but DeviceNet networks are used, we have the answer. The 1990DN mounts on a din rail in the control panel and a standard resolver is wired to the terminals. The DeviceNet network is then attached to the front connector to pass position data, RPM, and setpoint status from the module.

The 1990DN plugs in as a node on any control system with a DeviceNet Scanner Card. Continuous rotary position data is provided with 12 bit resolution. In addition, eight (8) built-in user programmable setpoints allow direct control of critical functions over the network. All programming is done over the DeviceNet network.

The Series 1990DN provides flexibility and cost savings when compared to other methods of continuous position sensing. Each resolver is wired to the module. Since every DeviceNet network is bus powered, there is no separate power supply to worry about. The 1990DN with continuous rotary position and eight (8) discrete setpoints built-in, plus a DeviceNet scanner card is competitive with a plain resolver and a PLC resolver input card. And additional resolvers can be added on the same DeviceNet network without adding additional scanner cards, making this approach very attractive when more than one resolver is needed on the same system.

Using the 1990DN, it is now possible to eliminate programmable limit switches or other added electronic modules for certain applications. This means savings on equipment and installation with improved reliability, which translates directly to improved productivity and lower costs.



Specifications	
Resolution	12 bit (4096 Counts)
RPM	1024 max.
Power Requirements	92mA @ 11 VDC Typical 67mA @ 24 VDC Typical
Inrush	350mA @ 11 VDC for 20 msec. 450mA @ 25 VDC for 10 msec.
Device Type	Generic
Communications	Group 2 slave only
Messages Supported	Polled, Bit Strobed, Explicit
Baud Rates	125K, 250K, 500K
Temperature	
Operating	-20° C to 70° C
Storage	-40° C to 85° C
Scale Factor	2 to 4096
Position Range	0 to 1 less than Scale Factor
Update Rates	
Position	915µS
RPM	29.29mS
Specifications may change without notice	

Series 1990DN DeviceNet Module Part Number

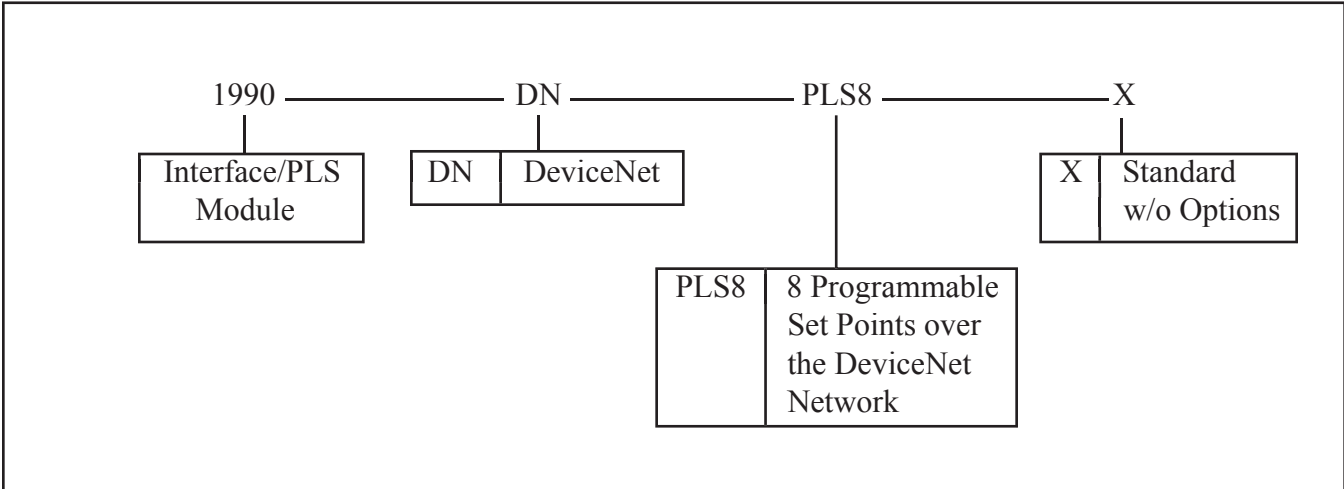

Dimensions

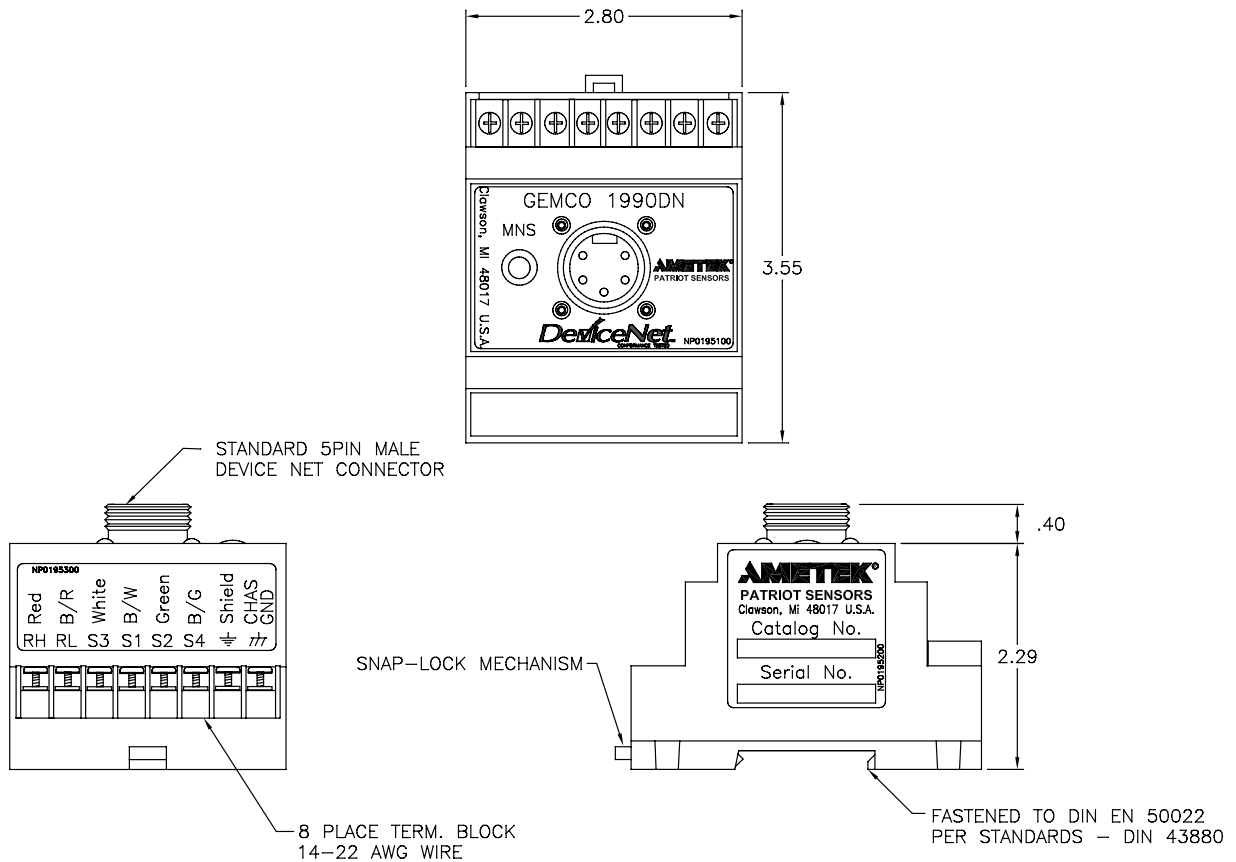

1080 N. Crooks Road • Clawson, MI 48017 • USA
 800-635-0289 • 248-435-0700 • Fax: 248-435-8120
 www.ametekapt.com • www.ametek.com

1990DN.B2R
 03/02 • Z95
 1M